

COOKING CAPACITIES

Turkeys, Hams (12-14 lb.).....	24 pieces
Pork Butt (7-8 lb.).....	48 pieces
St. Louis Ribs (2.75lb.).....	48 pieces
Baby Back Ribs (1.75 lb.).....	72 pieces
Pork Ribs (3.5 lb.).....	36 pieces
Chicken (3lb.).....	64 pieces
Brisket (10-12lb.).....	24 pieces



The SPX-300 comes standard with - Digital Thermostat/Thermometer Controller, 20" tall powder coated pipe legs, Interior Light with a Teflon Coated Safety Bulb, and Pneumatic Rotisserie Advance Foot Switch.

SPX-300 Optional Equipment - Digital Roast & Hold Control, Rib Rack, Ham Rack, Black Powder Coated Legs, Smoke Extractor, VSP Hood System.

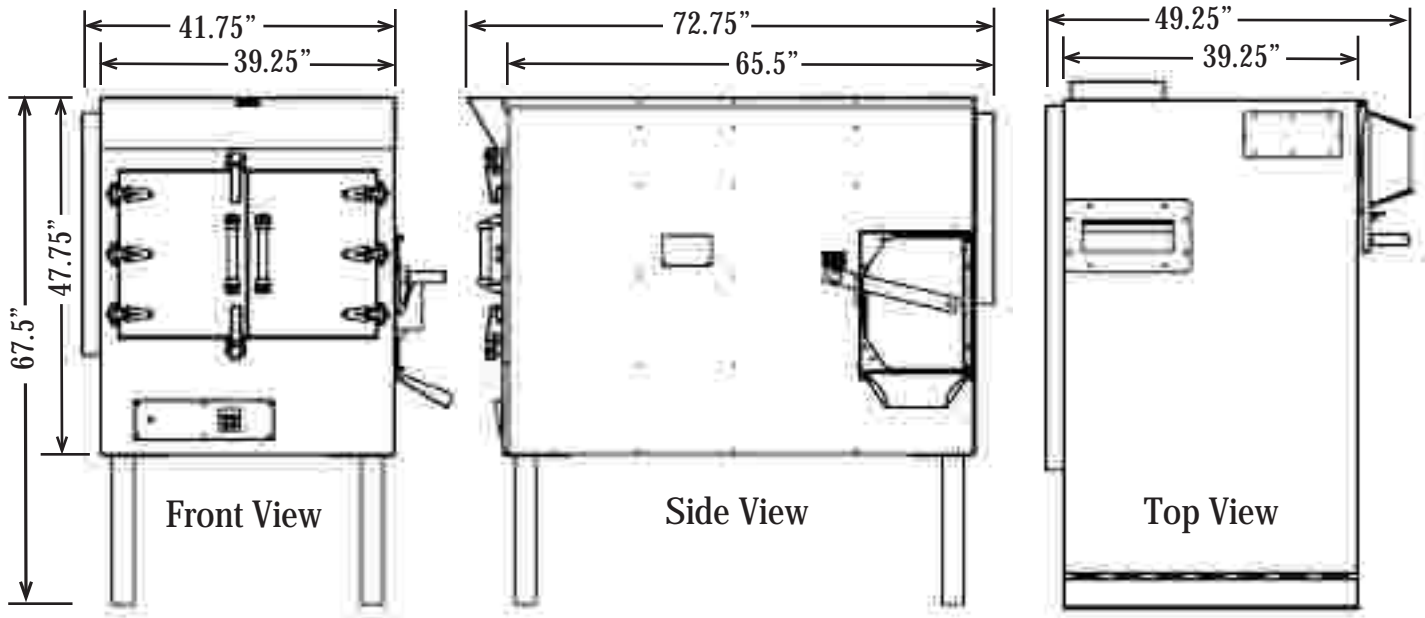

Electrical Requirements: 120 volts AC, 60 hertz, 1 phase, 15 amp wiring required.

Gas Requirements: 50,000 btu, 1/2 NPT (Located Lower Right Rear Facing Back of Oven)

Construction: Inner Liner: Combination of 20 & 14 gauge Stainless Steel.
Exterior: 20 gauge Polished Stainless Steel.

Firebox & Firebox Door: 10 ga. H.R. steel. Uses wood logs or charcoal. 2-3 logs 4-6" dia. 12-15" long.

Dimensions: 67.5" tall x 41.75" wide x 72.75" deep.

Food Racks: Rotisserie with four hanger racks, each with three - 12" x 30" food racks (12 Total). 30 Sq.Ft. of Cooking Surface. 3 1/2" spacing between food racks.

Air Circulation: Low Velocity Convection Fan.

Temperature Range: 140-325 degrees F.

Burner: Electronic Pilot Gas Burner (Specify Natural or L.P. gas.)

Shipping Weight: 1000 lbs.

Approvals: UL, ULC, Classified EPH for Sanitation with UL



VSP HOOD SYSTEM: Purchased through Southern Pride

VSP HOODS are U/L Listed to the applicable Southern Pride oven models and are NSF Certified.

HOOD SYSTEM TO INCLUDE:

1. Ventilation Hood
2. Two speed fan (1380/2000)
3. Curb with vented extension and hinge kit (Specify roof pitch)
4. Grease capture trough

SUPPLIED BY CUSTOMER:

5. Duct from hood to fan

NOTE: If you have a duct longer than 10 feet or an elbow in your duct installation, it may require a larger capacity exhaust fan. Please specify your duct requirements when ordering the VSP Hood System.

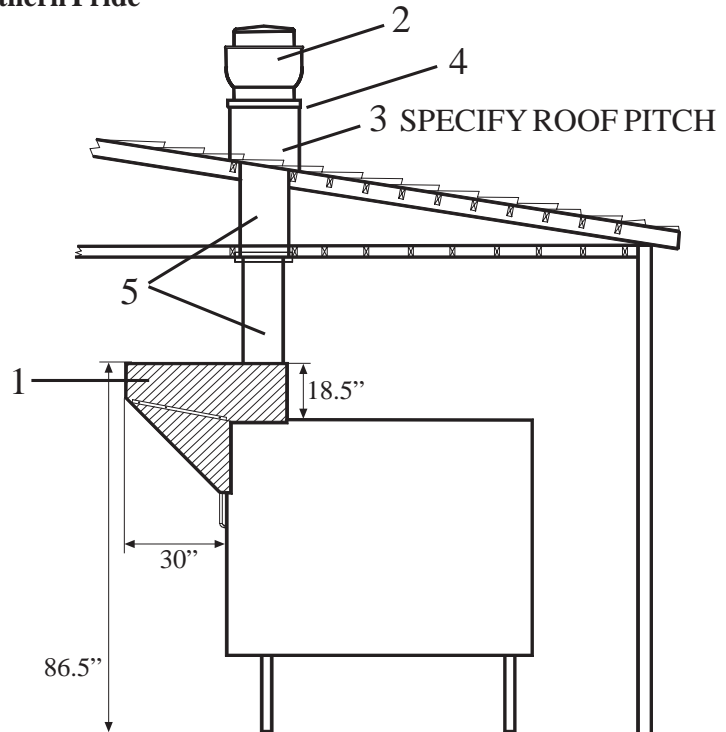

**SPX-300 with recommended
optional VSP Vent Hood System.**

The oven's minimum clearances from combustible materials are 2" on left and back side (18" clearance recommended for service access, 24" on right (access to open the firebox door), 18" on top, and 48" from front (access to open the meat doors).

ANY VENTILATION SYSTEM MUST BE INSTALLED IN ACCORDANCE WITH LOCAL CODES. CONSULT WITH LOCAL OFFICIALS AND A COMMERCIAL KITCHEN VENTILATION CONTRACTOR PRIOR TO INSTALLATION.