

**Southern
PRIDE**
WOOD BURNING BARBECUE PITS

MODEL BMJ - 1000
INSTRUCTION MANUAL

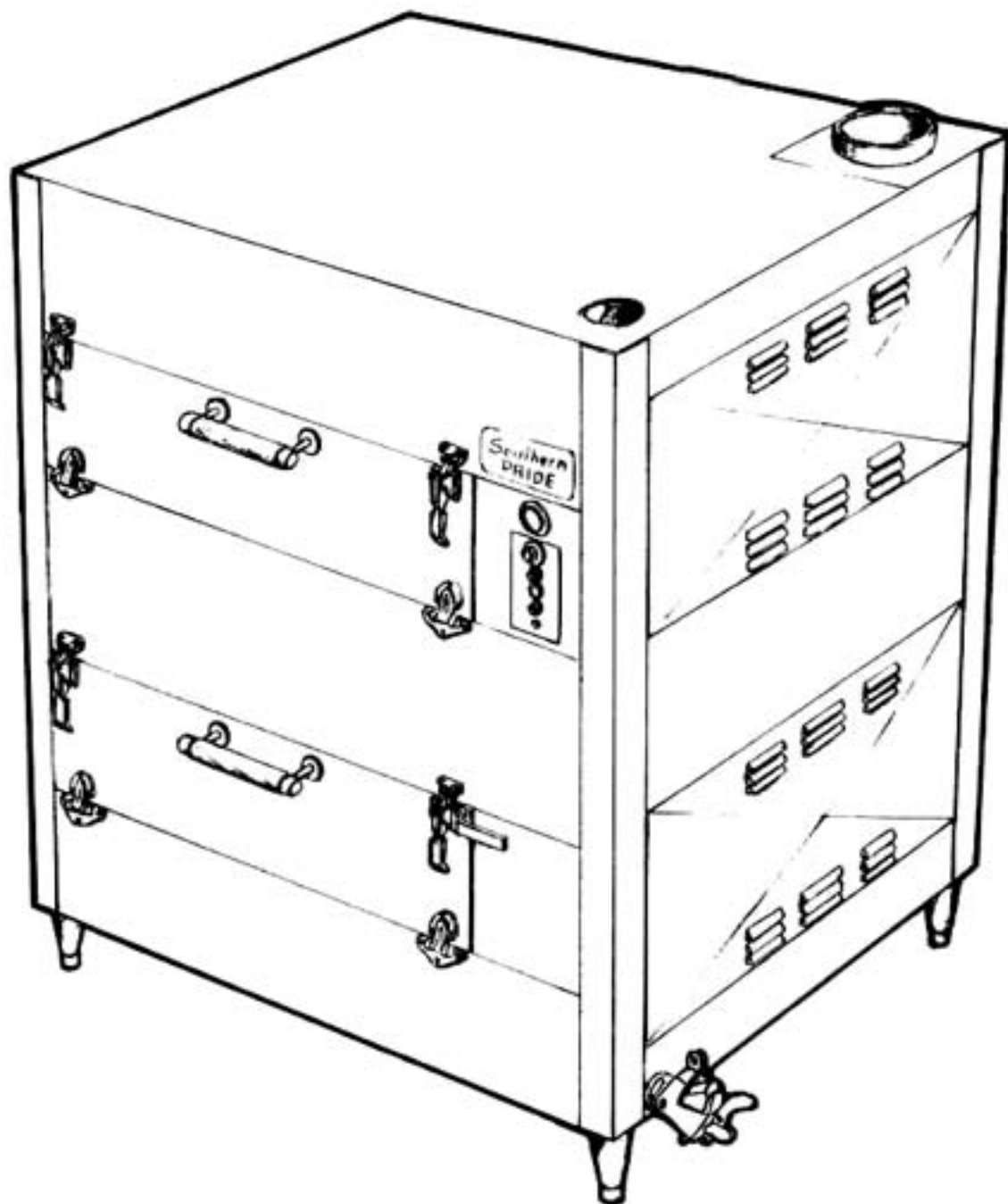

*** CONGRATULATIONS ***

In selecting **SOUTHERN PRIDE**, you have chosen the finest, most advanced, and fully automatic wood burning barbecue pit available. With us, "It's A Matter Of Pride".

Please read this **INSTRUCTION MANUAL** carefully prior to installation and operation. Proper installation, operation, cleaning, and maintenance are essential for your satisfaction and safe operation.

KEEP THIS MANUAL FOR REFERENCE

TABLE OF CONTENTS

	Page
Safety Information	1-2
Diagram of Controls & Components	3- 4
Operating Instructions	5-6-7
Cleaning Instructions	8-9
Maintenance Schedule	10-11
Installation Instructions	
Electrical	12
Burner Specifications	13
Items to Check Before Firing Burner	14
Gas Piping	15-16
Venting	17
Venting Diagram	18
Wiring Schematic	19
Wiring Diagram	19
Limited Warranty	20
Replacement Parts List	21

SAFETY INFORMATION

FOR YOUR SAFETY

IF YOU SMELL GAS

1. Open Windows.
2. Do not touch electrical switches.
3. Extinguish any open flames.
4. Immediately call your gas supplier.

DO NOT STORE OR USE GASOLINE OR OTHER FLAMMABLE VAPORS OR LIQUIDS IN THE VICINITY OF THIS OR ANY OTHER APPLIANCES.

1. The pit area **MUST** be kept clear and free of combustible materials, gasoline and other flammable vapors and liquids.
2. The flow of combustion and ventilating air **MUST NOT** be obstructed from reaching the pit.
3. The frame of the unit **MUST** be electrically grounded at all times. See "Electrical Instructions".

FAILURE TO GROUND THIS UNIT MAY RESULT IN AN ELECTRICAL SHOCK.

4. Caution should be used when opening and closing the Firebox Door. The door is **HOT** during operation.
5. **DO NOT** remove service compartment access panels when unit is in operation or leave off during operation.
6. Gas burners require the services of an experienced mechanic for proper setting and adjustment. If the burner does not appear to be operating properly, **DO NOT ATTEMPT TO ADJUST THE BURNER YOURSELF**, but call in a competent serviceman or contact B.B. Robertson Co.
7. **DO NOT** allow unqualified personnel to perform service work or adjustments on this unit. To do so, will **VOID WARRANTY** and could result in a hazardous condition.
8. Be sure any new employees, who might operate the unit, are instructed on operation and safety information prior to operating the unit.
9. Caution: Ashes removed from the Firebox should be stored in a non-combustible container with a sealed lid only. Store ashes in a well ventilated area. **FUMES COULD BE HAZARDOUS.**
10. **WARNING: IT IS EXTREMELY IMPORTANT TO FOLLOW DAILY CLEANING INSTRUCTIONS. GREASE OR SOLIDS BUILDUP INSIDE THE PIT COULD RESULT IN A FIRE HAZARD.**
11. **KEEP THIS INSTRUCTION MANUAL FOR REFERENCE.**

CAUTION

This pit is designed to operate on a controlled air intake system in order to control the combustion of the wood in the firebox.

DO NOT OPERATE PIT UNDER ANY OF THE FOLLOWING CONDITIONS:

1. **DO NOT** operate pit unless the Firebox Door and Meat Loading Door Latches are secured in the closed position.
2. **DO NOT** leave Firebox Door or Meat Loading Door open while pit is unattended.
3. **DO NOT** use aluminum foil or any other protective material on inner liner surfaces or food racks of pit.
4. **DO NOT** open Drain Valve while pit is in operation or while burning wood and hot coals are still in firebox.
5. **DO NOT** operate pit if Firebox Door or Meat Loading Door Gaskets are damaged or missing.
6. **DO NOT** operate pit unless daily cleaning procedures have been performed to remove solids buildup inside the pit.
7. **DO NOT** operate pit unless operator has been thoroughly trained on operation, safety and cleaning procedures.

WARNING

**FAILURE TO OBSERVE THESE WARNINGS COULD RESULT IN A
FIRE HAZARD**

SOUTHERN PRIDE'S BMJ - 1000

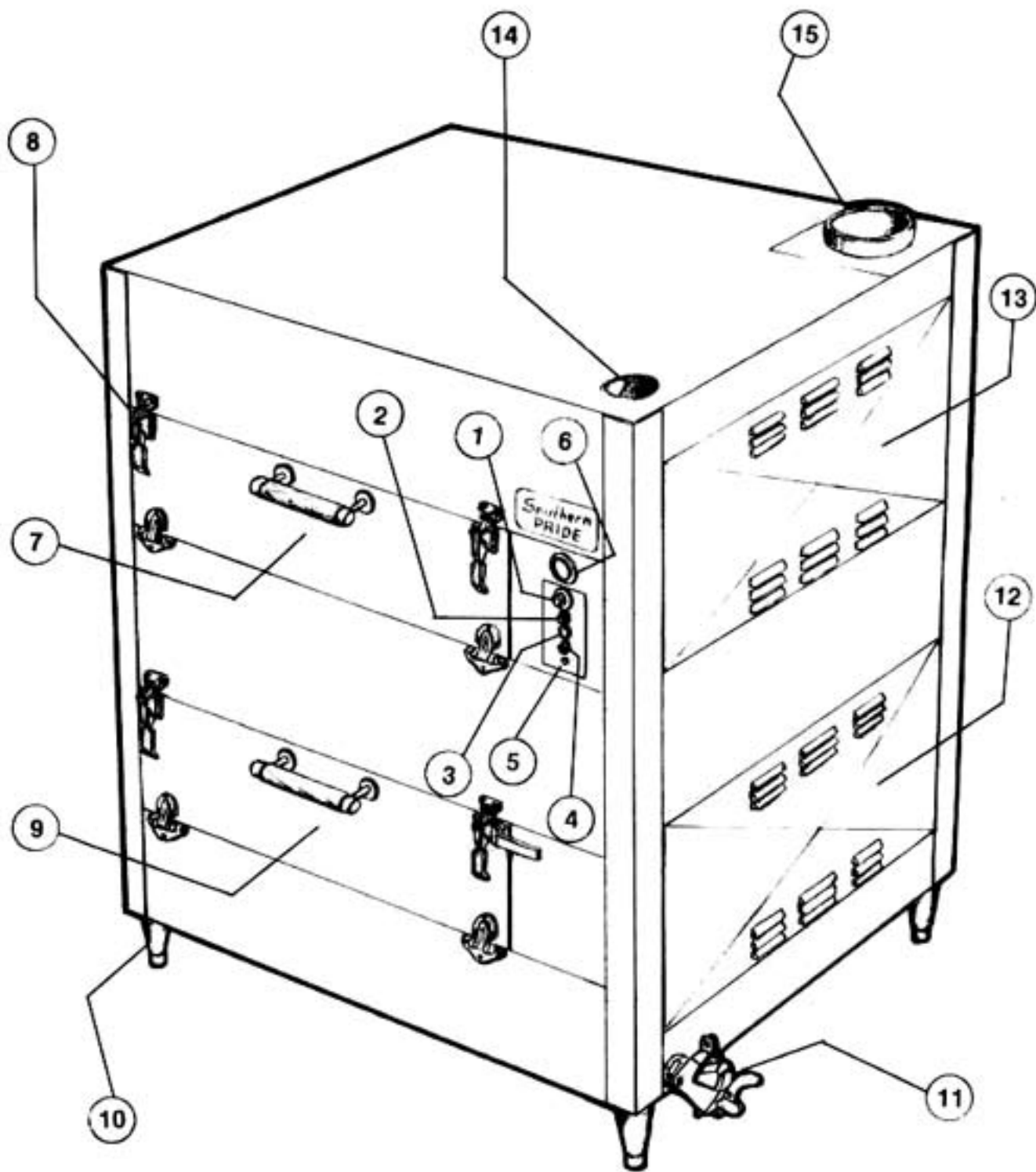

BMJ-1000 CONTROLS AND COMPONENTS

1. **CONTROL THERMOSTAT** – Adjustable temperature setting (100 - 325 Degrees F.) with OFF position. Maintains desired Pit temperature by controlling the Gas Burner.
2. **MAIN POWER SWITCH** – Activates the Rotisserie, Convection Fan, Burner, and Red Indicator Lamp. (The Red Indicator Lamp on the Main Power Switch indicates when the switch is ON.)
3. **ROTISSERIE ADVANCE SWITCH** – Momentarily activates Rotisserie to advance the food racks for loading and unloading when Meat Door is open or Main Power Switch is OFF.
4. **SMOKE EXTRACTOR SWITCH** – Activates Smoke Extractor Damper, Exhaust Fan, and Blue Indicator Lamp. (The Blue Indicator Lamp on the Smoke Extractor Switch indicates when the switch is ON.) At the same time it de-activates Burner and Red Indicator Lamp.
5. **CIRCUIT BREAKER** – Provides protection for the Rotisserie Drive Motor.
6. **DIAL THERMOMETER** – Shows at a glance the interior temperature of the pit.
7. **MEAT LOADING DOOR** – For access to Racks and Pit interior.
8. **MEAT LOADING DOOR LATCHES** – Latches apply positive pressure and seals doors.
9. **FIREBOX DOOR** – Provides access for loading of wood in the Firebox Chamber.
10. **CABINET LEGS** – Provides adjustment for leveling of the unit.
11. **DRAIN VALVE** – Is opened after each cooking to drain grease.
12. **LOWER SERVICE PANEL** – Provides access to Burner and Convection Fan.
13. **UPPER SERVICE PANEL** – Provides access to Rotisserie Drive System, Controls and Wiring.
14. **FLUE** – Collar for connection of 6" Flue.
15. **SMOKE EXTRACTOR DAMPER** – Closes to hold smoke inside pit while cooking and opens for Exhaust Fan to remove smoke when Smoke Extractor Switch is ON or when Front Doors are open.

OPERATING INSTRUCTIONS

1. Load meat on the food racks. Always load bottom rack first and distribute the weight evenly on all five sets of food racks. **DO NOT LET THE MEAT EXTEND BEYOND OR HANG OVER THE EDGE OF THE RACKS.**

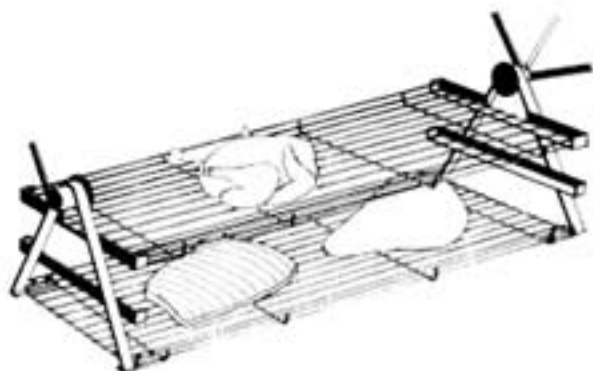

CORRECT

Load meat on bottom rack first.

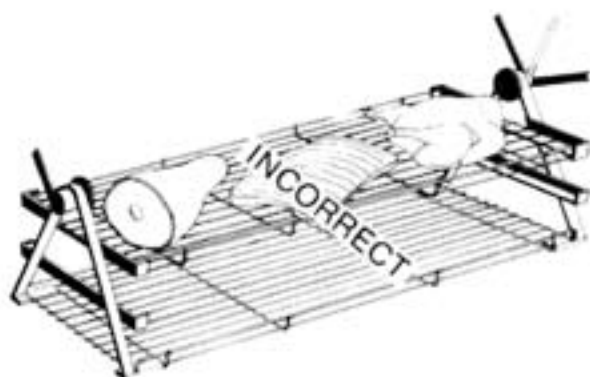

WRONG

May cause food racks to tip and meat to fall. This could cause the Rotisserie to jam.

2. To advance the racks with the Meat Door open, depress the Rotisserie Advance Switch until the racks advance to the next position.
3. After the meat is loaded, depress Rotisserie Advance Switch and allow Rotisserie to make one complete revolution. Check meat clearances to cabinet and all racks. Reposition meat on racks for maximum clearances.
4. Put a small amount of wood in Firebox. **Use 1 log, 4-6 inches in diameter, 12-15 inches long.** Use green or slightly seasoned hardwoods only.

CAUTION: DO NOT USE DRY WOOD OR KINDLING.

DO NOT OVERLOAD FIREBOX. TOO MUCH WOOD CAN CAUSE OVERHEATING OF THE PIT.

COALS AND ASHES FROM PREVIOUS COOKING MUST BE REMOVED BEFORE LOADING WOOD.

DO NOT ALLOW ASHES IN OR NEAR THE BURNER OPENING. KEEP ALL LOGS AT LEAST 6 INCHES FROM THE BURNER.

FIREBOX DOOR MUST BE CLOSED COMPLETELY BEFORE OUTER DOOR IS CLOSED.

To open Firebox Door, place Firebox Opener in bracket hole and pull straight back. **CAUTION:** Firebox is hot during operation.

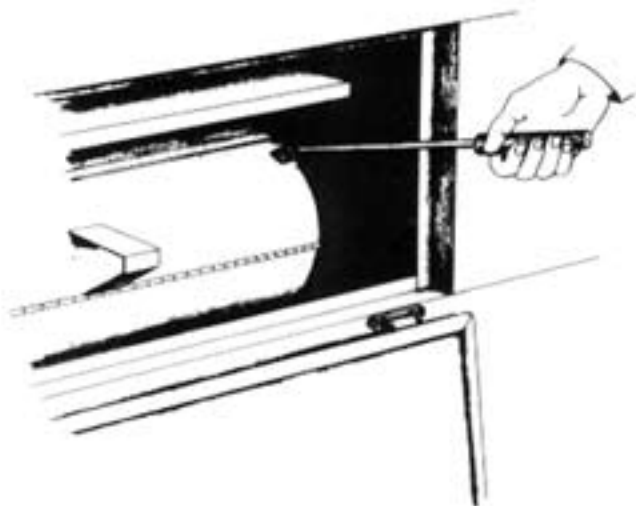

Correct way to load wood. Use one hardwood log, 4-6 inches in diameter; 12-15 inches long.



Use Ash Scoop to remove ashes and coals from Firebox.

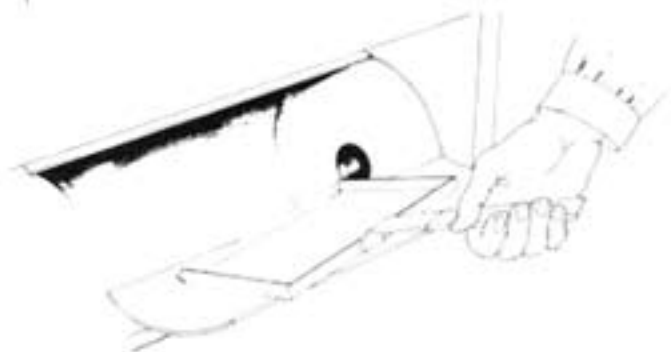

5. Be sure Firebox Door and Meat Loading Door Latches are secured in the closed position.
6. Set the Thermostat to the desired temperature setting.
7. Depress the Main Power Switch to the **ON** position. The wood will be ignited and cooking temperature will be maintained automatically. (The red lamp on the Main Power Switch indicates when the switch is **ON**.)

8. To check or unload meat, depress the Smoke Extractor Switch to the **ON** position and wait 20 seconds prior to opening the Meat Loading or Firebox Doors. (The blue lamp on the Smoke Extractor Switch indicates when the switch is **ON**.)

NOTE: Smoke Extractor will come **ON** automatically when the Meat Loading Door or Firebox Door is opened. However, we recommend that the above procedure be followed to eliminate smoke from exiting the doors when it is first opened.

CAUTION: DO NOT LEAVE SMOKE EXTRACTOR SWITCH ON DURING THE COOKING PROCESS.

9. When the meat is cooked, depress the Main Power Switch to the **OFF** position. Before opening Meat Door, depress the Smoke Extractor Switch to the **ON** position and wait 20 seconds. To unload racks, depress the Rotisserie Advance Switch until the racks advance to an unloading position.
10. After each cooking, remove the remaining wood and hot coals from Firebox, then open Drain Valve and drain grease from the Grease Pan while the pit is still warm.

CAUTION: BE SURE MEAT LOADING DOOR AND FIREBOX DOOR ARE SECURED IN THE CLOSED POSITION IMMEDIATELY FOLLOWING A COOKING AND DURING NON-USE PERIODS.

WARNING: DO NOT OPEN DRAIN VALVE WHILE PIT IS IN OPERATION OR WHILE BURNING WOOD AND HOT COALS ARE STILL IN FIREBOX.



IMPORTANT

The Gas Burner is equipped with an automatic ignition system. To ignite, depress the Main Power Switch to the **ON** position and set Thermostat to desired temperature. To shut Burner **OFF**, depress the Main Power Switch to the **OFF** position.

CLEANING INSTRUCTIONS

1. Remove ashes and coals from Firebox after each cooking.

Ash Disposal: Ashes should be placed in a non-combustible container with a tight fitting lid. The closed container of ashes should be placed on a non-combustible floor well away from all combustible material, pending final disposal.

Use Ash Scoop to remove ashes and coals from Firebox.

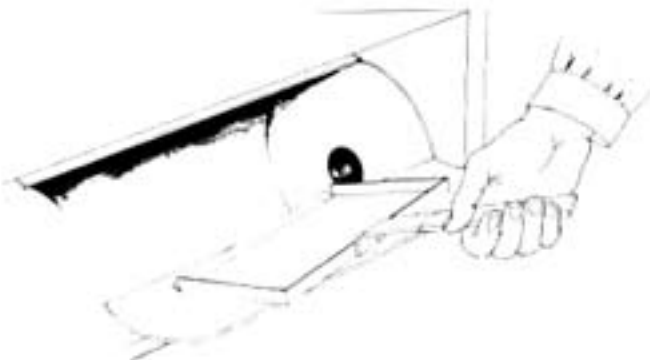

Place ashes and coals in a non-combustible container with a tight fitting lid.

CAUTION: Fumes could be hazardous.

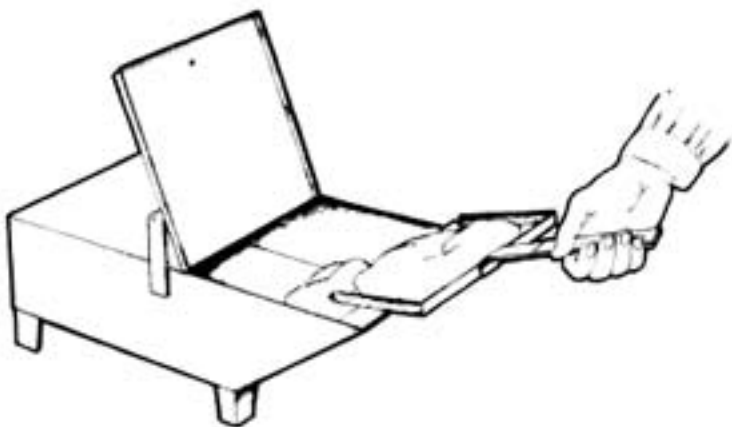

2. Drain grease. (Be sure hot coals and wood are removed from the Firebox before opening Drain Valve.)

Open Drain Valve and drain Grease Pan.



3. Remove food racks and clean thoroughly.

To remove food racks, lift left hanger and pull straight back over Rotisserie Wheel Stub. Lift right hanger and move to the left over Rotisserie Wheel Stub and washer. (Top racks simply lift out of the brackets on the hangers.)

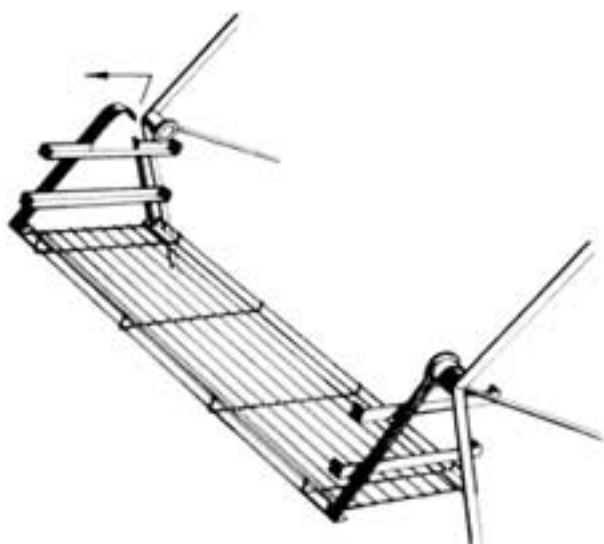

4. Thoroughly clean complete interior of pit. Use food service degreaser. Spray degreaser on the interior of the pit and allow to set for 5-10 minutes. Rinse thoroughly with water hose or pressure washer. Drain through Drain Valve.

Use Drain Pan with hose to aid in the draining of the degreaser and rinse water **while** cleaning.



WARNING

IT IS EXTREMELY IMPORTANT TO FOLLOW THE ABOVE **DAILY** CLEANING PROCEDURES. GREASE OR SOLIDS BUILDUP INSIDE THE PIT COULD RESULT IN A **FIRE HAZARD**.

MAINTENANCE SCHEDULE

WEEKLY

1. Grease Rotisserie Shaft Bearing on the left wall inside the pit.
With a hand grease gun, put 3 full pumps into bearing.

CAUTION: Do not overfill bearing with grease. This could cause damage to the seals and reduce the lifetime of the bearing.

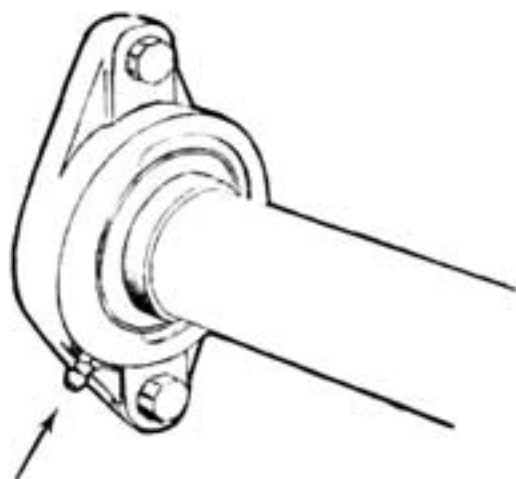

2. Grease hubs on Rotisserie Wheels.



NOTE: (Items 1 & 2) Use Dubois FGG Extra High Temperature Food Machinery Grease with USDA "AA" Rating for incidental food contact or equivalent.

3. Inspect Burner Head for accumulation of ashes and creosote. Clean as needed.
4. Inspect Convection Fan Blade for solids buildup or out of balance condition. Clean or replace as needed.
5. Inspect Meat Loading and Firebox Door Gaskets. Replace if damaged or leaking.
6. Inspect Smoke Extractor Louver to be sure it closes completely. Clean or repair as needed.
7. Inspect the Interlock Switches to be sure the Plunger and Roller move freely. Lubricate with WD-40 or equivalent as needed.

BI-MONTHLY INTERVALS

1. The Chimney Connector and Chimney should be inspected at least twice monthly to determine if creosote buildup has occurred.

Creosote – Formation and need for removal:

When wood is burned slowly, it produces tar and other organic vapors, which combine with expelled moisture to form creosote. The creosote vapors condense in the relatively cool chimney flue of a slow burning fire. As a result, creosote residue accumulates on the flue lining. When ignited, this creosote makes an extremely hot fire.

IF CREOSOTE HAS ACCUMULATED IT SHOULD BE REMOVED TO REDUCE THE RISK OF A CHIMNEY FIRE.

1 MONTH INTERVAL

1. Grease Drive Bearing on Gearbox. Fitting is located on right side of the Gearbox directly under the Rotisserie Motor. With a hand grease gun, put two full pumps into bearing. **DO NOT OVERFILL.**

NOTE: Use Dubois FGG Extra High Temperature Food Machinery Grease or equivalent.

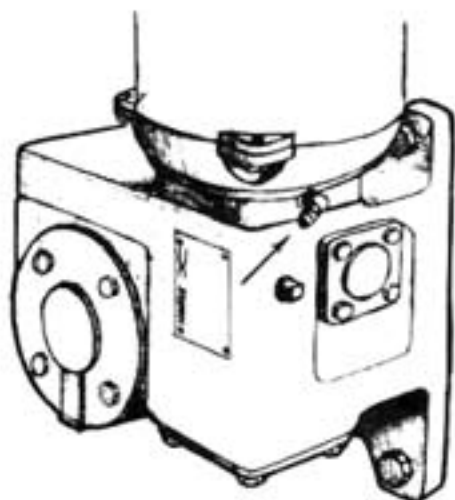

3 MONTH INTERVAL

1. Check the oil level in the Gearbox. To check, remove the Level Plug located on the left side of the Gearbox and see if the oil level is up to this point. If no oil is visible, add oil until overflow occurs.

NOTE: Use Mobil Synthetic Gear Oil SHC 634 or equivalent.

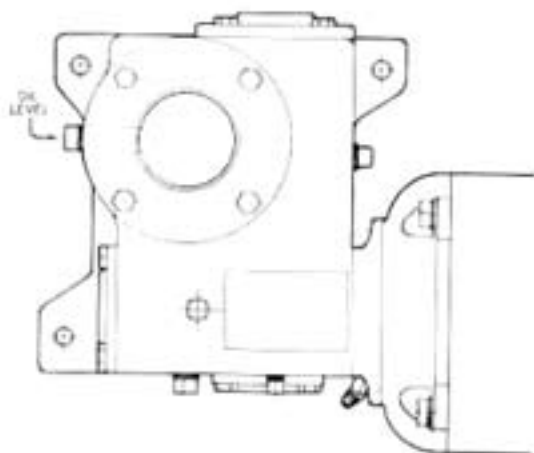

2. The Flue Pipe should be carefully inspected. Remove any solids buildup that has accumulated.

ELECTRICAL INSTRUCTIONS

ELECTRICAL REQUIREMENTS:

120 volts A.C., 60 hz.,
2 wire, single phase,
15 amp wiring required.

WARNING:

CHASSIS MUST BE GROUNDED TO PREVENT POSSIBLE SHOCK HAZARD. DO NOT ASSUME A PLUMBING LINE WILL PROVIDE SUCH A GROUND.

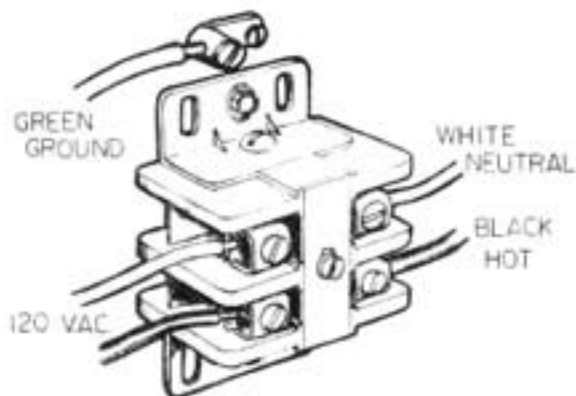

WARRANTY IS VOID IF UNIT IS CONNECTED TO ANY VOLTAGE OTHER THAN SPECIFIED ABOVE AND ON NAMEPLATE.

1. Electrician must provide the conduit and wire for hookup.
2. Power is to be left **OFF** throughout installation.
3. Electrical service is connected to the Terminal Block at the lower right rear of the unit. Remove Lower Service Door via two screws for access. A 7/8 inch diameter hole is provided in the back panel for conduit connection.
4. After connecting electrical service as specified, test the voltage on the field wired side of the Terminal Block with a voltmeter. Should be 120 volts A.C.
5. Electrician must provide conduit and wire for hookup from Junction Box above the Smoke Extractor Motor in the top of the Service Compartment to the Exhaust Fan. Make electrical connections inside the Junction Box.

NOTE: 125 V.A.C., 1/2 hp maximum connected load, 1100 cfm fan rating recommended.

6. Replace the Service Doors via four screws. If venting and gas connections have been made, the pit is now ready for "Operating Instructions." If venting or gas connections are to be done later, be sure that power is **OFF**.

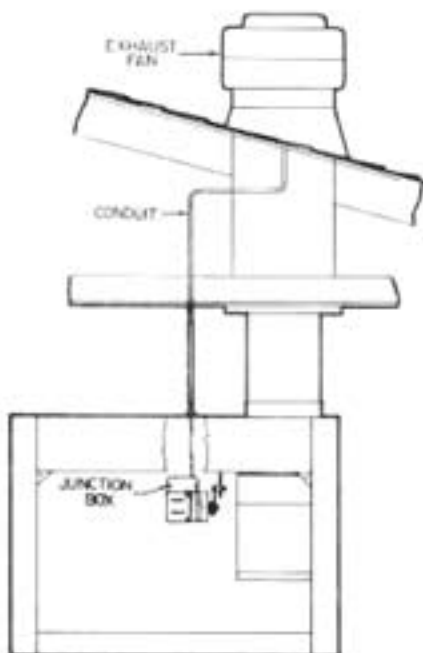

BURNER SPECIFICATIONS

Burner Model: Wayne P250AF-DI

Firing Capacity: Maximum Input 75,000 BTU/HR

Fuels: Natural and L.P. Gases

Electrical: 120 V.A.C., 60 hz, 1 ph

Orifice Sizes: Natural Gas - 5/32 (.156)

L.P. Gas - #41 (.096)

NOTE: Orifice and valve setting must correlate with type of gas being supplied.

Gas Supply Line Pressure: Natural - 4.5" W.C. Minimum
10.5" W.C. Maximum

L.P. - 11.0" W.C. Minimum
13.0" W.C. Maximum

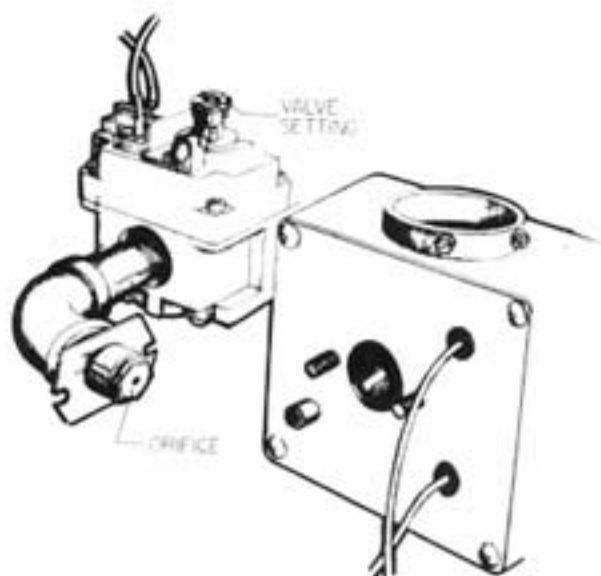
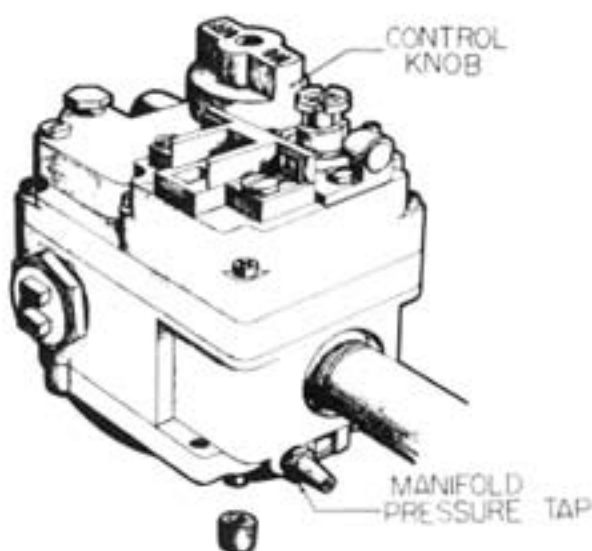

Manifold Pressure: Natural - 3.5" W.C.
L.P. - 10.0" W.C.

Gas Valve: Control Knob **MUST** be ON.

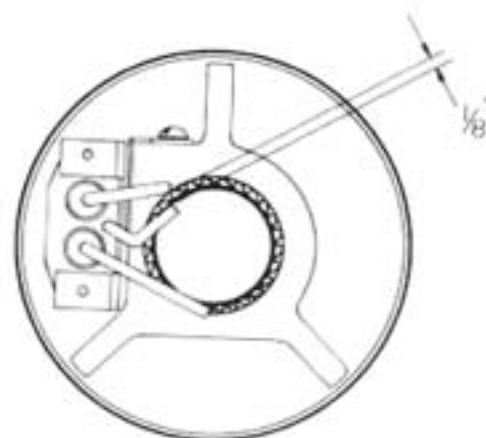
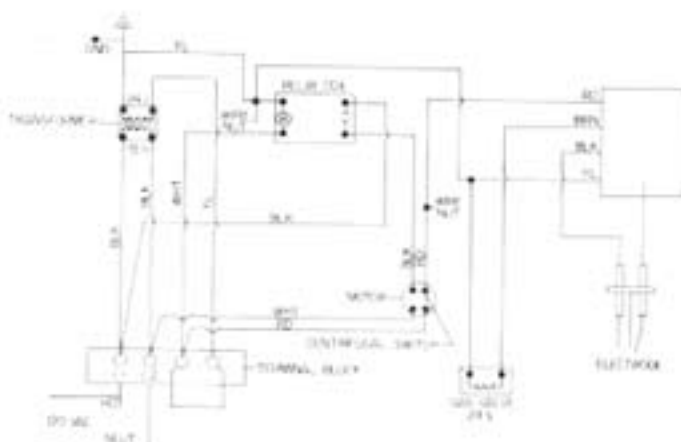

PROPER ELECTRODE LOCATION

ITEMS TO CHECK BEFORE FIRING BURNER

IMPORTANT

WARNING: IMPROPER GAS HOOKUP WILL VOID WARRANTY AND COULD RESULT IN A HAZARDOUS CONDITION.

1. Gas line **MUST** be installed by a competent technician and in accordance with this Manual.
2. Gas line **MUST** include an easily accessible manual shutoff valve, drip leg, and pressure gauge port.
3. Gas pipe size **MUST** be in accordance with the Pipe Capacity Chart in this Manual.
4. Gas line **MUST** be tested for leaks under pressure.
5. Gas Line **MUST** be purged to remove any air in the system.
6. Gas line pressure **MUST** be checked and **MUST NOT** exceed the maximum pressure specified in the Burner Specifications in this Manual.
7. Burner Orifice **MUST** correlate with the type of gas being supplied, as specified in the Burner Specifications in this Manual.

GAS PIPING INSTRUCTIONS

1. READ ALL GAS PIPING INSTRUCTIONS CAREFULLY BEFORE MAKING GAS CONNECTIONS.

WARNING: IMPROPER GAS HOOKUP WILL VOID WARRANTY AND COULD RESULT IN A HAZARDOUS CONDITION.

2. Connect the gas line to the 1/2 inch piping that extends from the Gas Burner, through the back right panel of the unit. A 1/2 inch N.P.T. fitting is required.

NOTE: All piping must comply with local codes and ordinances of the National Fuel Gas Code ANSI Z 223.1-1974 and NFPA #54.

3. A sediment trap or drip leg must be installed in the supply line to the Burner.
4. A union shall be installed in the gas line adjacent to and upstream from the Control Manifold and downstream from the manual main shutoff valve.

Location of Union and Drip Leg.

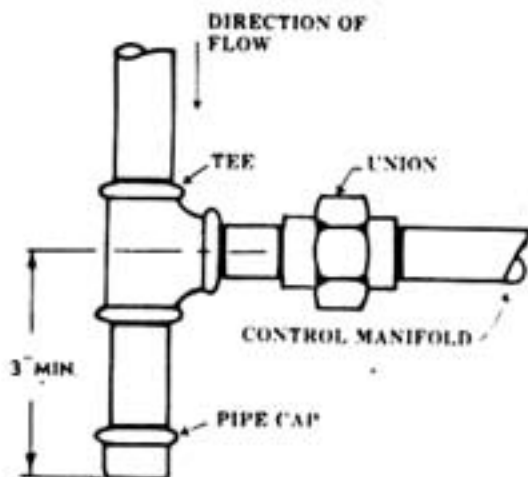

5. A 1/8 inch N.P.T. plugged tapping accessible for test gauge connection shall be installed immediately upstream of the gas supply connection for the purpose of determining the gas supply pressure to the Burner.

6. A manual shutoff valve shall be installed in the gas supply line external to the unit.

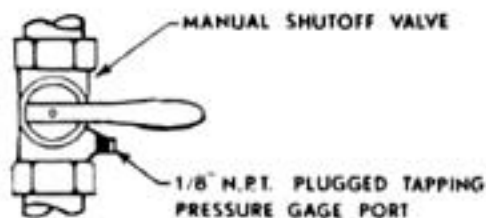

7. The gas line should be a separate supply direct from the meter to the Burner. It is recommended that a new pipe be used and located so that a minimum amount of work will be required in future servicing. The piping should be so installed as to be durable, substantial, and gas tight. It should be free from cutting burrs and defects in structure and threading. Cast iron fittings or aluminum tubing should not be used for the main gas circuit. Joint compounds (pipe dope) should be used sparingly on male threads only and be approved for all gases.

NOTE: The building structure should not be weakened by installation of the gas piping. The piping should not be supported by other piping, but should be firmly supported by pipe hooks, straps, bands, or hangers. Butt or lap welded pipe should not be bent.

8. The Pipe Capacity Chart must be used to determine the size pipe to use from the meter to the Burner.

PIPE CAPACITY CHART

PIPE SIZE	MAXIMUM LENGTH FT.	
	NAT.	LP.
3/8	—	10
1/2	10	30
3/4	70	150
1	200	250
1 1/4	250	—

FOR GAS PRESSURES OF 0.5 PSIG OR LESS BASED ON A 0.60 AND 1.50 SPECIFIC GRAVITY GAS.

9. **TEST PIPING FOR LEAKS.** Before turning gas under pressure into piping, all openings from which gas can escape must be closed. Immediately after turning on gas, the system should be checked for leaks. This can be done by watching the ½ cubic foot test dial for 5 minutes to show any movement, or by soaping each pipe connection and watching for bubbles. If a leak is found, make the necessary repairs and repeat the above test.

NOTE: Defective pipes or fittings should be replaced and not repaired. Never use a flame or fire of any form to locate gas leaks, use a soap solution.

10. After the piping and meter have been checked completely, **PURGE THE SYSTEM OF AIR.** Do not bleed the air inside the unit. Be sure to relight all the gas pilots on other appliances.

NOTE: The Burner and its individual shutoff valve must be disconnected from the gas supply piping system during any pressure testing at excess of ½ psig.

VENTING INSTRUCTIONS

1. Unit must be level for proper grease drainage.
2. If the unit is to be installed in a sealed room or building utilizing exhaust fans, it is recommended that the unit be supplied with a return air system to eliminate negative air pressure in the room or building. Return air must be equal to or in excess of the exhausted air.

CAUTION: Negative air pressure will cause smoke to exit from the Draft Diverter into the room.

3. Unit **MUST** be vented in accordance with the National Fire Protection Association (NFPA) Standard for Chimneys, Fireplaces and Vents, NFPA No. 211, which requires connections of the oven to a chimney for a residential type or building heating appliances.

NOTE: It is recommended that a local contractor be consulted regarding codes covering wood burning and gas operated appliances before installation.

4. Minimum spacings to combustible materials:

Back – 2"

Right Side – 18" (access for service)

Left Side – 2"

Top – 18"

Front – 48" (Access for loading and unloading)

Chimney Connector – 18"

Smoke Extractor Chimney Connector – 18"

Floor – May be combustible material.

NOTE: For flush mount, use BBR Insulation Kit #2097.

VENTING DIAGRAM

NOTE: NFPA Standards require that the chimney extend at least 3 feet above the highest side of the roof opening and be at least 2 feet higher than any portion of the building within 10 feet horizontal.

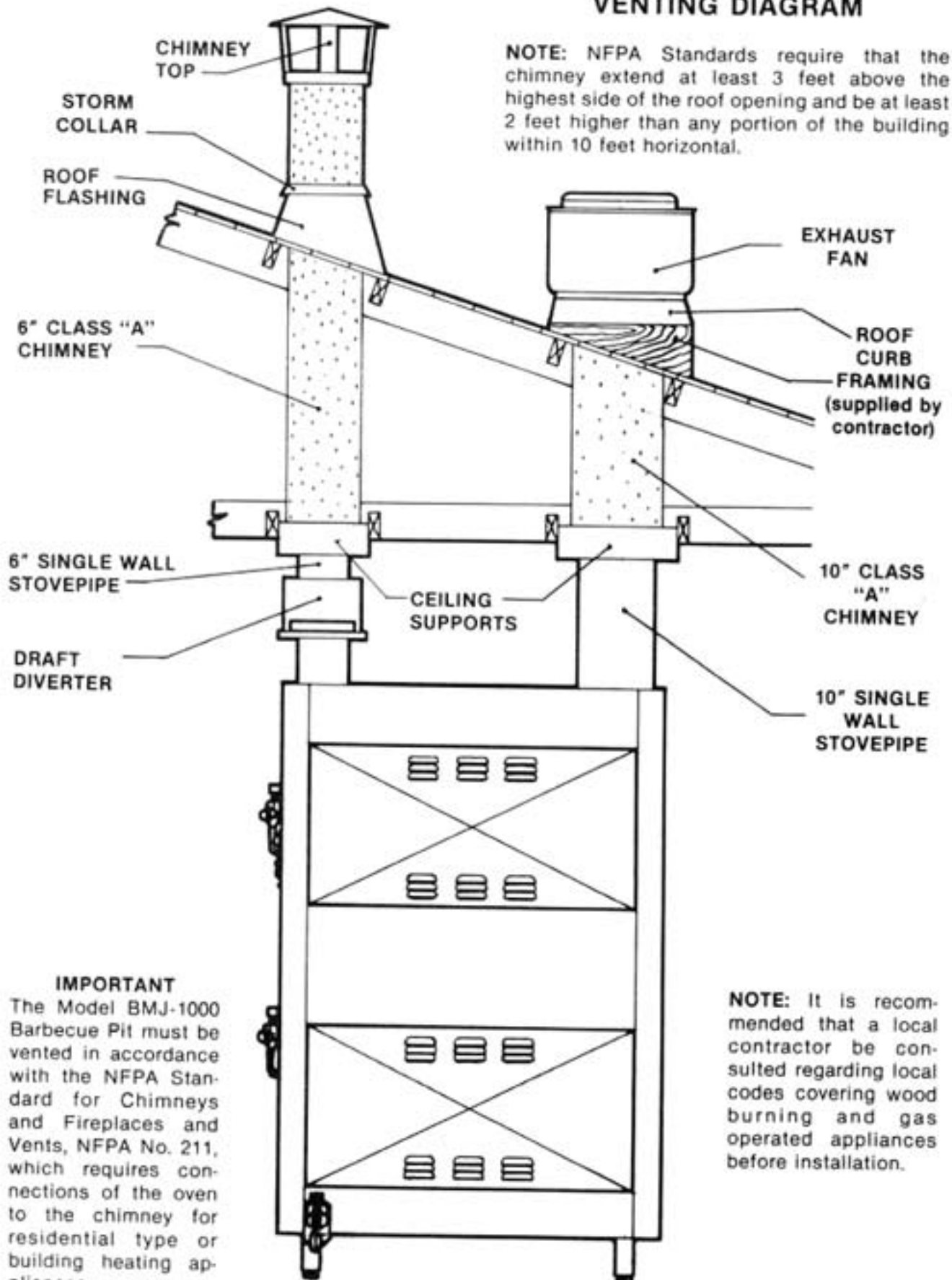

IMPORTANT

The Model BMJ-1000 Barbecue Pit must be vented in accordance with the NFPA Standard for Chimneys and Fireplaces and Vents, NFPA No. 211, which requires connections of the oven to the chimney for residential type or building heating appliances.

NOTE: It is recommended that a local contractor be consulted regarding local codes covering wood burning and gas operated appliances before installation.

BMJ-1000 WIRING

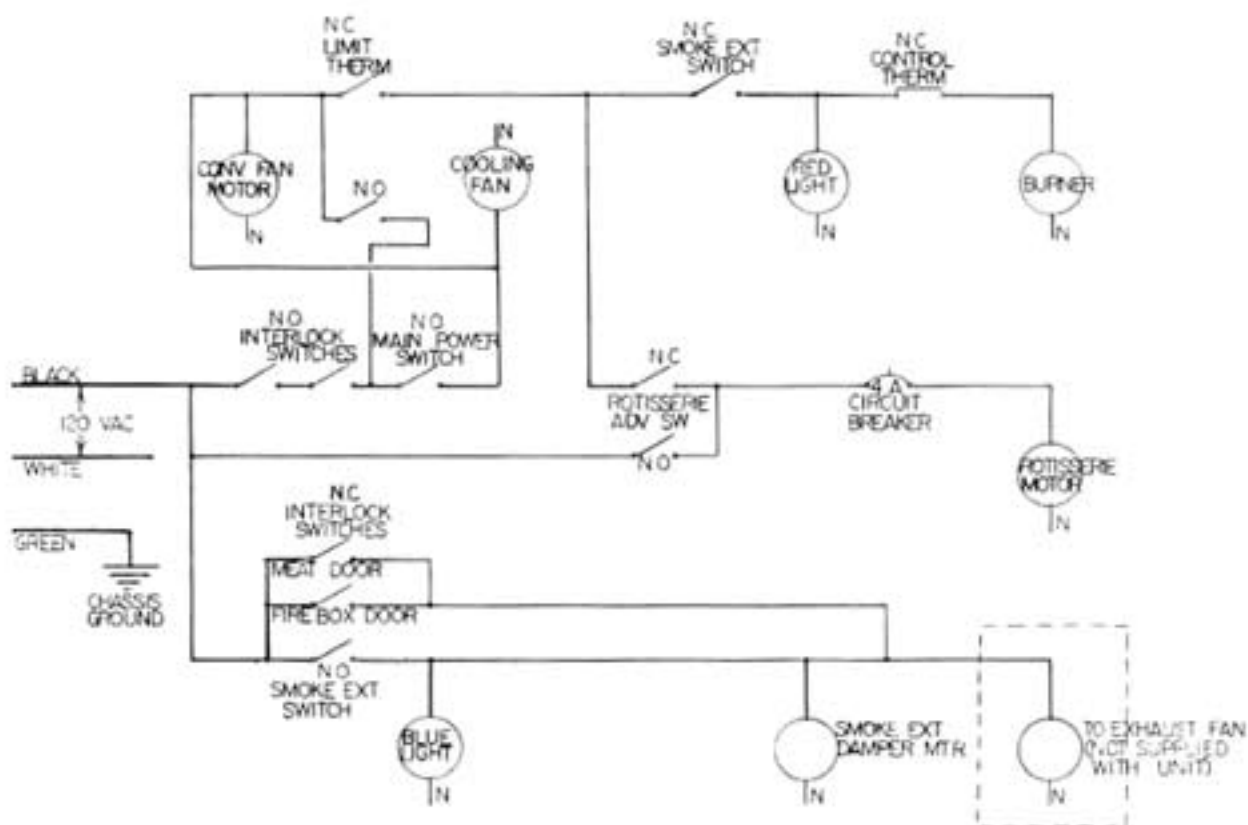

WIRING SCHEMATIC

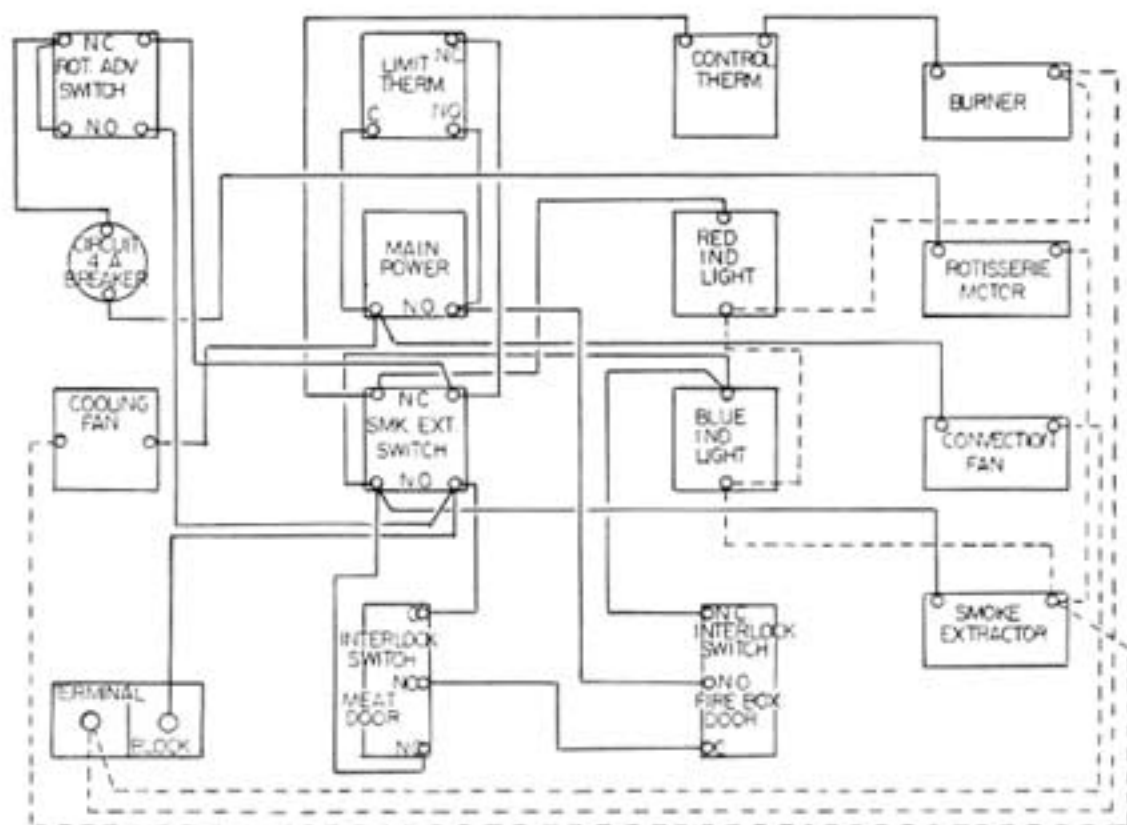

WIRING DIAGRAM

LIMITED WARRANTY

The B. B. Robertson Company, subject to the terms and conditions set forth below, warrants to the original user that:

1. Its products and the component parts thereof are free from defects in material and workmanship for a period of one year from the date of purchase.
2. If any product or component parts thereof prove to be defective, B. B. Robertson Company will either repair or replace such product, at its option, provided the defective product or component part is returned to B.B. Robertson Company with proof of date of purchase, transportation charges prepaid, within one month of the discovery of the defect and B. B. Robertson Company's examination discloses to its satisfaction that the product or component part was defective.
3. Except to the extent prohibited by applicable law, the limited warranty set forth herein shall be the exclusive warranty made by B. B. Robertson Company and in lieu of all other warranties, express or implied (whether written or oral), except the implied warranties, which include, but are not limited to, the implied warranties of merchantability and fitness for a particular purpose and which are limited to the duration of this limited warranty, and B. B. Robertson Company shall not be liable for any incidental, consequential, special or contingent damages or expenses arising, directly or indirectly, from any defect in the product or from the use thereof. The remedy set forth herein shall be the exclusive remedy available to any user of the product and in lieu of all other remedies. B. B. Robertson Company neither assumes nor authorizes any representative or other person to assume for it any obligation or liability other than expressly set forth herein.
4. This warranty does not cover damage caused by accident, abuse, misuse, unauthorized alteration or repair, failure to provide normal maintenance or operation contrary to B. B. Robertson Company's operating instructions.
5. No charge for labor, freight or other expenses incurred in the repair, removal or replacement of any product or component part thereof sold by B. B. Robertson Company claimed to be defective will be paid by B. B. Robertson Company to any user of the product, and B. B. Robertson Company shall not be liable for any expenses incurred by any user of such a product to remedy any defect in the product or component parts thereof without the expressed written consent of an officer of the company.
6. Since B. B. Robertson Company has no direct control over any phase of actual installation or changes in plans or specifications, full responsibility for field installation shall rest with the installer.
7. In order to submit a warranty claim, call or send a letter describing the defective product to:

Warranty Claims Manager
B. B. Robertson Company
Route 2 - Box 21A
Marion, Illinois 62959

8. B. B. Robertson Company assumes no liability on parts replaced or repaired without its consent. Replacement parts and repaired parts will be shipped to the original user freight collect.

B. B. ROBERTSON CO. • ROUTE 2 • BOX 21A • MARION, IL 62959 • (618) 997-9348

MODEL BMJ-1000 REPLACEMENT PARTS LIST

PARTS NUMBER	DESCRIPTION
1080	Red Main Power Switch
1082	Green Rotisserie Advance Switch
1081	Blue Smoke Extractor Switch
1068	4 amp Circuit Breaker
1003	Control Thermostat
1038	Limit Thermostat
1005	Interlock Switch
2435	Dial Thermometer
1078	Rotisserie Motor (1/8 hp)
2431	Rotisserie Gearbox
1060	Smoke Extractor Motor
1039	Compartment Cooling Fan
1007	Gas Burner OBSOLETE
1016	Fenwal Control Board OBSOLETE
1069	Transformer
1070	Motor Switching Relay
1072	Gas Valve OBSOLETE
1252	Flange Bearing
1009	Convection Fan Motor
2426	8" Fan Blade (5/16" Bore, CW)
2413	Front Door Gasket
2428	Hangers w/bottom rack
1255	Food Rack
2436	Front Door Latch
2016	Front Door Hinge
2017	Gate Valve
2433	Teflon Axle Seal
1294	Ash Tote
1295	Ash Scoop
1296	Firebox Door Opener
322	Mobil Synthetic Worm Gear Oil SHC 634
304	Dubois FGG Extra High Temp. Food Machinery Grease