

Southern PRIDE

WOOD BURNING BBQ PITS & SMOKERS

XLR SERIES

XLR-600-SL, XLR-1000-SL, XLR-1400-SL, XLR-1600-4

INSTRUCTION MANUAL



**Southern
PRIDE**
Distributing, L.L.C.

472 South Mill Street, Alamo TN 38001

Sales: 800-851-8180 - Sales Fax: 618-993-5960

<http://www.southernpride.com> - sales@sopride.com - service@sopride.com

Service: 800-437-2679 - Service Fax: 618-993-0378 - parts@sopride.com



CONGRATULATIONS

In selecting Southern Pride, you have chosen the finest, most advanced and most fully automatic wood burning barbecue pit available. With us, “ It’s Simply, a Matter of Pride”.

Please read this Instruction Manual carefully prior to installation and operation of your Southern Pride pit. Proper installation, operation, cleaning and maintenance are essential for your satisfaction and safe operation.

KEEP THIS MANNUAL FOR REFERENCE

TABLE OF CONTENTS

Safety Information	3
Diagram of Controls & Components	4
Operating Instructions Manual Controls	6
Operating Instructions Digital Controls	8
Cold Weather Operations	10
Cleaning Instructions	11
Maintenance Schedule	12
Electrical Instructions	14
Burner Specification & Instructions	18
Venting Instructions	20
Replacement Parts List	23
Warranty	24

SAFETY INFORMATION

FOR YOUR SAFETY

IF YOU SMELL GAS . . .

1. Open windows.
2. Do not touch electrical switches.
3. Extinguish any open flames.
4. Immediately call your gas supplier.

DO NOT STORE OR USE GASOLINE OR OTHER FLAMMABLE VAPORS OR LIQUIDS IN THE VICINITY OF THIS OR ANY OTHER APPLIANCES.

1. The pit area **MUST** be kept clear and free of combustible materials, gasoline and other flammable vapors and liquids.
2. The flow of combustion and ventilating air **MUST NOT** be obstructed from reaching the pit.
3. The frame of the unit **MUST** be electrically grounded at all times. See “Electrical Instructions”.
4. Caution should be used when opening and closing the Firebox Door. The door is **HOT** during operation.
5. **DO NOT** remove service compartment access panels when unit is in operation or leave off during operation.
6. Gas burners require the services of an experienced Service Technician for proper setting and adjustment. If the burner does not appear to be operating properly, **DO NOT ATTEMPT TO ADJUST THE BURNER YOURSELF**, but call in a competent serviceman or contact Southern Pride.
7. **DO NOT** allow unqualified personnel to perform service work or adjustments on this unit. To do so will **VOID WARRANTY** and could result in a hazardous condition.
8. Be sure any new employees, who might operate the unit, are instructed on operation and safety information prior to operating the unit.
9. Caution: Ashes removed from the Firebox should be stored in a non-combustible container with a sealed lid only. Store ashes in a well ventilated area. **FUMES COULD BE HAZARDOUS.**
10. **WARNING: IT IS EXTREMELY IMPORTANT TO FOLLOW DAILY CLEANING INSTRUCTIONS. BUILDUP OF GREASE OR SOLIDS INSIDE THE PIT COULD RESULT IN A FIRE HAZARD.**
11. **KEEP THIS INSTRUCTION MANUAL FOR REFERENCE.**

SOUTHERN PRIDE'S XLR-SERIES BBQ OVENS

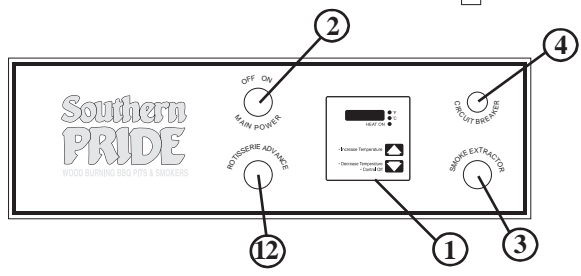
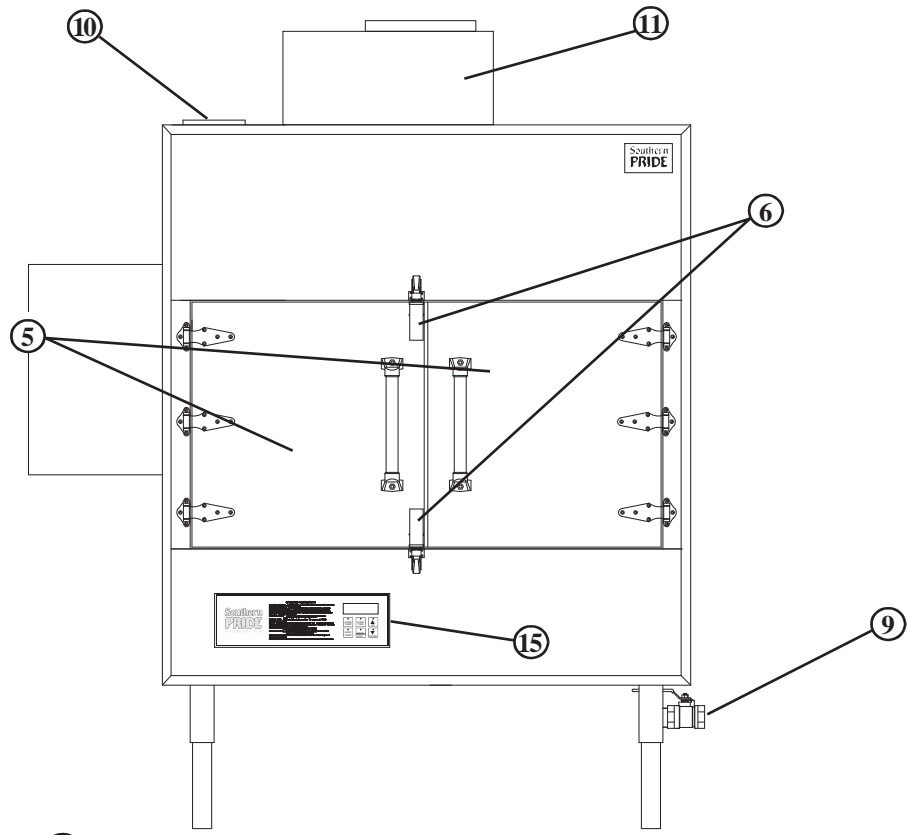

STANDARD CONTROLS

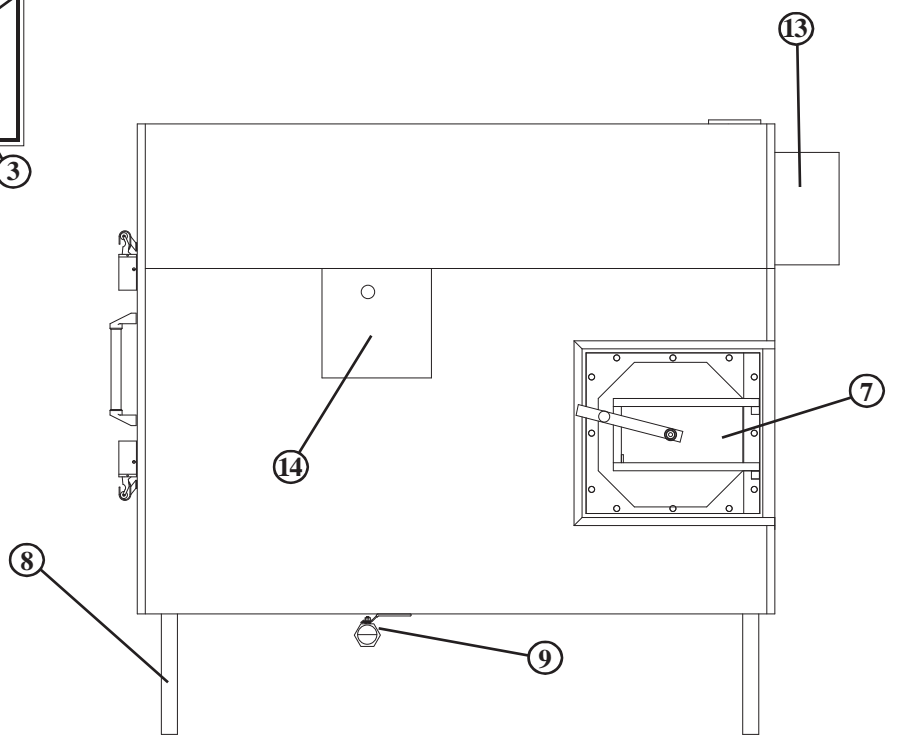

XLR Series

CONTROLS AND COMPONENTS

1. **CONTROL THERMOSTAT** - Adjustable temperature setting (140-325° F) with OFF position. Maintains desired Pit temperature by controlling the Gas Burner. Also displays the actual temperature inside the oven during the cooking cycle.
2. **MAIN POWER SWITCH** - Activates the Rotisserie, Convection Fan, Thermostat, and Red Indicator Lamp. (The Red Indicator Lamp on the Main Power Switch indicates when the switch is ON.)
3. **OPTIONAL SMOKE EXTRACTOR SWITCH** - Activates Smoke Extractor Damper, Exhaust Fan, and Blue Indicator Lamp. (The Blue Indicator Lamp on the Smoke Extractor Switch indicates when the switch is ON.) At the same time it de-activates the Burner and Red Indicator Lamp.
4. **CIRCUIT BREAKER** - Provides protection for the Rotisserie Drive Motor.
5. **MEAT LOADING DOORS** - For access to Racks and Pit interior.
6. **MEAT LOADING DOOR LATCHES** - Latches apply positive pressure and seal doors.
7. **FIREBOX DOOR** - Provides access for loading wood in the Firebox Chamber.
8. **CABINET LEGS** - Provide adjustment for leveling of the unit.
9. **DRAIN VALVE** - Is opened after each cooking to drain grease.
10. **FLUE COLLAR** - For connection of 6" Flue.
11. **OPTIONAL SMOKE EXTRACTOR DAMPER** - Closes to hold smoke inside pit while cooking and opens for Exhaust Fan to remove smoke when Smoke Extractor Switch is ON or when the Meat Loading Doors are Open.
12. **ROTISSERIE ADVANCE SWITCH** - Momentarily activates Rotisserie to advance the food racks for loading and unloading when the Meat Door is open, or the Main Power switch is OFF.
13. **CONVECTION FAN** - Provides air flow inside the Oven for even cooking.
14. **BEARING COVER** - Provides access for greasing Bearing.
15. **DIGITAL CONTROL (Optional)** - Provides precise control of the oven and adds special features, such as a Hold Mode, Automatic Cool Down prior to advancing into the Hold Mode and an Audible Alarm that sounds when the Cook Cycle is complete or when the control advances to the Hold Mode.

OPERATING INSTRUCTIONS FOR MANUAL CONTROLS

1. Load meat on the food racks. **DO NOT LET THE MEAT EXTEND BEYOND OR HANG OVER THE EDGE OF THE RACKS.**



CORRECT
Load meat on bottom rack first.



INCORRECT
May cause food to tip and meat to fall.
This could cause the Rotisserie to jam.

2. To advance the racks with the Meat Doors open, depress the Red Rotisserie Advance Button until the racks advance to the next position. Or if so equipped, depress the Rotisserie advance foot pedal.
3. After the meat is loaded, depress the Red Rotisserie Advance Button and allow the rotisserie to make one complete revolution. Check meat clearances to cabinet and all racks. If necessary, reposition meat on racks for maximum clearances.
4. Put a small amount of wood in the Firebox. Use 3-4 logs, 4"-6" inches in diameter, 12"-18" inches long. Use green or slightly seasoned hardwoods, fruitwoods, or charcoal.

CAUTION

**DO NOT USE DRY WOOD OR KINDLING. DO NOT OVERLOAD FIREBOX.
TOO MUCH WOOD CAN CAUSE OVER-HEATING OF THE PIT.**

**COALS AND ASHES FROM PREVIOUS COOKING MUST BE REMOVED BEFORE
LOADING WOOD. DO NOT ALLOW ASHES IN OR NEAR THE BURNER OPENING.
KEEP ALL LOGS AT LEAST 6 INCHES FROM THE BURNER.**



Correct way to load wood. Use 2, 3 or 4 hardwood logs, 4-6 inches in diameter, 12-18 inches long.



Use Ash Scraper to aid in the removal of ashes.

5. Be sure Firebox Door and Meat Loading Door Latches are secured in the closed position.
6. Turn the Main Power Switch to the **ON** position. The wood will be ignited and cooking temperature will be maintained automatically. (The red lamp on the Main Power Switch indicates when the switch is **ON**.)
7. Set the Thermostat to the desired temperature setting.
8. To check or unload meat on units with optional Smoke Extractor Switch; press and hold the Smoke Extractor Switch **ON**. (The blue lamp on the Smoke Extractor Switch indicates when the switch is **ON**.), Wait 20 seconds prior to opening the Meat Loading Doors.
9. When the meat is cooked; turn the Main Power Switch to the **OFF** position. On models with optional Smoke Extractor, depress the Smoke Extractor Switch to the **ON** position to activate the smoke extractor, and wait 20 seconds before opening the meat doors. To unload racks, depress the Rotisserie Advance Button until the racks advance to an unloading position.
10. After each cooking, remove the remaining wood and hot coals from Firebox, then open Drain Valve and drain grease while the pit is still warm.

CAUTION: BE SURE MEAT LOADING DOORS AND FIREBOX DOOR ARE SECURED IN THE CLOSED POSITION IMMEDIATELY FOLLOWING A COOKING AND DURING NON-USE PERIODS.

WARNING: DO NOT OPEN DRAIN VALVE WHILE PIT IS STILL IN OPERATION OR WHILE BURNING WOOD AND HOT COALS ARE STILL IN FIREBOX.

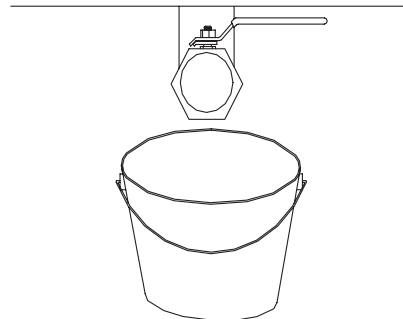

IMPORTANT

The Gas Burner is equipped with an automatic ignition system. To ignite; on ovens equipped with digital controls press the start / stop button one time to start a menu, or on ovens with standard controls turn the Main Power Switch to the **ON** position and set Thermostat to desired temperature. To shut the Burner **OFF**, on ovens with digital controls press and hold the start stop button until idle is displayed in the LED or on standard control ovens, turn the Main Power Switch to the **OFF** position.

OPERATING INSTRUCTIONS FOR DIGITAL CONTROLS

1. Load meat on the food racks. **DO NOT LET THE MEAT EXTEND BEYOND OR HANG OVER THE EDGE OF THE RACKS**



CORRECT
Load meat on bottom rack first.



INCORRECT
May cause food to tip and meat to fall.
This could cause the Rotisserie to jam.

2. To advance the racks with the Meat Doors open, **PRESS** the *up arrow* button until the racks advance to the next position.

3. After the meat is loaded, **PRESS** the *up arrow* button and allow the rotisserie to make one complete revolution. Check meat clearances to cabinet and all racks. If necessary reposition meat on racks for maximum clearances.



4. Put a small amount of wood in the Firebox. Use 3-4 logs 4"-6" in diameter, 12"-18" inches long. Use green or slightly seasoned hardwoods, fruitwoods, or charcoal.
5. Be sure Firebox Door and Meat Loading Door Latches are secured in the closed position.

To program a menu:

The menu consists of a cook temperature, cook time, and a choice of having the control advance to a hold mode after the cook time has elapsed or end the menu when the cook time has elapsed.

6. Control must be in the "IDLE" mode, if the control is "OFF" a press of any button will bring the control back to "IDLE".

7. **PRESS** the cook temp button, (tEnP 1 will appear in the LED display): **PRESS** the *up/down* buttons to obtain the desired cook temperature.

8. **PRESS** the cook time button, (tinE 1 will appear in the LED display): **PRESS** the *up/down* buttons to obtain the desired cook time.

9. **PRESS** the hold temp button, (HtEnp will appear in the LED display): **PRESS** the *up/down* buttons to obtain the desired hold temp, if a hold temp is not desired: **PRESS** the *down* button until "OFF" is displayed in the LED.

10. **Programming the menu is complete:** To start the menu, **PRESS** the *start/stop* button one time. The control will begin the menu.

11. To pause the menu **PRESS** the *start/stop* button one time, to resume the menu, **PRESS** the *start/stop* button again.

12. To cancel or stop the menu, **PRESS and hold** the *start/stop* button until “**IDLE**” is displayed in the **LED**.

When the cook cycle is complete:

13. Two action are possible after the cook time expires. If a hold temperature was programmed into the menu, then the control will momentarily sound an audible alarm, the smoke extractor will be automatically activated, for period of five minutes, to bring the oven temperature down closer to the programmed hold temperature, and then “**HOLD**” and the length of time the control has been in the hold mode will alternately flash in the **LED** display. The control will maintain the hold temperature until the *start/stop* button is depressed to “**END**” the menu, and bring the control to the “**IDLE**” mode. If the hold temperature was programmed to “**OFF**” then “**END**” will be displayed on the **LED** display, and an audible alarm will sound continuously until the *start/stop* button is depressed, to “**END**” the menu, and bring the control to the “**IDLE**” mode.

14. The control should be in the “**IDLE**” mode, (the burner, convection fan, and the rotisserie will be off).

15. When the menu is in progress a **PRESS** of the *down arrow* button will activate the smoke extractor, prior to opening the meat doors, if the doors are not opened the smoke extractor will go off after one minute and the menu will resume. If the doors are opened the menu will resume when the doors are closed.

16. The smoke extractor will automatically activate when the doors are opened, and the menu will resume again when the doors are closed.

17. When the doors are open a **PRESS** of the *up arrow* button will advance the rotisserie. If the oven is equipped with an optional rotisserie advance foot switch, a **PRESS** of the *foot pedal* will advance the rotisserie when the meat doors are open too.

18. Unload the meat from the racks, using the rotisserie advance button to rotate the racks, or if so equiped, the Rotisserie Advance Foot Pedal.

19. After each cooking, remove the remaining wood and coals from the firebox, then open the drain valve and drain the grease while the oven is still warm.

CAUTION: BE SURE THE MEAT LOADING DOORS AND THE FIREBOX DOOR ARE SECURED IN THE CLOSED POSITION IMMEDIATELY FOLLOWING A COOKING, AND DURING A NON-USE PERIOD.

WARNING: DO NOT OPEN THE GREASE DRAIN VALVE WHILE THE OVEN IS IN OPERATION, OR WHILE BURNING WOOD AND HOT COALS ARE STILL IN THE FIREBOX.

20. After the control has been in the “**IDLE**” mode for five minutes it will go to “**OFF**”. A **PRESS** of any button will bring the control back to “**IDLE**”.

SMOKER OVEN COLD WEATHER OPERATIONS FOR MOBILE OR THROUGH-THE-WALL APPLICATIONS

When temperatures drop below freezing there are issues that may develop. Listed below are some of those issues and ways to correct or reduce the effects of the problem.

1. Cold weather thickens the gearbox oil and at times it will cause the circuit breaker on the control panel to trip. There are several things that can be done during these cold weather conditions.
 - a. A preventative measure would be to keep rotisserie system rotating with thermostat at the lowest temperature setting.
 - b. If the circuit breaker has already tripped, you may be able to warm the gear box and oil up by letting the burner come on at the highest temp setting. Continue to warm the oven for 45-60 min and reset the panel circuit breaker by pushing in the center button on breaker.

Warning:

Allowing the panel circuit breaker to continually trip will eventually weaken the breaker so that it will trip at a level below the designed specification.

2. Grease in oven drain solidifies in cold weather. Listed below are things that can be done to reduce, or correct the effects of this problem.
 - a. Drain the oven after every cooking to purge the drainpipe of liquids before they solidify. In extreme cold weather conditions customers have had success wrapping the drainpipe with electric heat tape and insulating heat tape and pipe.
3. LED Displays an error 7
 - a. Ovens with digital controllers are effected by cold weather particularly when the oven is outside or in a through the wall installation. This error typically only happens when the oven has not been used for a significant duration of time that allowed the oven to become extremely cold usually temperatures below 32° F. The following action will generally clear the error 7 code.
 - b. Hold a cloth under warm water and wring water out, hold warm rag against top of thermocouple on the inside of oven for about 20-30 seconds. Remove rag and close door and start oven.

CLEANING INSTRUCTIONS

1. Remove ashes and coals from Firebox after each cooking.

Ash Disposal: Ashes should be placed in a non-combustible container with a tight fitting lid. The closed container of ashes should be placed on a non-combustible floor well away from all combustible material, pending final disposal.

Use Ash Scraper to aid in the removal of ashes and coals from the Firebox.

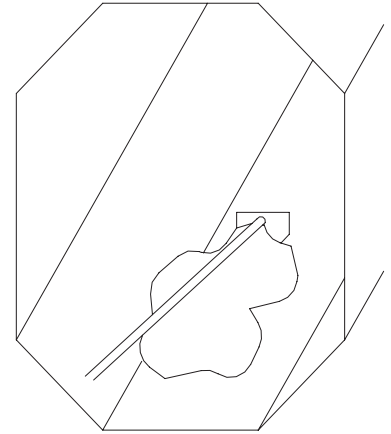
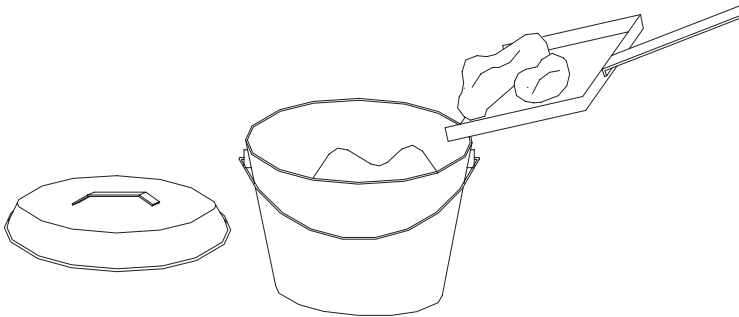

Place ashes and coals in a non-combustible container with a tight fitting lid. Place container outside well away from all combustible material.

CAUTION: Fumes could be hazardous.

2. Drain grease. (Be sure hot coals and wood are removed from the Firebox before opening drain valve.)

Open Drain Valve and drain Grease.

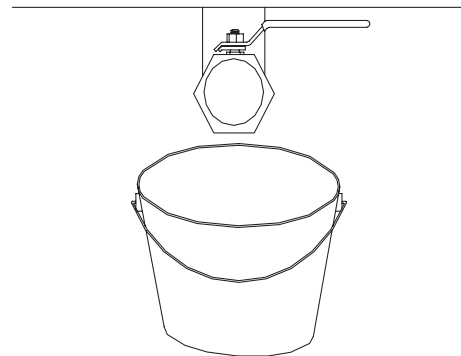

3. Remove food racks and clean thoroughly.

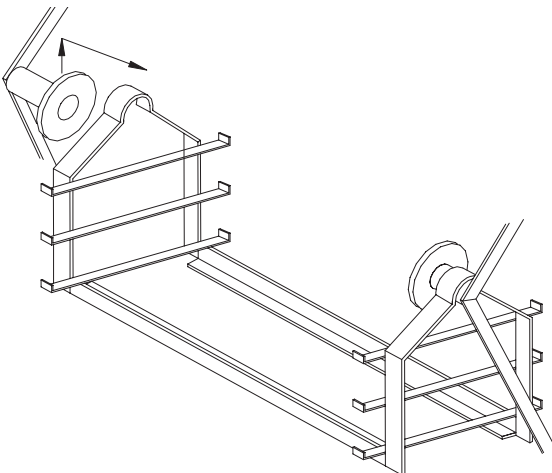

(Racks simply lift out of the brackets on the hangers.)

To remove food rack hangers, lift hanger and pull straight back over Rotisserie Wheel Stubs.

4. Thoroughly clean complete interior of pit. Use food service degreaser. Spray degreaser on the interior of the pit and allow it to set for 5-10 minutes. Rinse thoroughly with water hose or pressure washer. Drain through Drain Valve.

WARNING - IT IS EXTREMELY IMPORTANT TO FOLLOW THE ABOVE DAILY CLEANING PROCEDURES. GREASE OR BUILDUP OF GREASE OR SOLIDS INSIDE THE PIT COULD RESULT IN A FIRE HAZARD.

MAINTENANCE SCHEDULE

WEEKLY

Grease hubs on Rotisserie Wheels

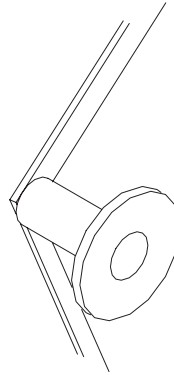

NOTE: Use a quality Extra High Temperature Food Machinery Grease with NSF “H-1” Rating for incidental food contact or equivalent.

3. Inspect Burner Head for accumulation of ashes and creosote.
Clean as needed.
4. Inspect Convection Fan Blade for buildup of solids or out of balance condition.
Clean or replace as needed.
5. Inspect meat Loading and Firebox Door Gaskets.
Replace if damaged or leaking.
6. Inspect Smoke Extractor Louver to be sure it closes completely.
Clean or repair as needed.
7. Inspect the Interlock Switch to be sure the Plunger and Roller move freely.
Lubricate with WD-40 or equivalent as needed.

INSIDE
DOOR
FRAME

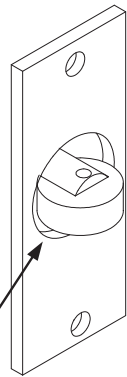

BI-MONTHLY INTERVAL

1. The Chimney Connector and Chimney should be inspected at least twice monthly to determine if creosote buildup has occurred.
2. The Flue Pipe should be carefully inspected. Remove any buildup of solids that has accumulated.

Creosote - Formation and need for removal:

When wood is burned slowly, it produces tar and other organic vapors, which combine with expelled moisture to form creosote. The creosote vapors condense in the relatively cool chimney flue of a slow burning fire. As a result, creosote residue accumulates on the flue lining. When ignited, this creosote makes an extremely hot fire.

IF CREOSOTE HAS ACCUMULATED, IT SHOULD BE REMOVED TO REDUCE THE RISK OF A CHIMNEY FIRE.

3 MONTH INTERVAL

1. Check the oil level in the Gearbox. To check, remove the Level Plug located on the right side of the Gearbox and see if the oil level is up to this point. If no oil is visible, add oil until overflow occurs.

NOTE: Use Synthetic Mobil SHC634 Worm Gear Speed reducer High Temperature Lubricant or equivalent.

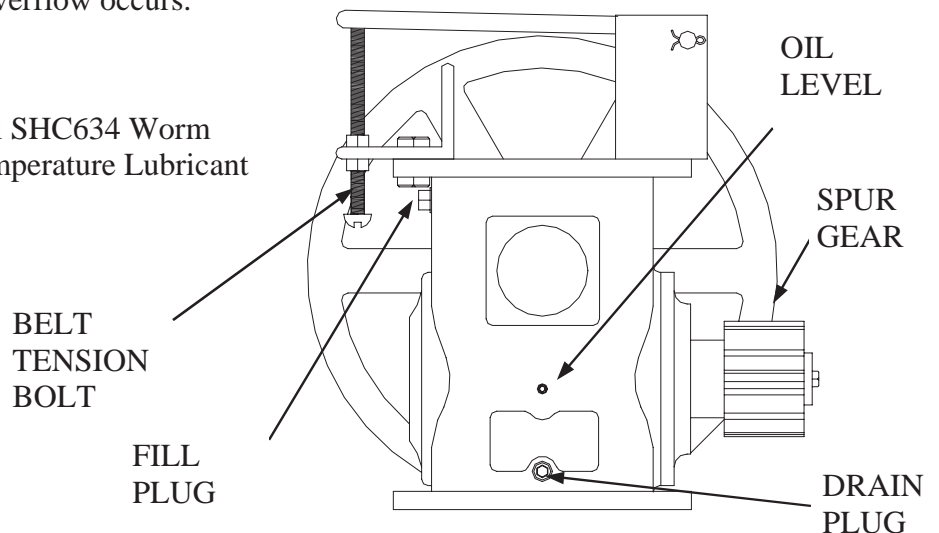

2. Check gears for proper mesh and for uneven wear. Re-align if necessary.
3. Spread thin layer of grease on small and large spur gear. (Do not use excessive amount).
4. Check belt tension. It should be approximately 1/4" flex when belt is depressed. Re-adjust if necessary. (To adjust belt, loosen nuts directly above gearbox and adjust upward or downward for proper adjustment, then re-tighten nuts.)
5. The flue pipe should be carefully and thoroughly cleaned if necessary.

ELECTRICAL INSTRUCTIONS

ELECTRICAL REQUIREMENTS:

120 Volts A.C., 60 hz.,
2 wire, single phase,
15 amp wiring required.

WARNING:

**CHASSIS MUST BE GROUNDED TO
PREVENT POSSIBLE SHOCK HAZARD.
DO NOT ASSUME A PLUMBING LINE
WILL PROVIDE SUCH A GROUND.**

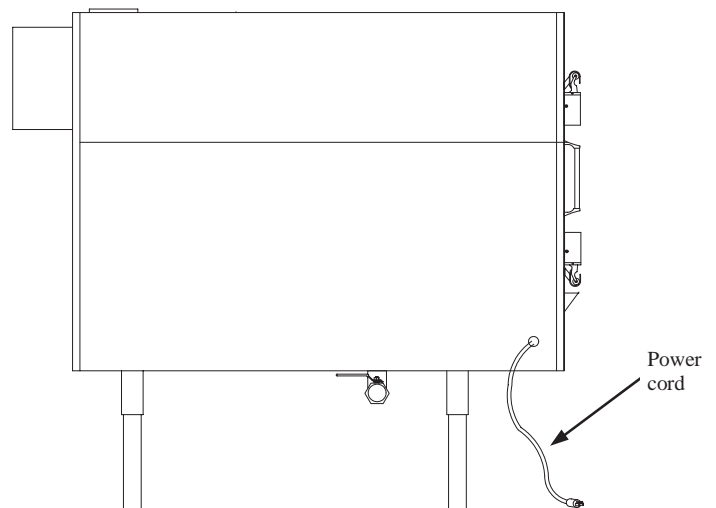

WARRANTY IS VOID IF UNIT IS CONNECTED TO ANY VOLTAGE OTHER THAN SPECIFIED ABOVE AND ON NAMEPLATE.

1. Electrician must provide the conduit and wire for hookup.
2. Power is to be left **OFF** throughout installation.
3. Electrical Service is connected via the factory supplied power cord located on the left front corner of the oven.

4. On models with optional Smoke Extractor, electrician must provide conduit and wire for hookup from Junction Box above the Smoke Extractor Motor on the top of the pit to the Exhaust fan. Make electrical connections inside the Junction box.

NOTE: THIS IS NOT A POWER SUPPLY CONNECTION. IT IS FOR A FAN CONNECTION ONLY.

**NOTE: 125 V.A.C., 1/4 hp
maximum connected load,
1100 cfm fan rating recom-
mended.**

5. If venting or gas connections are to be done later, be sure that power is **OFF**.

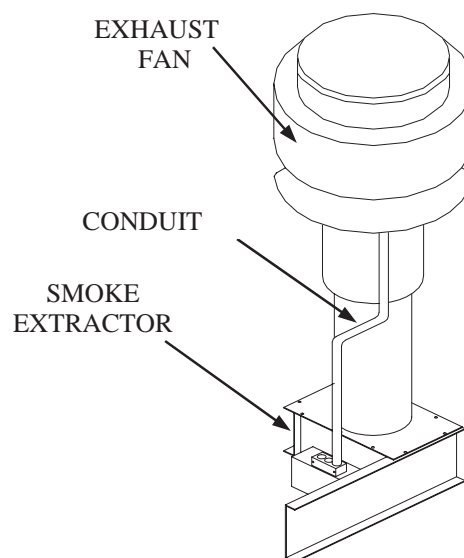

**XLR GAS OVEN WIRING DIAGRAM WITH
CV SERIES CONTROLLER AND WITH SMOKE EXTRACTOR**
Note: Firebox door switch is not applicable on XLR-1400 & 1600-4

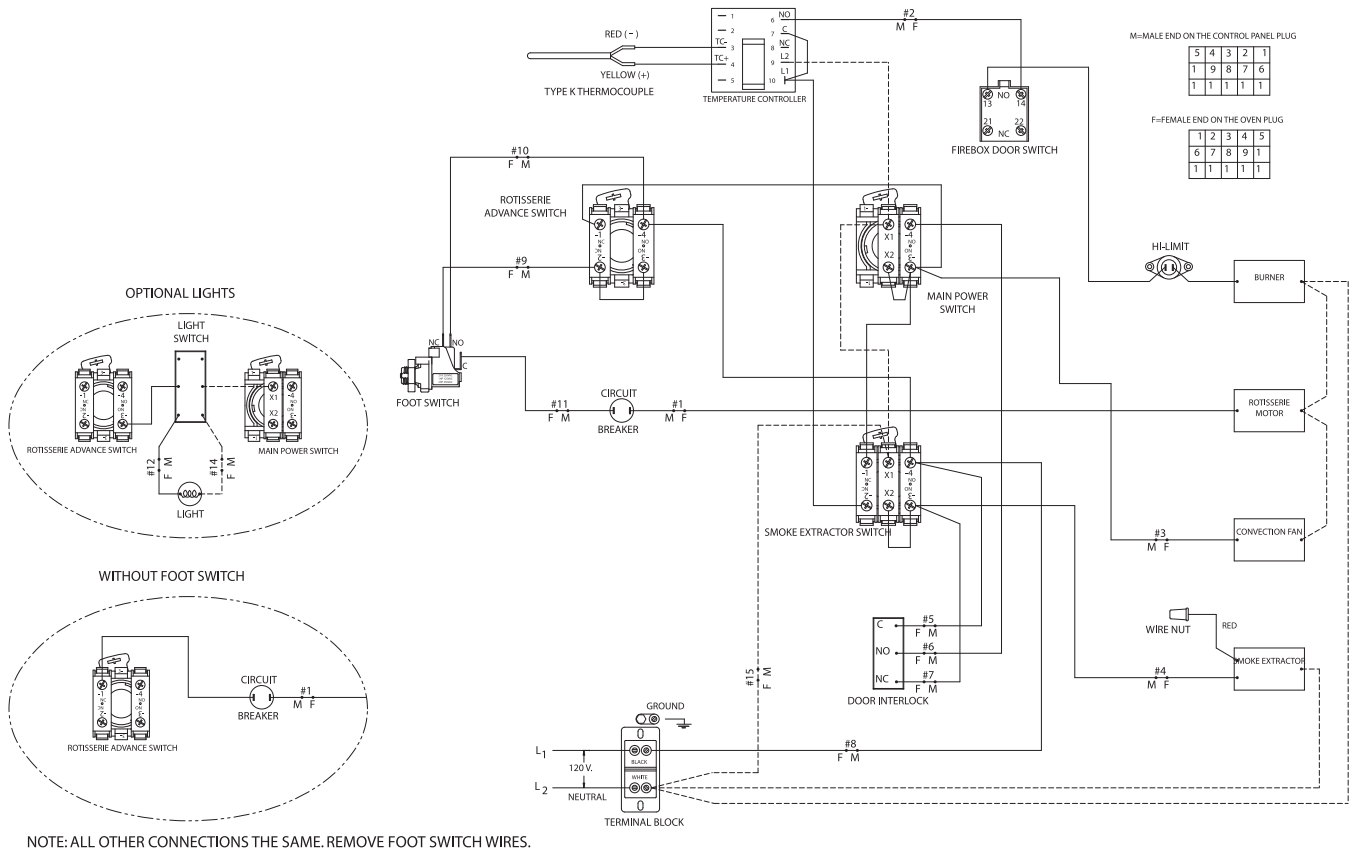

**XLR GAS OVEN WIRING DIAGRAM WITH
CV SERIES CONTROLLER AND WITHOUT SMOKE EXTRACTOR**
Note: Firebox door switch is not applicable on XLR-1400 & 1600-4

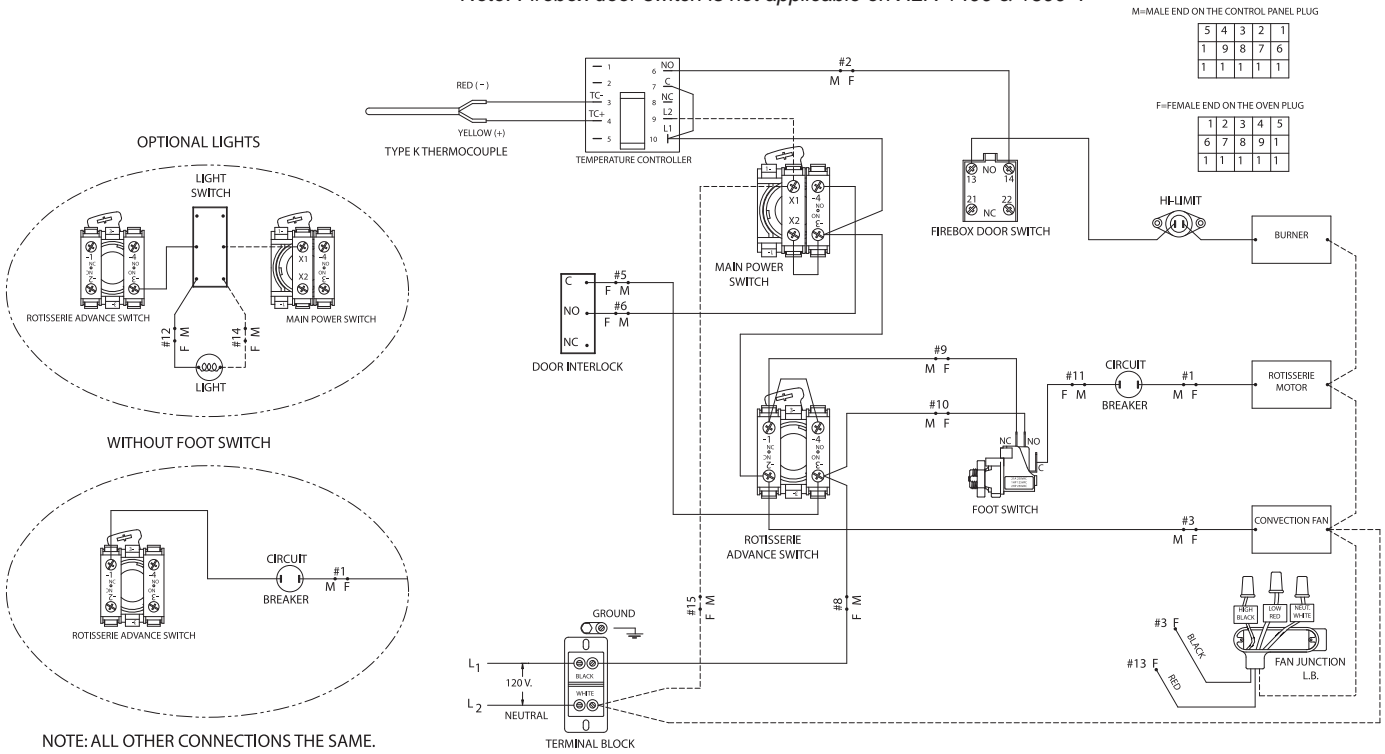

XLR GAS OVEN WIRING DIAGRAM DIGITAL CONTROL WITHOUT SMOKE EXTRACTOR

Note: Firebox door switch is not applicable on XLR-1400 & 1600-4

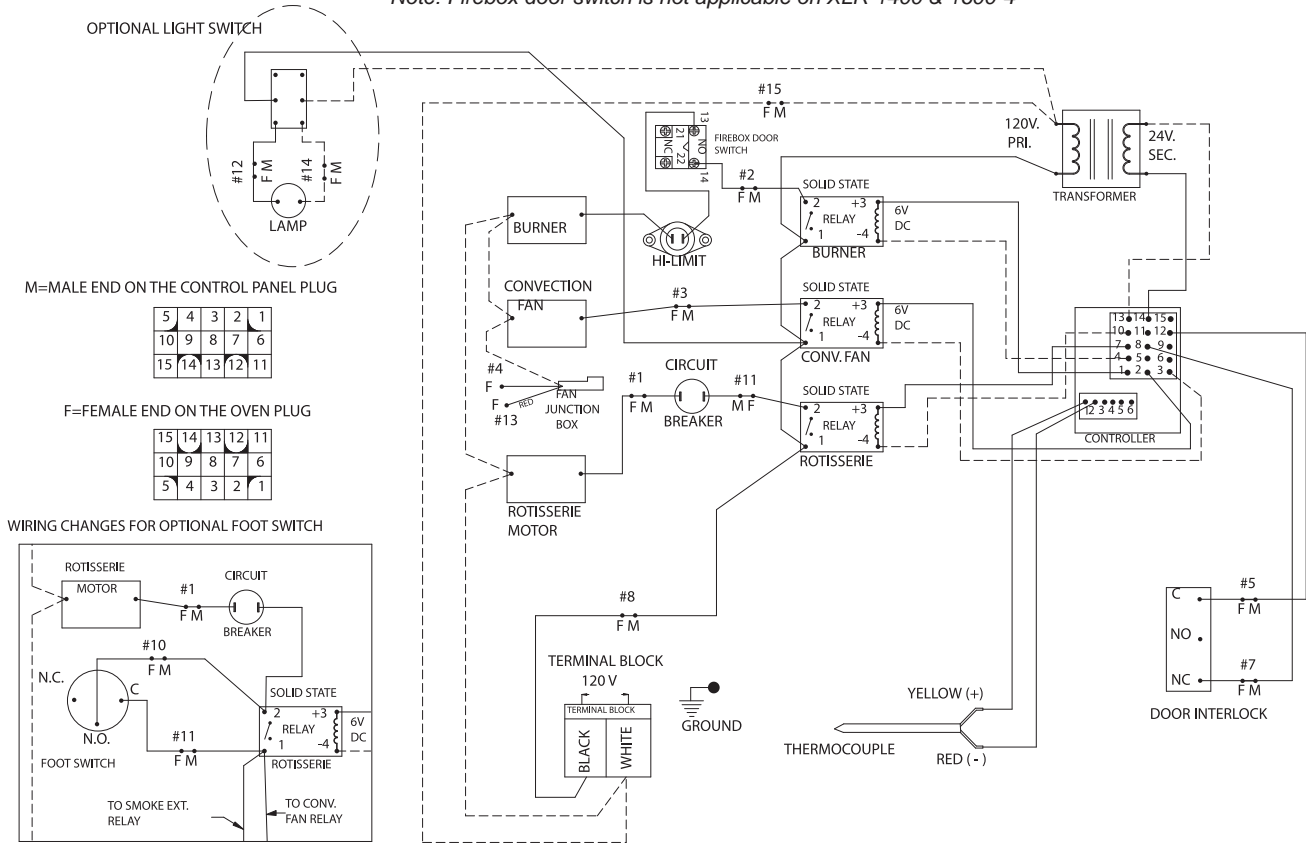

XLR GAS OVEN WIRING DIAGRAM DIGITAL CONTROL WITH SMOKE EXTRACTOR

Note: Firebox door switch is not applicable on XLR-1400 & 1600-4

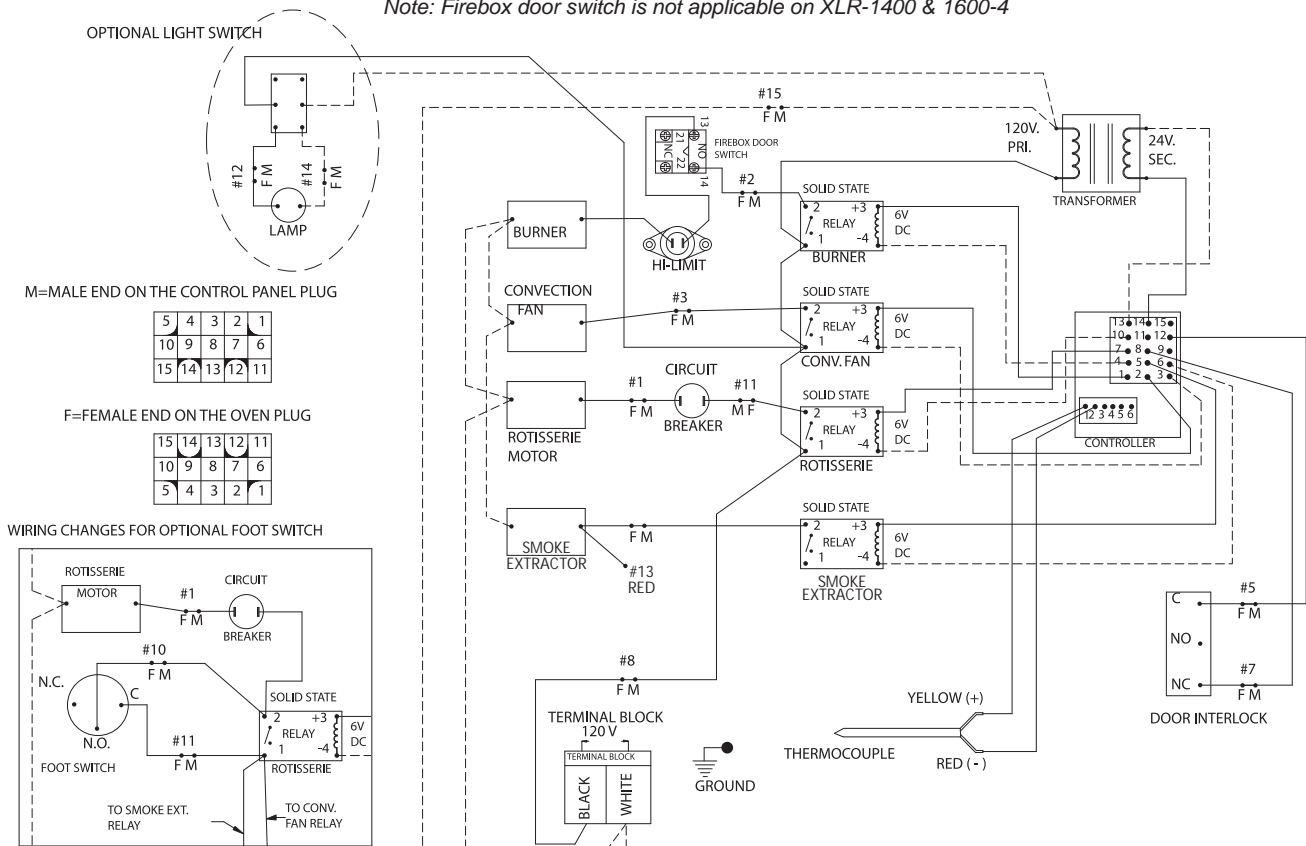

**XLR GAS OVEN WIRING DIAGRAM WITH
CV SERIES CONTROLLER AND WITH A TWO SPEED EXHAUST FAN**
Note: Firebox door switch is not applicable on XLR-1400 & 1600-4

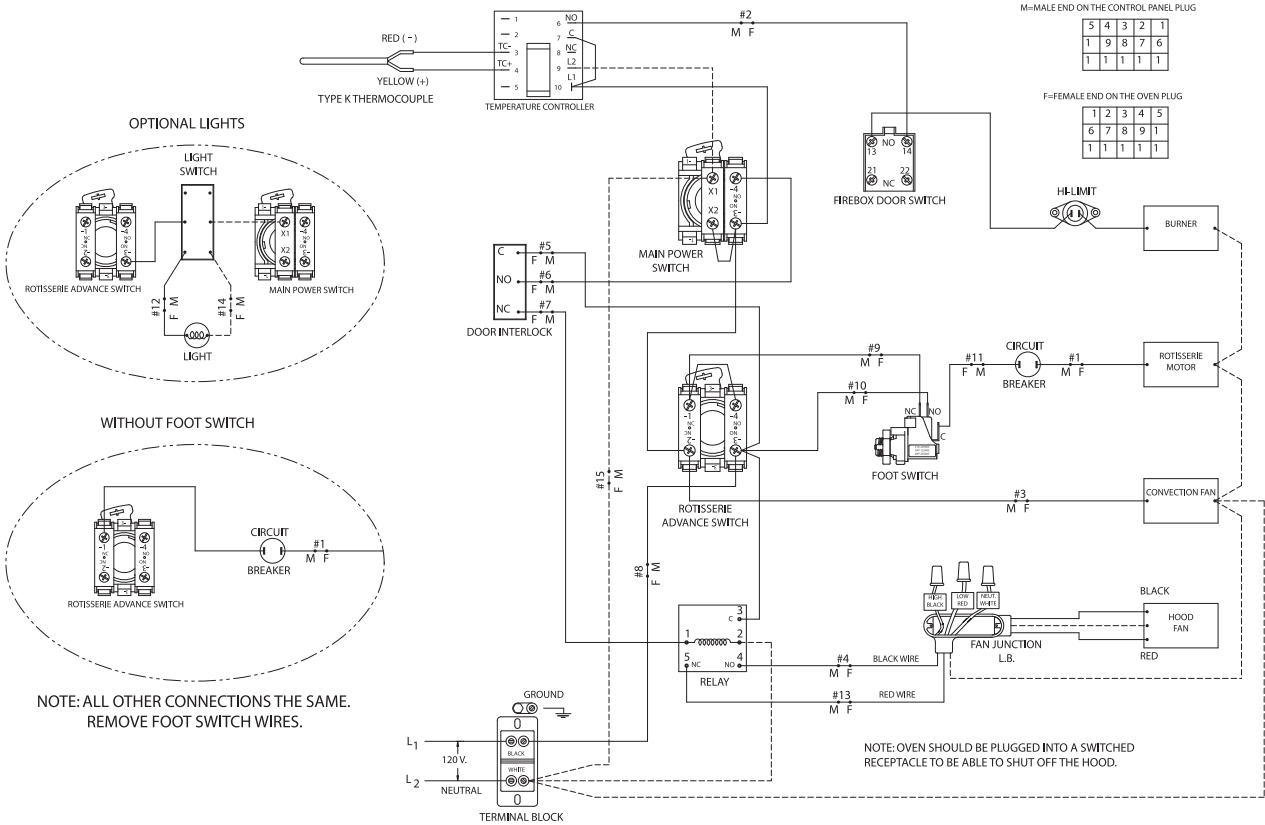

**XLR GAS OVEN WIRING DIAGRAM
DIGITAL XLR-SLSE WITH TWO SPEED EXHAUST FAN**
Note: Firebox door switch is not applicable on XLR-1400 & 1600-4

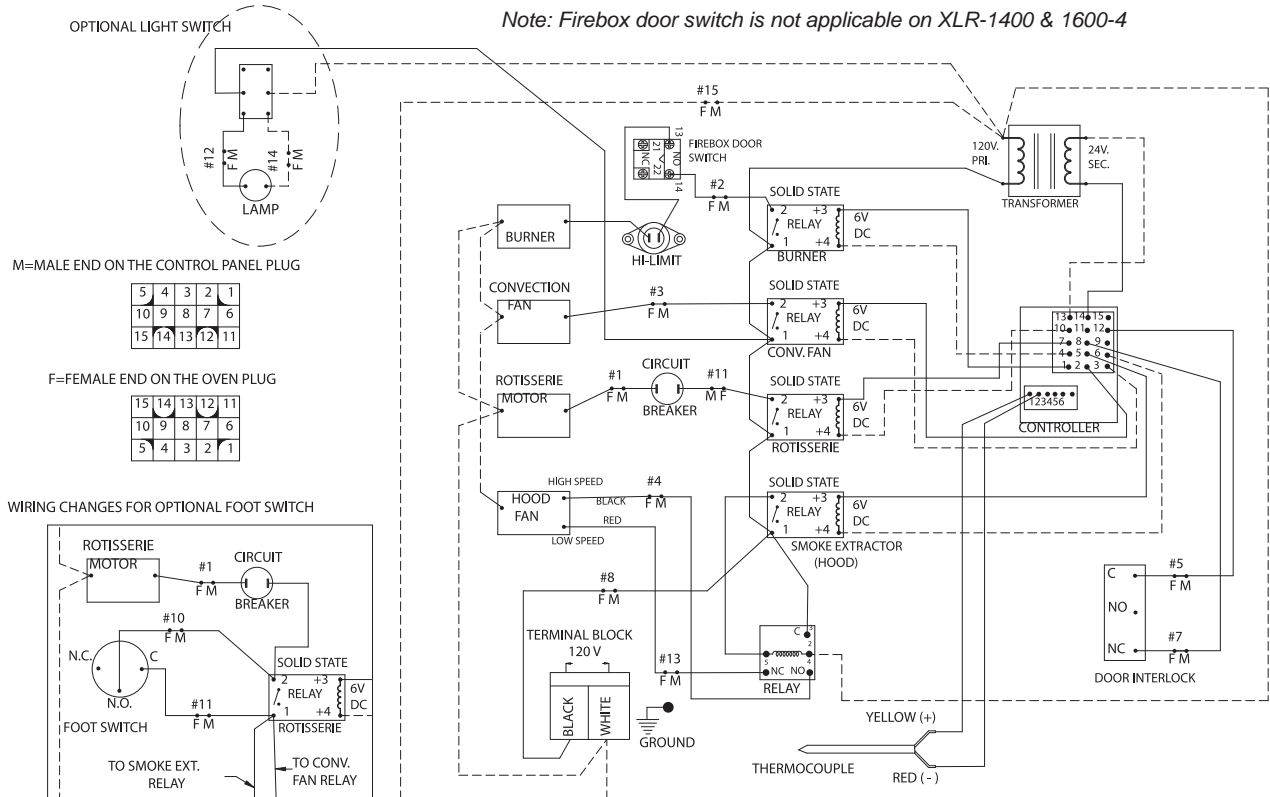

ITEMS TO CHECK BEFORE FIRING BURNER

IMPORTANT

WARNING: IMPROPER GAS HOOKUP WILL VOID WARRANTY AND COULD RESULT IN A HAZARDOUS CONDITION.

1. Gas line **MUST** be installed by a competent technician and in accordance with this Manual.
2. Gas line **MUST** include an easily accessible manual shutoff valve, drip leg and pressure gauge port.
3. Gas pipe size **MUST** be in accordance with the Pipe Capacity Chart in this Manual.
4. Gas line **MUST** be tested for leaks under pressure.
5. Gas Line **MUST** be purged to remove any air in the system.
6. Gas line pressure **MUST** be checked and **MUST NOT** exceed the maximum pressure specified in the Burner Specifications in this Manual.
7. Burner Orifice **MUST** correlate with the type of gas being supplied, as specified in the Burner Specifications in this Manual.

BURNER SPECIFICATIONS

Burner Model: Wayne P250-EP

Firing Capacity: 100,000 BTU/HR on Model XLR-600
 Maximum Input 150,000 BTU/HR on Model XLR-1000
 125,000 BTU/HR on Model XLR-1400
 200,000 BTU/HR on Model XLR-1600-4 (Single Burner)
 150,000 BTU/HR each on Model XLR-1600-4 (Dual Burner)

Fuels: Natural and L.P. Gases

Electrical: 120 V.A.C., 60 hz, 1 ph

Orifice Sizes:	XLR-600	XLR-1000	XLR-1400	XLR-1600-4 Single	XLR-1600-4 Dual
Natural Gas	#14	#1	#5	G	#1
L.P. Gas	#35	#29	1/8"	#22	#29

NOTE: Orifice and valve setting must correlate with type of gas being supplied.

Gas Supply Line Pressure: Natural - 4.5" W.C. Minimum 10.0" W.C. Maximum
 L.P. - 11.0" W.C. Minimum 13.0" W.C. Maximum

MANIFOLD PRESSURE: Natural - 3.5" W.C. L.P. - 10.0" W.C.

GAS VALVE: Control Knob must be ON.

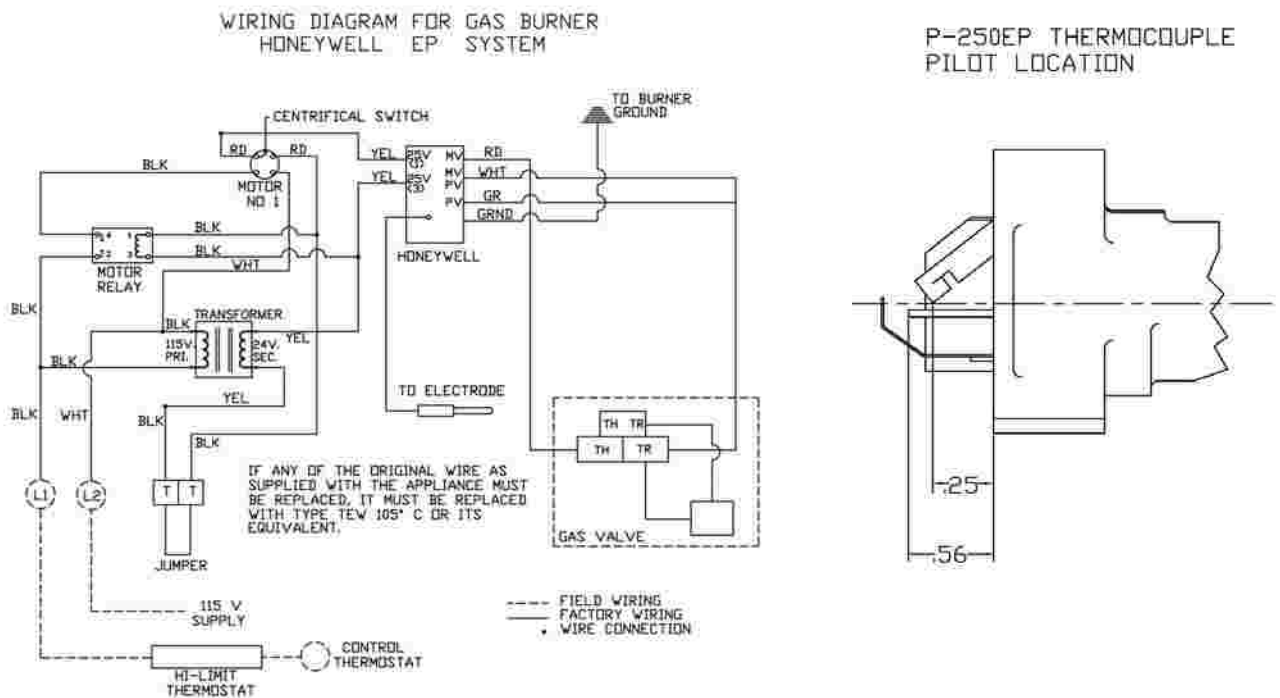

VENTING INSTRUCTIONS

1. It is recommended that the model XLR-Series ovens be vented as shown on page 21.
2. It is recommended that Local Code Officials and a Commercial Kitchen Ventilation Contractor be consulted prior to installation.
3. Provisions must be made for adequate air supply for the oven. If the oven is to be installed in a sealed room or building utilizing exhaust fans, the room must be supplied with a return air system. Return air must be equal or in excess of the exhausted air.
4. Unit must be level for proper grease drainage.
5. Minimum spacing to combustible materials:
 - Back-2" (although 10" is recommended for servicing the unit)
 - Left Side-18" (access for service) Note: If provision is made for service access, Left Side clearance can be reduced to 2".
 - Right Side-24" Access to load and unload firebox.
 - Top-18"
 - Front-48" (access for loading and unloading product)
 - Chimney Connectors-18"
 - Floor-May be combustible material.

NOTE: On ovens that have the reverse firebox or mirror image option, (Facing the meat loading doors the firebox door is on the right) The minimum clearance dimensions for the left side and right side will be reversed.

NOTE: For flush mount, use BBR Insulation Kit #2908.

VENTING INSTALLATIONS

INSIDE INSTALLATION

VSP HOOD SYSTEM: Purchase through Southern Pride.

MODEL VSP HOODS are U/L Listed to the applicable Southern Pride oven . (VSP Hoods not available for XLR-1600 models)

HOOD SYSTEM TO INCLUDE;

1. Ventilation Hood.
2. Two speed fan (1320/2000).
3. Curb with vented extension and hinge kit (Specify roof pitch).
4. Grease capture trough.
5. Combustion chamber flue vent

SUPPLIED BY CUSTOMER:

6. Duct from hood to fan.
7. Hood Installation

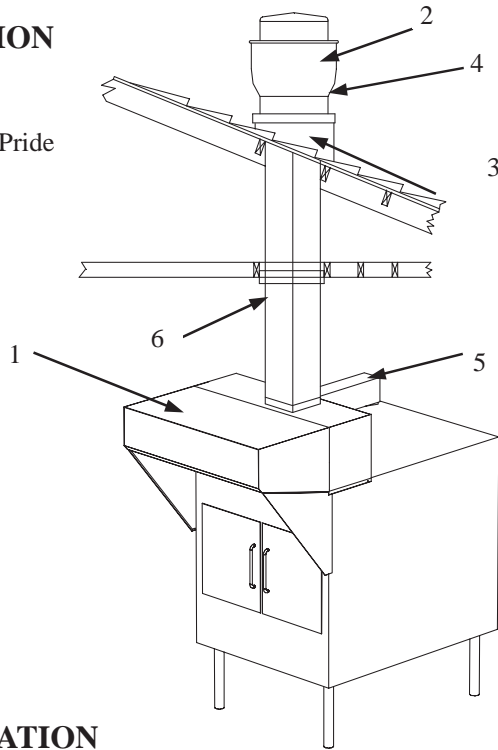

ALTERNATE INSIDE INSTALLATION

ALL MODEL OVENS MAY ALSO BE INSTALLED UNDER A CANOPY HOOD RATED FOR COMMERCIAL COOKING APPLIANCES.

THROUGH THE WALL - DIRECT VENT INSTALLATION

NOTE: When installing an Oven through a wall constructed of combustible material, use the **Southern Pride Insulation Kit** between the oven and the wall.

NOTE: The room that the face of the oven is installed into should have a balanced or positive air pressure. If the room has negative air pressure smoke could escape into the room during operation.

SUPPLIED BY SOUTHERN PRIDE;

Smoke Extractor Damper with 10" chimney adapter plate.

SUPPLIED BY CUSTOMER;

6" All Fuel Chimney, 6" Rain Cap, and all accessories necessary for installation of the 6" chimney.

10" All Fuel Chimney, Exhaust Fan (NOTE: fan must be listed for use as a commercial kitchen ventilator), fan curb, and all accessories necessary for installation of the smoke extractor system.

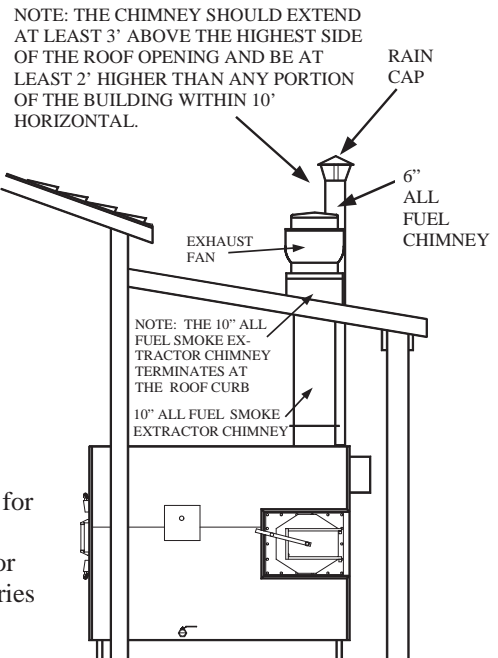

NOTE: ANY VENTILATION SYSTEM MUST BE INSTALLED IN ACCORDANCE WITH LOCAL CODES. CONSULT WITH LOCAL CODE OFFICIALS AND A COMMERCIAL KITCHEN VENTILATION CONTRACTOR PRIOR TO INSTALLATION.

GAS PIPING INSTRUCTIONS

1. **READ ALL GAS PIPING INSTRUCTIONS CAREFULLY BEFORE MAKING GAS CONNECTIONS.**

WARNING: IMPROPER GAS HOOKUP WILL VOID WARRANTY AND COULD RESULT IN HAZARDOUS CONDITION.

2. Connect the gas line to the 1/2 inch piping that extends from the Gas Burner. A 1/2 inch N.P.T. fitting is required.

NOTE: All piping must comply with local codes and ordinances of the National Gas Code ANSI Z 223.1 - 1974 and NFPA #54.

3. The gas line should be a separate supply direct from the meter to the Burner. It is recommended that a new pipe be used and located so that a minimum amount of work will be required in future servicing. The piping should be so installed as to be durable, substantial, and gas tight. It should be free from cutting burrs and defects in structure and threading. Cast iron fittings or aluminum tubing should not be used for the main gas circuit. Joint compounds (pipe dope) should be used sparingly on male threads only and be approved for all gases.

NOTE: The building structure should not be weakened by installation of the gas piping. The piping should not be supported by other piping, but should be firmly supported by pipe hooks, straps, bands, or hangers. Butt or lap welded pipe should not be bent.

4. The Pipe Capacity Chart must be used to determine the size pipe to use from the meter to the Burner.

PIPE SIZE	PIPE CAPACITY CHART	
	MAXIMUM LENGTH FT.	
	NAT.	L.P.
3/8	-	10
1/2	10	30
3/4	70	150
1	200	250
1 1/4	250	-

FOR GAS PRESSURE OF 0.5 PSIG OR LESS BASED ON A 0.6 AND 1.5 SPECIFIC GRAVITY GAS.

5. **TEST PIPING FOR LEAKS.** Before turning gas under pressure into piping, all openings from which gas can escape must be closed. Immediately after turning on gas, the system should be checked for leaks. This can be done by watching the 1/2 cubic foot test dial for 5 minutes to show any movement, or by soaping each pipe connection and watching for bubbles. If leak is found, make the necessary repairs and repeat the above test.

NOTE: Defective pipes or fittings should be replaced and not repaired. Never use a flame or fire of any form to locate gas leaks; use a soap solution.

6. After the piping and meter have been checked completely, **PURGE THE SYSTEM OF AIR. DO NOT** bleed the air inside the unit. Be sure to relight all the gas pilots on other appliances.

NOTE: The burner and its individual shutoff valve must be disconnected from the gas supply piping system during any pressure testing at excess of 1/2 psig.

XLR-600, XLR-1000, XLR-1400, & XLR-1600-4 REPLACEMENT PARTS LIST

Controls & Switches

1004	Bi Metal High Limit
1005	Door Interlock Switch
1002	CV Control Thermostat / Thermometer
1080C	Main Power Switch - Red Light
1081C	Smoke Extractor Switch - Blue Light
1082C	Rotisserie Advance Switch - Red Mushroom Head
1068	4 AMP Circuit Breaker (XLR-600, XLR-1000 & XLR-1400 With 12" Wide Food Racks)
1068-8	8 AMP Circuit Breaker (XLR-1400 with 18" Wide Food Racks & XLR-1600-4 with 12" Wide Food Racks)
1068-15	15 AMP Circuit Breaker XLR-1600-4 with 18" Wide Food Racks
1098-3	Thermocouple 3 Ft. Type "K"
1098-4	Thermocouple 4 Ft. Type "K" (XLR-1600-4 Only)
1090	Digital Cook & Hold Temperature Control
1091	10 AMP SSR (Solid State Relay)

Burner Parts

1041	Gas Burner (Specify Oven Model and Type of Gas When Ordering)
1062	24 Volt Step Down Transformer
1070	Motor Switch Relay
1076	Blower Motor
1084	Combination Gas Valve (Specify Natural or LP Gas)
1085	Electrode - Igniter / Pilot Assembly
1086	High Voltage Lead
1087	Ignition Control Module

Convection Fan Parts

1040	Convection Fan Motor - CW Clock-wise Rotation
1040-CCW	Convection Fan Motor - CCW Counter Clock-wise Rotation (XLR-1600-4 Only)
2426	8" Cooling Fan Blade - CW (Outside Blade)
2428L	10" Convection Fan Blade - CW (Inside Blade)
2426-1	8" Cooling Fan Blade - CCW (Outside Blade) XLR-1600-4 Only
2428-1	10" Convection Fan Blade - CCW (Inside Blade) XLR-1600-4 Only

Rotisserie System Parts

Drive system

1023-1	Gearbox Drive Motor XLR-1400 With 18" Wide Food Racks & XLR-1600-4 with 12" Wide Food Racks
1029	Gearbox Drive Motor XLR-1600-4 With 18" Wide Food Racks
1078	Gearbox Drive Motor
1252	Rotisserie Axle Bearing XLR-600
1850	Gearbox Only XLR-600
1852QD	Large Drive Gear XLR-600
1853	Small Drive Gear XLR-600
1855	V-Belt XLR-600
2017	QD Bushing For Large Drive Gear XLR-600
2019	V-Belt (XLR-1400 Gearbox & XLR-1600-4 Gearbox Oven with 12" Wide Food Racks)
2023QD	Large Drive Gear XLR-1000, XLR-1400 & XLR-1600-4
2024	Gearbox Only XLR-1000, XLR-1400 & XLR-1600-4 With 12" Food Racks
2026	QD Bushing For Large Drive Gear XLR-1000, XLR-1400 & XLR-1600-4
2052	Small Drive Gear XLR-1600-4 With 18" Food Racks

XLR-600, XLR-1000, XLR-1400, & XLR-1600-4 REPLACEMENT PARTS LIST

2053	Gearbox Only XLR-1600-4 With 18" Food Racks
2054	V-Belt XLR-1600-4 With 18" Food Racks
2025	Rotisserie Axle Bearing
4218	Gearbox Assembly XLR-1600-4 With 18" Food Racks
4200	Gearbox Assembly XLR-1000, XLR-1400
4207	Gearbox Assembly XLR-1600-4 With 12" Food Racks
4614	Gearbox Assembly XLR-600

Food Racks

2032	Food Rack 18" x 48" (Nickel Chrome) XLR-1600-4 With 18" Food Racks
2034	Food Rack 12" x 48" (Nickel Chrome) XLR-1600-4
2174	Food Rack 18" x 22" (Nickel Chrome) XLR-600
2180	Food Rack 12" x 42" (Nickel Chrome) XLR-1400
2188A	Food Rack 18" x 42" (Nickel Chrome) XLR-1000 & XLR-1400 With 18" Food Racks

Food Rack Hangers

7000	Food Rack Hanger XLR-1600-4 (7 Tier - 12" Wide Food Racks)
7010	Food Rack Hanger XLR-1400 (12" Wide Food Racks)
8124	Food Rack Hanger XLR-600
8142	Food Rack Hanger XLR-1000
9232	Food Rack Hanger XLR-1400 (18" Wide Food Racks)
9237-5	Food Rack Hanger XLR-1600-4 (18" Wide Food Racks)

Rotisserie Wheels

8126	Rotisserie Wheel XLR-600 & XLR-1000
9021	Rotisserie Wheel - Right XLR-1400 With 12" Food Rack
9022	Rotisserie Wheel - Left XLR-1400 With 12" Food Racks
9026	Rotisserie Wheel - Right XLR-1600-4 With 12" Food Rack
9027	Rotisserie Wheel - Left XLR-1600-4 With 12" Food Rack
9240	Rotisserie Wheel XLR-1600-4 With 18" Food Racks
9245	Rotisserie Wheel - Right XLR-1400 With 18" Food Racks
9246	Rotisserie Wheel - Left XLR-1400 With 18" Food Racks

Meat Loading Door Parts

2116	Door Hinge
2112	Door Closer Latch
2112-1	Door Closer Catch
4189G	Door Gasket XLR-1400
4190G	Door Gasket XLR-1600-4
4300G	Door Gasket XLR-1000
4306G	Door Gasket XLR-600

Firebox Door Parts

2029-1	Firebox Door Gasket 1"x1"
2029-2	Firebox Door Gasket Clamp

Miscellaneous Parts

304	FGG Food Grade Grease
2467-1	2" Full Port Ball Valve (Grease Drain)
9053-3	Firebox Ash Scraper
1060	Smoke Extractor Actuator Motor

**ONE YEAR LIMITED WARRANTY
(CONSULT FACTORY FOR DETAILS)
90 DAY LABOR WARRANTY (PRE AUTHORIZED)**

Southern Pride guarantees all new equipment of its manufacture to be free of defects in material and factory workmanship for a period of one year provided that the equipment is installed in the Continental United States, Alaska, or Hawaii and operated according to the Owner's Manual while located at the original address of installation, the Warranty Registration Card has been completed and returned to the factory within fifteen (15) days after installation, and a start-up has been performed by an authorized service agent.

Southern Pride's obligation under this warranty is limited to one of the following options with the option applicable to be selected by Southern Pride at the sole discretion of Southern Pride.

1. Owner is to return part, freight PREPAID. Southern Pride is to repair it at own expense if defective, and ship part back to owner freight collect.
2. Southern Pride is to furnish replacement part, freight collect, without requesting return of the defective part.
3. Southern Pride is to furnish replacement part, freight collect, in exchange for return of the defective part, freight collect.

Under certain circumstances, Southern Pride will reimburse owner for limited labor costs in replacing parts during a period of not more than ninety (90) days after installation, **(provided that work is authorized prior to being done and confirmed by Southern Pride's Service Manager.)**

Because Southern Pride does not and cannot control the owner's installation, use and maintenance of equipment manufactured by Southern Pride, this warranty does not cover: any equipment installed improperly; any equipment calibrated after start-up and acceptance; any component disassembled in the field, damage due to improper cleaning, i.e. burner (hosing or "watering down" machines will cause electrical failures not covered by warranty); blown fuses, light bulbs, gaskets, electric elements and accessory components not installed or manufactured by Southern Pride. Shipping damage must be reported to the carrier and is not covered under this warranty.

Southern Pride will not be liable for damage as a result of improper installation, misuse, abuse, alteration of original design, incorrect voltage, **unauthorized service**, or breakage of fragile items. Southern Pride will not be liable for any loss or consequential damage or expense accruing directly or indirectly from the use of equipment covered by this warranty, including any production or product losses or other damages which may occur as a result of equipment malfunction or failure. This warranty does not cover cooking performance, which is a function of food types, textures, temperatures and other variables chosen by the owner and over which Southern Pride has no control. The effect of corrosion, fire and normal wear on the equipment or component parts is not covered by this warranty. This warranty does not apply to damage caused by accident or to damage caused by the negligence of the owner and the employees of the owner, or to damage caused by lightning generated electrical current or any other Act of God whatsoever. This warranty does not apply to any equipment bearing a serial number which has been tampered with or altered.

This warranty is exclusive and is in lieu of all other warranties, express or implied, including any implied warranty or merchantability or fitness for particular purpose, each of which is hereby expressly disclaimed. The remedies described above are exclusive, and, in no event shall Southern Pride be liable for special, consequential or incidental damages for the breach or delay in performance of warranty.

TERMS AND CONDITIONS

For purposes of definition and interpretation, the term "Seller" as used herein refers to Southern Pride, and the term "Buyer" refers to the originator of a specific purchase order to Southern Pride.

Possession of a price list does not necessarily constitute an offer to sell by Southern Pride. Prices and specifications are subject to change without notice. All items will be invoiced at prices in effect at time of shipment. Equipment prices do not include federal, state, city or local taxes which may apply, and all sales are subject thereto. No order, whether written or oral, shall result in a contract, unless it is accepted and acknowledged in writing by Seller at Seller's office in Marion, Illinois.

Shipping weights are approximate and all prices are quoted F.O.B. Marion, Illinois. All "common carrier" shipped equipment shall be domestic crated; all others shall be uncrated and subject to delivery charge per zone chart. Any equipment held for shipment upon Buyer's request beyond the delivery date specified on original purchase order, will be due and payable within terms and will result in storage charges.

Delivery estimates are figured from date written orders are received and accepted by Seller. Seller will meet Buyer's delivery request as nearly as possible but does not guarantee shipment nor delivery on any particular date. Seller reserves the right to ship merchandise via any responsible carrier. Seller's responsibility ceases upon acceptance by carrier. Buyer is expected to examine contents of shipments and immediately report any damage to carrier authorities.

Payment terms shall be 30% deposit with order; balance prior to delivery unless otherwise agreed in writing by Seller. Returns of any merchandise may not be made without Seller's written approval, prior to return. Seller shall impose a 20% restocking charge for handling of any returns. All cancellations must be in writing. Cancellations are also subject to a 20% fee.