

OPERATOR MANUAL

IMPORTANT INFORMATION, KEEP FOR OPERATOR

This manual provides information for:

SOUTHERN PRIDE

VSP HOOD

FOR A SOUTHERN PRIDE BBQ OVEN



UL file # for Southern Pride oven – MH11943

UL file # for Avtec VSP Hood – MH12966

**THIS MANUAL MUST BE RETAINED FOR FUTURE REFERENCE.
READ, UNDERSTAND AND FOLLOW THE INSTRUCTIONS AND
WARNINGS CONTAINED IN THIS MANUAL.**

NOTIFY CARRIER OF DAMAGE AT ONCE

It is the responsibility of the consignee to inspect the container upon receipt of same and to determine the possibility of any damage, including concealed damage. Unified Brands suggests that if you are suspicious of damage to make a notation on the delivery receipt. It will be the responsibility of the consignee to file a claim with the carrier. We recommend that you do so at once.

Manufacture Service/Questions, call Southern Pride at 800-851-8180.

Information contained in this document is known to be current and accurate at the time of printing/creation. Unified Brands recommends referencing our product line websites, unifiedbrands.net, for the most updated product information and specifications.

PART NUMBER SP-1/06, REV. A (07/11)

Southern Pride Distributing
472 South Mill St
Alamo, TN 38001
800-851-8180
fax 618-993-5960
www.southern-pride.com

Table of Contents

Safety Procedures	page 2
Important Product Information	page 3
Regulatory Information	page 4
Option 1: Door Installation	page 5
Option 2: Through the Wall Installation	page 6
Option 3: Through the Wall Installation with Curb Assembly	page 7
Installation Instructions: Standard VSP Top Collar	page 8
Installation Instructions: Rear Collar VSP	page 9
Installation Instructions: Exhaust Fan & Duct for Option 3	page 10
Electrical Connection	page 11
Warranty	page 12-14
Ventilation Maintenance Guide	page 15
Diagrams	page 16-28

Safety Procedures

Do not attempt to service this unit yourself as removing covers may cause unnecessary exposure to dangerous voltage.

Never connect the unit to a power source while standing in water. Wet hands and wet floors should be avoided when connecting any electrical appliance to a power outlet.

Fans may have multiple power connections. Make sure all fans are isolated from power prior to performing maintenance.

Important Product Information

Warranty AVTEC INDUSTRIES INC. warrants to the original purchaser for use of our products, that any part thereof which proves to be defective in material or workmanship under normal use within one year from date of installation, will be replaced free of charge. Labor to replace such parts is warranted for one year from installation. All warranty labor to be performed during regular working hours, with no overtime premium.

All warranty service must be authorized by the factory and be performed by AVTEC's authorized service personnel.

This warranty is limited to the United States and Canada.

This warranty does not apply to any damage resulting from shipping, improper installation, accident, unauthorized alteration, local codes not previously brought to the attention of AVTEC, misuse, or abuse; and does not cover loss of food, other products or damage to equipment or property resulting from mechanical or electrical failure.

AVTEC neither makes nor assumes and does not authorize any other person to assume any other obligation of liability in connection with its products other than that covered in this warranty.

General All Avtec (Unified Brands) food service equipment is backed by some of the best warranties in the foodservice industry and by our professional staff of service technicians. **Retain this manual for future reference.**

NOTICE: Due to a continuous program of product improvement, Avtec reserves the right to make changes in design and specifications without prior notice.

NOTICE: Please read the entire manual carefully before installation. If certain recommended procedures are not followed, warranty claims will be denied.

Product Information MODEL NUMBER:

SERIAL NUMBER:

INSTALLATION DATE:

Regulatory Information

UL Avtec VSP Hoods
UL File number – MH12966

Southern Pride Smoker
UL File number – MH11943

Verification of these UL file numbers can be found at www.ul.com. Go to the certifications tab and type in the UL file number in the UL online certifications directory.

IMC The 2006 International Mechanical Code is referenced on the TTW VSP hood drawings.

506.3.12.3 Termination Location

Exhaust outlets shall be located not less than 10 feet (3048 mm) horizontally from parts of the same or contiguous buildings, adjacent buildings, adjacent property lines and air intake openings into any building and shall be located not less than 10 feet (3048 mm) above the adjoining grade level.

Exception

Exhaust outlets shall terminate not less than 5 feet (1524 mm) from parts of the same or contiguous building, an adjacent building, adjacent property line and air intake openings into a building where air from the exhaust outlet discharges away from such locations.

NFPA-96 These exhaust hoods are intended for use in accordance with the Standard of the National Fire Protection Association for the Ventilation Control and Fire Protection of Commercial Cooking Operations.

Option 1: Indoor Installation

HOOD SYSTEM TO INCLUDE:

1. VENTILATION HOOD
2. 2-SPEED FAN (1380CFM/2000CFM)
1/2 HP, 120/1/60, .75" STATIC PRESSURE
(DUCT RUNS WITH MORE THAN ONE ELBOW,
CONSULT FACTORY FOR FAN SIZE) FOR
WIRING, SEE ELECTRICAL CONNECTIONS ON
PAGE 11.
3. CURB INCLUDED WITH VENTED EXTENSION
AND HINGE KIT.

NOTES:

1. OPTIONAL PITCH SHOWN, FLAT CURBS ARE
STANDARD.
2. 120V/1/60 POWER STANDARD ON EXHAUST
FAN.
3. FAN SIZED FOR DUCT RUN WITH ONE
ELBOW.
4. FOR DUCT RUNS WITH MORE THAN ONE
ELBOW, CONSULT FACTORY FOR FAN SIZE.

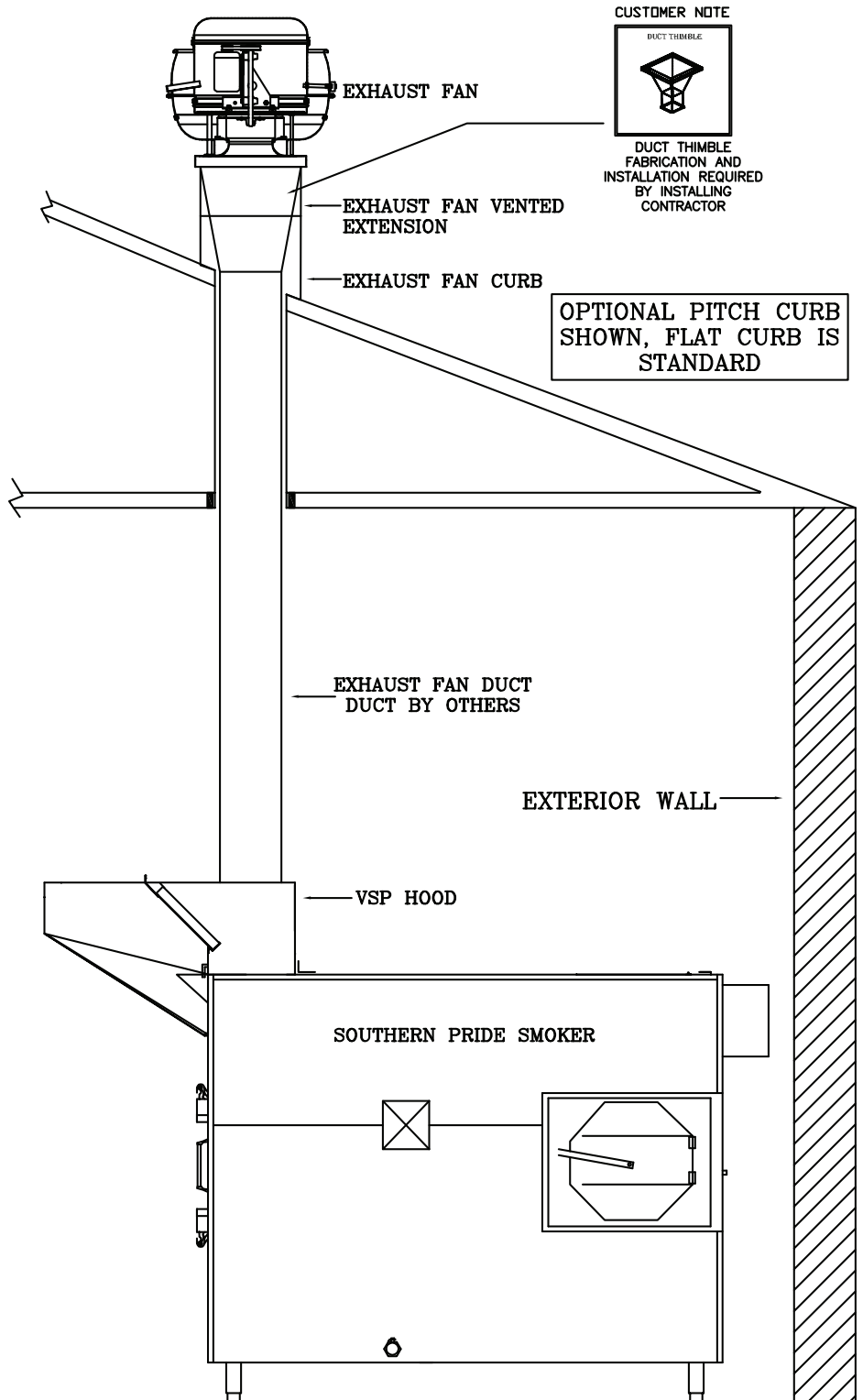

Option 2: Through the Wall Installation

HOOD SYSTEM TO INCLUDE:

1. VENTILATION HOOD
2. 2-SPEED FAN (1380CFM/2000CFM)
1/2 HP, 120/1/60, .75" STATIC PRESSURE
(DUCT RUNS WITH MORE THAN ONE ELBOW,
CONSULT FACTORY FOR FAN SIZE) FOR
WIRING, SEE ELECTRICAL CONNECTIONS ON
PAGE 11.
3. CURB INCLUDED WITH VENTED EXTENSION
AND HINGE KIT.

NOTES:

1. IMPORTANT SMOKER NOTE: WHEN
INSTALLING AN OVEN THROUGH A WALL
CONSTRUCTED OF COMBUSTIBLE
MATERIAL, PLEASE REFER TO UL LISTING
(MH11943) DURING INSTALLATION. OVEN
MAY BE INSTALLED THROUGH WALL WITH
ZERO CLEARANCE WHEN BBR KIT NO 2099
PROVIDED.
2. OPTIONAL STAINLESS STEEL TRIM KIT FOR
WALL INSTALLATION AVAILABLE FROM
SOUTHERN PRIDE.
3. OPTIONAL PITCH SHOWN, FLAT CURBS ARE
STANDARD.

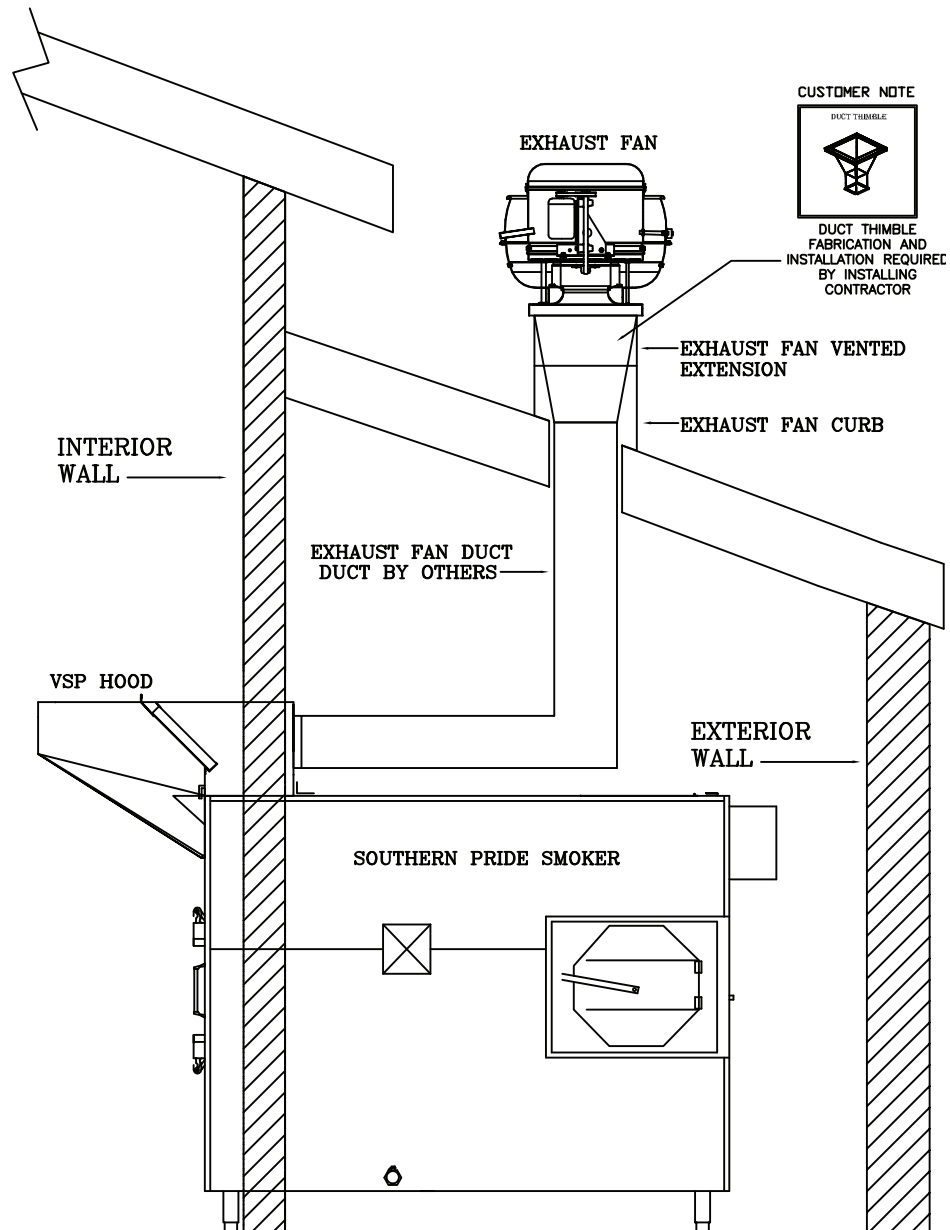

Option 3: Through the Wall Installation with Curb Assembly

International Mechanical Code

506.3.12.3 Termination Location Exception:

Exhaust outlets shall terminate not less than 5 feet (1524 mm) from parts of the same or contiguous building, an adjacent building, adjacent property line and air intake openings into a building where air from the exhaust outlet discharges away from such locations.

HOOD SYSTEM TO INCLUDE:

1. VENTILATION HOOD
2. 2-SPEED FAN (1380CFM/2000CFM)
1/2 HP, 120/1/60, .75" STATIC PRESSURE
(DUCT RUNS WITH MORE THAN ONE ELBOW,
CONSULT FACTORY FOR FAN SIZE) FOR
WIRING, SEE ELECTRICAL CONNECTIONS ON
PAGE 11.
3. VSP TILTED CURB ASSEMBLY INCLUDED.

NOTES:

1. IMPORTANT SMOKER NOTE: WHEN INSTALLING AN OVEN THROUGH A WALL CONSTRUCTED OF COMBUSTIBLE MATERIAL, PLEASE REFER TO UL LISTING (MH11943) DURING INSTALLATION. OVEN MAY BE INSTALLED THROUGH WALL WITH ZERO CLEARANCE WHEN BBR KIT NO 2099 PROVIDED.
2. OPTIONAL STAINLESS STEEL TRIM KIT FOR WALL INSTALLATION AVAILABLE FROM SOUTHERN PRIDE.
3. OPTIONAL PITCH SHOWN, FLAT CURBS ARE STANDARD.

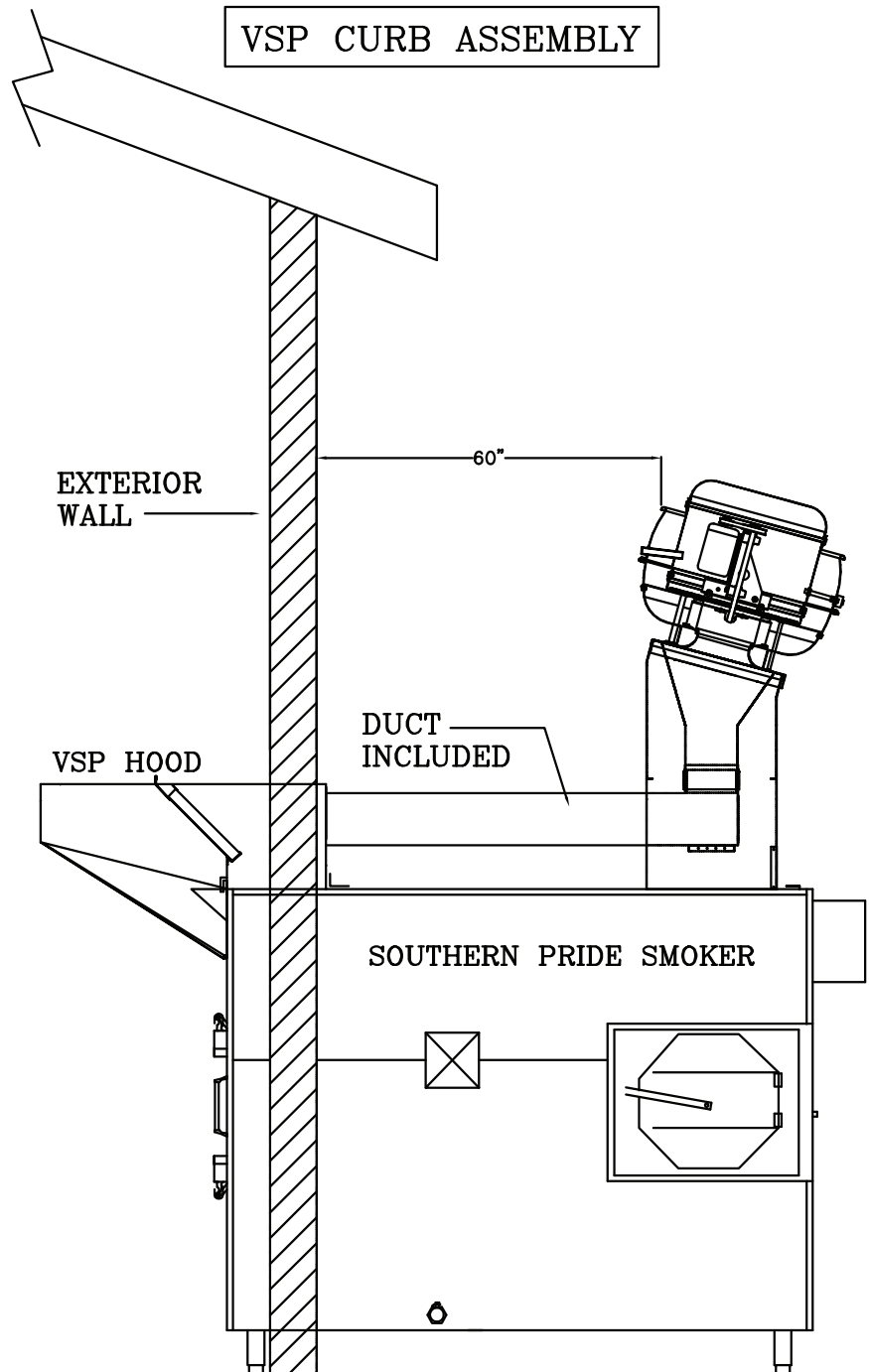

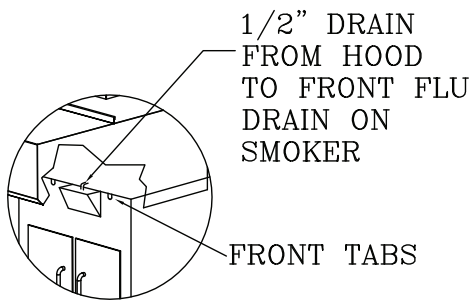

Figure 1

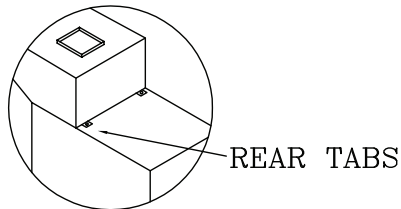

Figure 2

Avtec VSP's sit directly on the Southern Pride Smokers.

1. Check all local codes prior to installation. Special requirements may be necessary depending upon building material construction.
2. Move crated hood to location of installation and very carefully uncrate hood.
3. Raise hood up and sit on the Southern Pride Smoker.
4. Line up hood so it is pushed all the way back so the front tabs of the hood will be secured to smoker oven. (See Figures 1 & 2)
5. Install with self-tapping stainless steel sheet metal screws.
6. Install grease filters into front of hood by sliding them into the filter channel built into the hood.

THE DRAIN CONNECTION IS DESIGNED TO FACILITATE CLEANING AND MUST BE DIRECTED TO FRONT FLUE ON SMOKER SO CONDENSATION DRAINS INTO FLUE.

Exhaust Fan & Duct: When 2-speed exhaust fan is installed correctly, it will operate at a low CFM when oven doors are closed, and a high CFM when doors are open.

1. Check all local codes prior to installation.
2. All exhaust fans are supplied with a minimum 18" high metal curb, hinge kit, and grease box.
3. The exhaust fan curb should be installed directly above the hood if possible. Always maintain the shortest duct run possible.
4. Cut hole and seal exhaust fan curb to roof.
5. Place exhaust fan on curb.
6. Install hinges on exhaust fan cap and metal curb. Remember to leave ample room for fan to tilt back. Fan will remain in tilted back position.
7. Install grease collection box on side of fan that has grease tube discharge.
8. The exhaust duct must be constructed of 16 gauge carbon steel or 18 gauge stainless steel. All seams must be fluid welded.
9. A duct transition should be provided below exhaust fan inlet.
10. The exhaust duct must be fluid welded to hood collar.
11. Make all necessary electrical connections and check fan for proper rotation.
NOTE: Fan will exhaust air running in wrong direction. Refer to page 11.

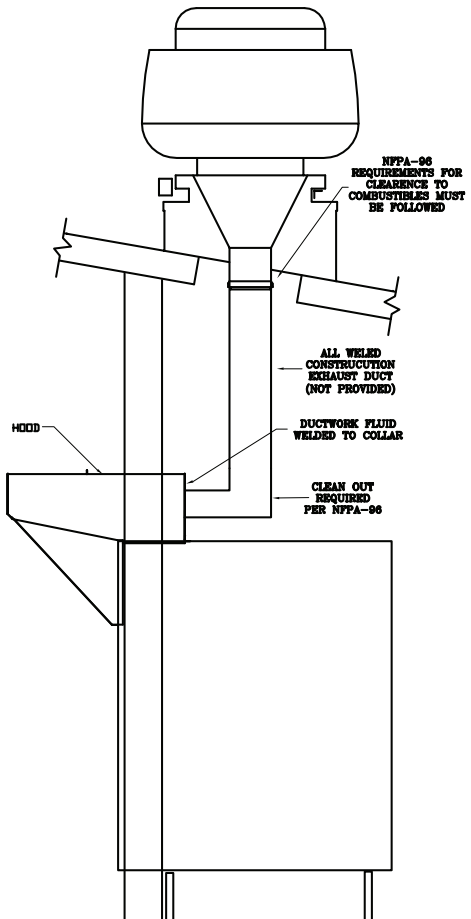
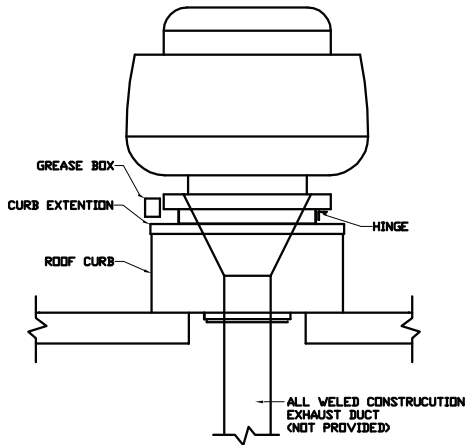

Installation Instructions

International Mechanical Code

506.3.12.3 Termination Location Exception:

Exhaust outlets shall terminate not less than 5 feet (1524 mm) from parts of the same or contiguous building, an adjacent building, adjacent property line and air intake openings into a building where air from the exhaust outlet discharges away from such locations.

1. Check all codes prior to installation.
2. The exhaust fan curb should be installed directly on top of smoker. Connect the exhaust duct to the hood collar. Secure duct with supplied nuts and bolts. (See Figure below)
3. Secure exhaust fan curb assembly to the top of the smoker. Drive screws through flange of curb assembly in to edge of smoker. ****Only along the back edge of the smoker.**** Two screws minimum. Holes may have to be predrilled through flange. (See Figure below)
4. Install hinge kit on curb assembly and exhaust fan. (Provided by fan manufacturer).
5. Install grease collection box on side of fan that has grease tube discharge.
6. Make all necessary electrical connections and check fan for proper rotation.
NOTE: Fan will exhaust air running in wrong direction. Refer to page 11.

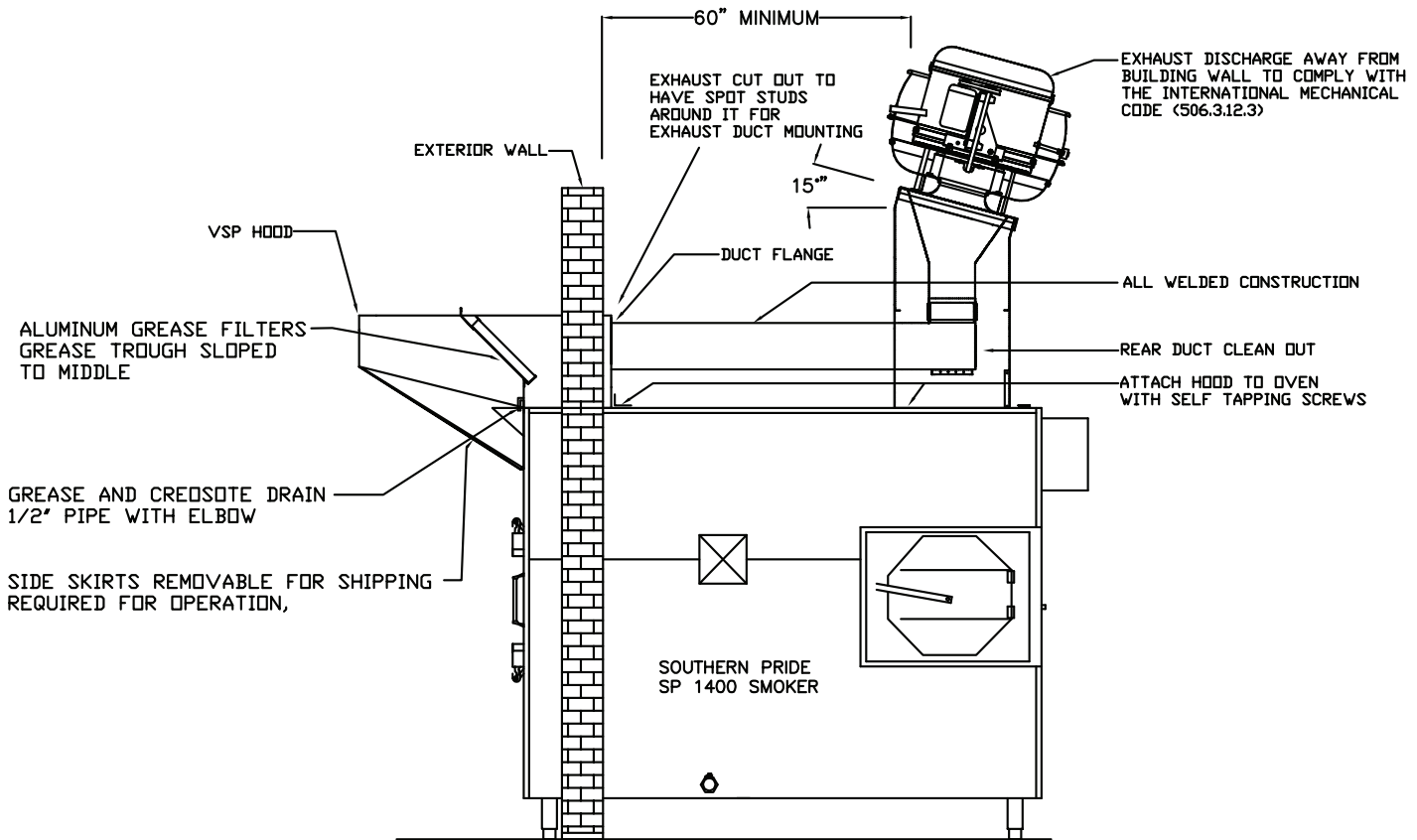

Electrical Connection for VSP Hood to 2-Speed Exhaust Fan

NOTICE: It is suggested that a 120V outlet on a 20 AMP breaker be supplied for oven and hood system.

When 2-speed exhaust fan is installed correctly, it will operate at a low CFM when oven doors are closed and a high CFM when doors are open.

Wiring for 120V/60C/1P 2-Speed Fan Application

SUPPLIED FROM OVEN:

Black – High Speed
Red – Low Speed
White – Neutral

SUPPLIED FROM FAN:

Black – High Speed
Red – Low Speed
White – Neutral

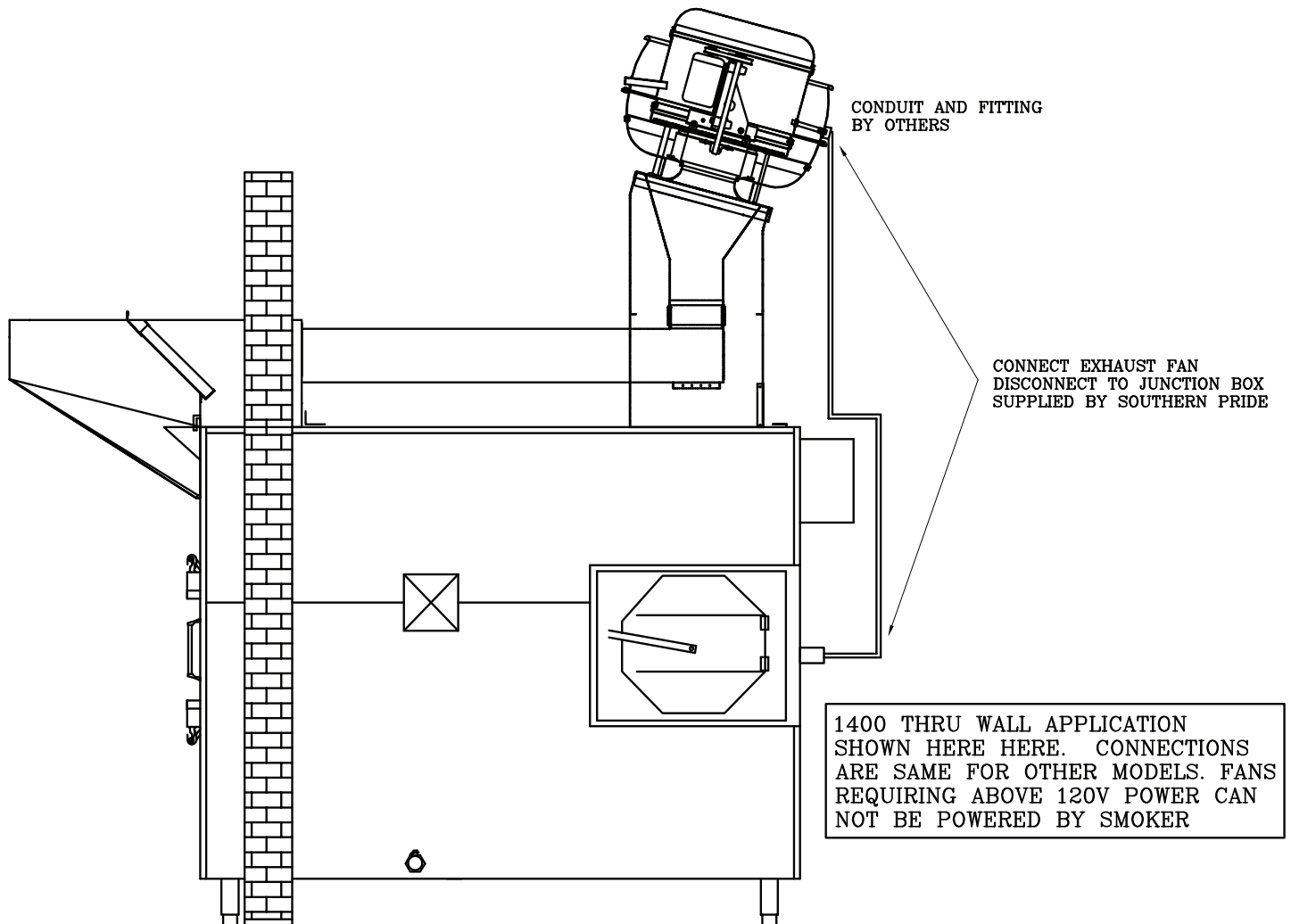

Warranty

Congratulations on your purchase of an Avtec brand piece of equipment. Unified Brands believes strongly in the products it builds and backs them with the best warranty in the industry. Standard with every unit comes the piece of mind that this unit has been thoroughly engineered, properly tested and manufactured to excruciating tolerances, by a manufacturer with over 30 years of industry presence. On top of that front end commitment, Unified Brands has a dedicated staff of certified technicians that monitor our own technical service hotline at 1-800-621-8560 to assist you with any questions or concerns that may arise after delivery of your new Avtec equipment.

- 1 year parts replacement of any and all parts that are found defective in material or workmanship
- 1 year labor reimbursement for any repairs that are caused by Avtec's use of defective material or workmanship (Repairs to be performed by an Avtec Authorized Service Agent (ASA) at contracted rate)
- Warranty begins at the time of installation or 6 months from factory shipment, whichever occurs first.

For warranty inquiries or questions regarding current ASAs please contact the Avtec technical support hotline at 1-800-621-8560 or visit the Avtec page of our web site at www.unifiedbrands.net.

Items Not Covered Under Warranty

- Maintenance type of repairs such as routine cleaning, temperature adjustments, air balancing, clogged drains, unit leveling, and gasket replacement or cleaning.
- Repairs caused by abuse, freight damage, improper or incomplete installation, accidents, unauthorized alterations, and local codes not previously brought to the attention of the Avtec engineering department.
- Component failure due to inadequate power supply, gas supply or water supply, and water damage from cleaning procedures.

Specification & Product Design

Due to continued product improvement, specification and product design may change without notice. Such revisions do not entitle the buyer to additions, changes or replacements for previously purchased equipment.

Sanitation Requirements

Certain areas require specific sanitation requirements other than N.S.F. & U.L. standards. Unified Brands must be advised of these specifications before fabrication of equipment. In these special circumstances, a revised quotation may be required to cover additional costs. Failure to notify Unified Brands before fabrication holds the dealer accountable for all additional charges.

Cancellations

Orders canceled prior to production scheduling entered into engineering/production and cancelled are subject to a cancellation charge (contact Customer Service for details).

Warranty

Storage Charges

Unified Brands makes every effort to consistently meet our customers' shipment expectations. If after the equipment has been fabricated, the customer requests delay in shipment, and warehousing is required:

- Equipment held for shipment at purchaser's request for a period 30 days beyond original delivery date specified will be invoiced and become immediately payable.
- Equipment held beyond 30 days after the original delivery date specified will also include storage charges.

Shipping & Delivery

Unified Brands will attempt to comply to any shipping, routing or carrier request designated by dealer, but reserves the right to ship merchandise via any responsible carrier at the time equipment is ready for shipment. Unified Brands will not be held responsible for any carrier rate charges when the Dealer's requested carrier is used. Rate charges are entirely between the carrier and purchaser. Point of shipping shall be determined by Unified Brands (Weidman, MI / Jackson, Mississippi). At Dealer's request, Unified Brands will endeavor whenever practical to meet dealers request. Freight charges for Dealer requested carriers will be collect unless otherwise noted.

Damages

All crating conforms to general motor carrier specifications. To avoid concealed damage, we recommend inspection of every carton upon receipt. In the event the item shows rough handling or visible damage, to minimize liability, a full inspection is necessary upon arrival. A notation must be placed on the freight bill and signed for by the truck driver. Appearance of damage will require removing the crate in the presence of the driver. Consignee is responsible for filing of freight claims when a clear delivery receipt is signed. Claims for damages must be filed immediately (within 10 days) by the consignee with the freight carrier. Retain all cartons and merchandise for inspection.

Returned Goods

Authorization for return must first be obtained from Unified Brands before returning any merchandise. Any returned goods shipment lacking the return authorization number will be refused, all additional freight costs to be borne by the returning party. Returned equipment must be shipped in original carton, freight prepaid and received in good conditions. Any returned merchandise is subject to a minimum handling charge (consult Customer Service for rate).

Installation

Equipment installation is the responsibility of the dealer and/or their customer.

Penalty Clauses

Dealer penalty clauses, on their purchase order or contractually agreed to between the dealer and their clients are not binding on Unified Brands. Unified Brands does not accept orders subject to penalty clauses. This agreement supersedes any such clauses in dealer purchase orders.

Export Policy

All quotations for export sales will be handled by Unified Brands export management organization. Contact Unified Brands customer support at 1-888-994-7636 for further details on export equipment.

Warranty

Warranty

Unified Brands warrants to the original purchaser for use of our products, that any part thereof which proves to be defective in material or workmanship under normal use within one year from date of installation, will be replaced free of charge. Labor to replace such parts is warranted for one year from installation. All warranty labor to be performed during regular working hours, with no overtime premium.

All warranty service must be authorized by the factory and be performed by AVTEC's authorized service personnel.

This warranty is limited to the United States and Canada.

This warranty does not apply to any damage resulting from shipping, improper installation, accident, unauthorized alteration, local codes not previously brought to the attention of AVTEC, misuse, or abuse; and does not cover loss of food, other products or damage to equipment or property resulting from mechanical or electrical failure.

AVTEC neither makes nor assumes and does not authorize any other person to assume any other obligation of liability in connection with its products other than that covered in this warranty.

Safety Procedures

- Do not attempt to service this unit yourself as removing covers may cause unnecessary exposure to dangerous voltage.
- Never connect the unit to a power source while standing in water. Wet hands and wet floors should be avoided when connecting any electrical appliance to a power outlet.
- Fans may have multiple power connections. Make sure all fans are isolated from power prior to performing maintenance.

Warranty Service Procedures

Please have the following information before calling one of the service contacts:

- Serial Number. If Serial Number is not available, please call the Unified Brands Service Department at 888-994-7636 ext. 2408 with the job site address. From this they may be able to get you the necessary reference numbers that our service department needs.
- Description of problem/service issue.
- Job site address, contact & phone number.

Contact Information

PLEASE CALL AVTEC SERVICE DEPARTMENT WITH ALL VSP SERVICE RELATED ISSUES!

Unified Brands/Avtec Parts & Service Department

Phone: 888-994-7636, Fax: 989-644-4222

Dan Wixson – Ext. 6469, E-Mail: dwixson@unifiedbrands.net

Brian Zingler – Ext. 6405, E-Mail: bzingler@unifiedbrands.net

Scott Sandel – Ext. 6442, E-Mail: scotts@unifiedbrands.net

Ventilation Maintenance Guide

Roof Top Systems- Make Up Air & Exhaust Fans

1. Air intake filters should be cleaned monthly or more often as conditions dictate.
2. Check all belts for slippage and tighten as necessary.
3. Clean exhaust fan interior and wheel as required to prevent accumulation of grease that could lead to a fire hazard.
4. Electrical connections should be inspected every six months.
5. Oil and/or grease all motors and bearings every six months.
6. If supplied, check and empty grease collection cup on outside of exhaust fan.

Cleaning and Maintenance of Stainless Steel Hoods

1. Carefully wipe away gritty substances clinging to hood surface to avoid scratching.
2. Dilute ½ cup EVAC detergent with 1 gallon warm water.
3. Soak a cloth in the water detergent solution, wring out excess.
4. Rub the cloth in the direction of the grain.
5. Wipe stainless steel dry with a clean cloth.
6. Reapply stainless steel polish.
7. Empty and clean grease drain and cups as needed per your application.
8. Filters should be cleaned in a dishwasher or soak sink as needed per your application.

CAUTIONS **DO NOT** use steel wool (Brillo Pads), scrapers, or spatulas to clean hood!

DO NOT use the following substances on or around the hood!

1. Chlorine or chlorine based substances.
2. Acids (e.g. mercuric chloride, ferric chloride).

Vapors of the above substances can corrode stainless steel!

Notes

Notes

Notes



1055 Mendell Davis Drive • Jackson MS 39272
888-994-7636 • 601-372-3903 • Fax 888-864-7636
unifiedbrands.net