

INSTRUCTION MANUAL

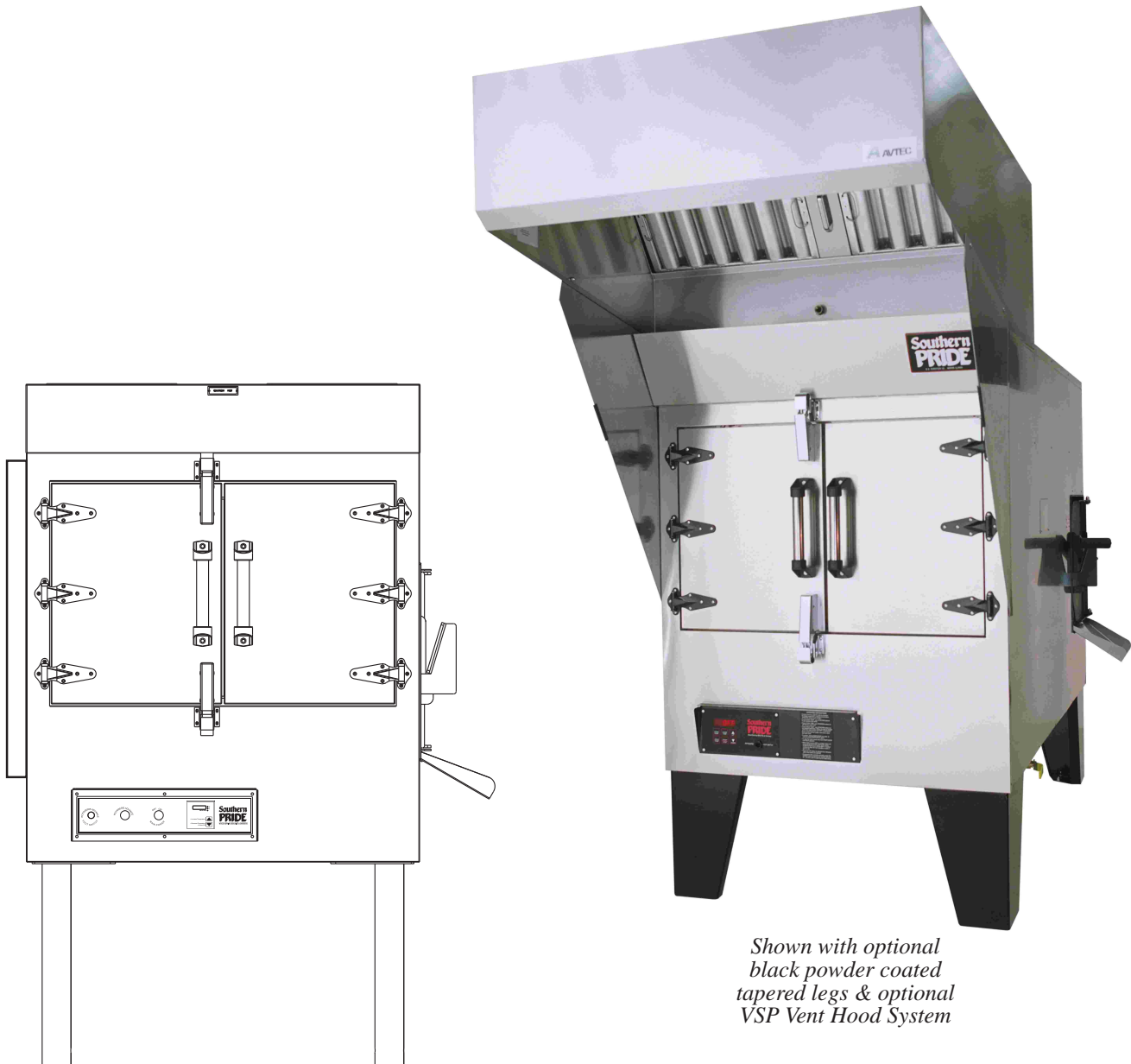

*Shown with optional
black powder coated
tapered legs & optional
VSP Vent Hood System*

CONGRATULATIONS

In selecting Southern Pride, you have chosen the finest, most advanced and most fully automatic wood burning barbecue pit available. With us, “It’s Simply, a Matter of Pride”.

Please read this Instruction Manual carefully prior to installation and operation of your Southern Pride pit. Proper installation, operation, cleaning, and maintenance are essential for your satisfaction and safe operation.

KEEP THIS MANNUAL FOR REFERENCE

TABLE OF CONTENTS

Safety Information	3
Diagram of Controls & Components	4
Operating Instructions	6
Cold Weather Operations/Mobile oven note	11
Cleaning Instructions	12
Maintenance Schedule	14
Electrical Instructions	16
Burner Specification & Instructions	20
Gas Piping Instructions	21
Venting Instructions	22
Replacement Parts List	24
Warranty	25

SAFETY INFORMATION

FOR YOUR SAFETY

IF YOU SMELL GAS . . .

1. Open Windows.
2. Do not touch electrical switches.
3. Extinguish any open flames.
4. Immediately call your gas supplier.

DO NOT STORE OR USE GASOLINE OR OTHER FLAMMABLE VAPORS OR LIQUIDS IN THE VICINITY OF THIS OR ANY OTHER APPLIANCES.

1. The pit area **MUST** be kept clear and free of combustible materials, gasoline and other flammable vapors and liquids.
2. The flow of combustion and ventilating air **MUST NOT** be obstructed from reaching the pit.
3. The frame of the unit **MUST** be electrically grounded at all times. See “Electrical instructions”.
4. Caution should be used when opening and closing the Firebox Door. The door is **HOT** during operation.
5. **DO NOT** remove service compartment access panels when unit is in operation or leave off during operation.
6. Gas burners require the services of an experienced mechanic for proper setting and adjustment. If the burner does not appear to be operating properly, **DO NOT ATTEMPT TO ADJUST THE BURNER YOURSELF**, but call in a competent serviceman or contact Southern Pride.
7. **DO NOT** allow unqualified personnel to perform service work or adjustments on this unit. To do so, will **VOID WARRANTY** and could result in a hazardous condition.
8. Be sure any new employees, who might operate the unit, are instructed on operation and safety information prior to operating the unit.
9. Caution: Ashes removed from the Firebox should be stored in a non-combustible container with a sealed lid only. Store ashes in a well ventilated area. **FUMES COULD BE HAZARDOUS.**
10. **WARNING: IT IS EXTREMELY IMPORTANT TO FOLLOW DAILY CLEANING INSTRUCTIONS. GREASE OR SOLIDS BUILDUP INSIDE THE PIT COULD RESULT IN A FIRE HAZARD.**
11. **KEEP THIS INSTRUCTION MANUAL FOR REFERENCE.**

SOUTHERN PRIDE'S SPX-300 BBQ OVEN

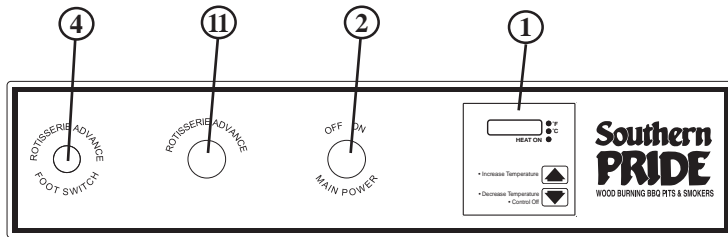
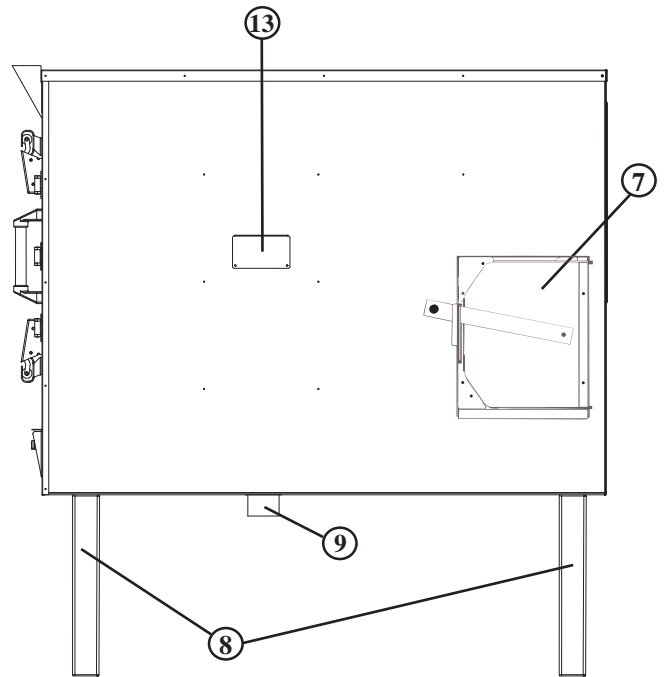
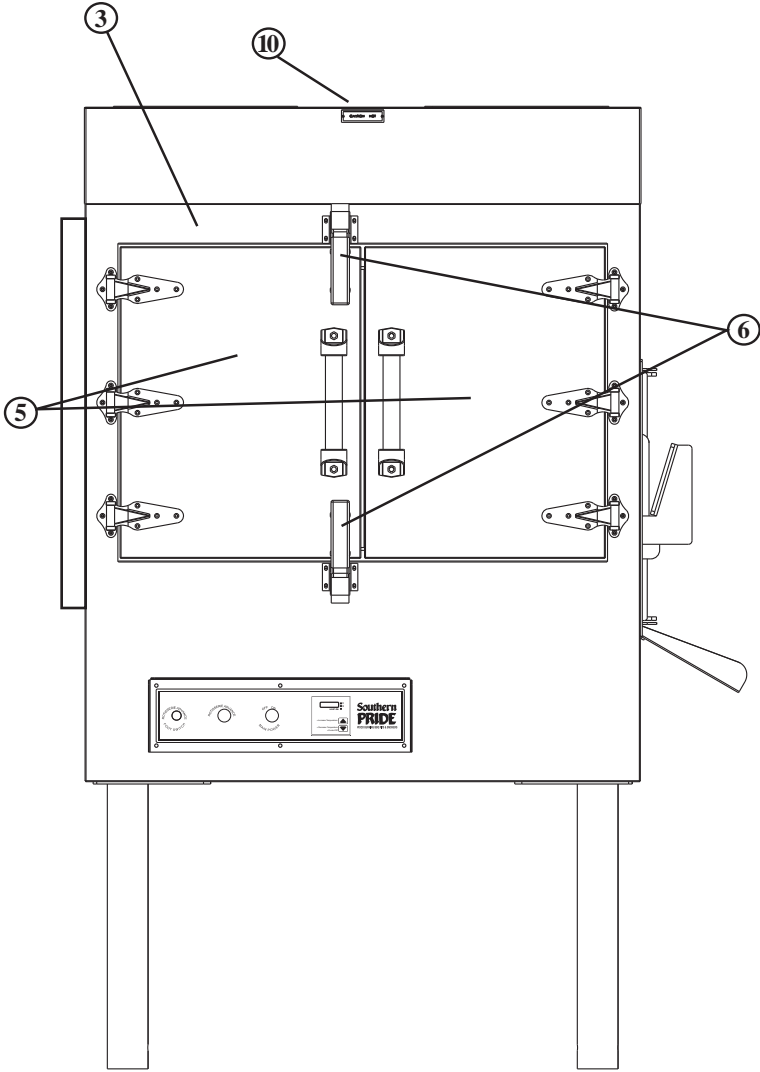

Standard Controls

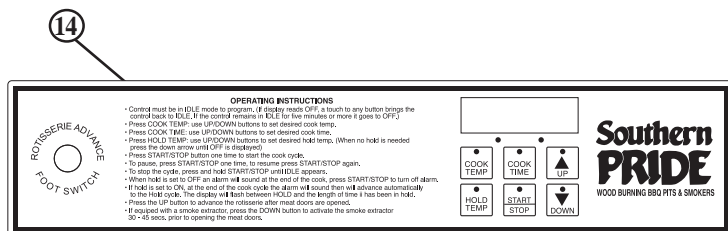

Optional Digital Controls

SPX-300 CONTROLS AND COMPONENTS

1. **CV CONTROL THERMOSTAT** - Adjustable temperature setting (140-325° F) with OFF position. Maintains desired Pit temperature by controlling the Gas Burner. It also displays the actual temperature inside the oven during the cook cycle.
2. **MAIN POWER SWITCH** - Activates the Rotisserie, Convection Fan, Thermostat, and Red Indicator Lamp. (The Red Indicator Lamp on the Main Power Switch indicates when the switch is ON.)
3. **DOOR INTERLOCK SWITCH** - When doors are opened, the Rotisserie, Convection Fan and Gas Burner are automatically turned off. On ovens with an optional Smoke Extractor the Smoke Extractor is automatically activated. On ovens with optional VSP Vent Hood Systems the exhaust fan is automatically switched to high speed.
4. **ROTISSERIE ADVANCE FOOT SWITCH** - activates the rotisserie when foot switch is depressed.
5. **MEAT LOADING DOORS** - For access to Racks and Pit interior.
6. **MEAT LOADING DOOR LATCHES** - Latches apply positive pressure and seals doors.
7. **FIREBOX DOOR** - Provides access for loading of wood in the Firebox Chamber.
8. **CABINET LEGS** - Provides adjustment for leveling of the unit.
9. **DRAIN VALVE** - Is opened after each cooking to drain grease.
10. **FLUE COLLAR** -For connection of 6” Flue.
11. **ROTISSERIE ADVANCE SWITCH** - Momentarily activates Rotisserie to advance the food racks for loading and unloading when the Meat Door is open, or the Main Power switch is OFF.
12. **CONVECTION FAN** - Provides air flow inside the Oven for even cooking.
13. **BEARING COVER** - Provides access for Bearing replacement.
14. **DIGITAL CONTROL (Optional)** - Provides precise control of the oven and adds special features, such as a Hold Mode, Automatic Cool Down prior to advancing into the Hold Mode and an Audible Alarm that sounds when the Cook Cycle is complete or when the control advances to the Hold Mode.

OPERATING INSTRUCTIONS

1. Load meat on the food racks. **DO NOT LET THE MEAT EXTEND BEYOND OR HANG OVER THE EDGE OF THE RACKS.**



CORRECT
Load meat on bottom rack first.



INCORRECT
May cause food to tip and meat to fall.
This could cause the Rotisserie to jam.

2. To advance the racks with the Meat Doors open, depress the Red Rotisserie Advance Button on ovens with standard controls, (On digital controls, press the UP arrow button) or step on the rotisserie advance foot pedal until the racks advance to the next position.
3. After the meat is loaded, depress the Red Rotisserie Advance Button on ovens with standard controls, (On digital controls press the UP arrow button) or step on the rotisserie advance foot pedal and allow the rotisserie to make one complete revolution. Check meat clearances to cabinet and all racks. If necessary reposition the meat on the racks for maximum clearances.
4. Open the Fire Box door and slide the ash scoop out to remove any ashes or log pieces that might be there from the previous cook. Dump the ashes into a metal air tight ash container. Use heat proof gloves if the ash scoop has hot ashes in it.



5. Put a small amount of wood in the Firebox. Use 1-2 logs, 4-6 inches in diameter, 12-15 inches long. Use green or slightly seasoned hardwoods, fruitwoods, or charcoal. Be sure to keep the wood 6" from the burner or ashes can accumulate on the burner and cause it to not work properly. Lay the logs on top of each other at different angles to ensure good air flow around each log.



Correct way to load wood.

CAUTION

DO NOT USE DRY WOOD OR KINDLING.

DO NOT OVERLOAD FIREBOX. TOO MUCH WOOD CAN CAUSE OVERHEATING OF THE PIT.

COALS AND ASHES FROM PREVIOUS COOKING MUST BE REMOVED BEFORE LOADING WOOD.

DO NOT ALLOW ASHES IN OR NEAR THE BURNER OPENING. KEEP ALL LOGS AT LEAST 6 INCHES FROM THE BURNER.

6. Be sure Firebox Door and Meat Loading Door Latches and drain valve are secured in the closed position.
7. To start the cook cycle refer to the next section “How to Program a Menu” depending on which type of controller you have.

8. To check or unload meat, on units with optional Smoke Extractor; open the meat doors just enough to activate the Smoke Extractor, for approximately 20 seconds prior to fully opening the Meat Loading Doors.
9. When the meat is cooked; on digital control models press and hold the start / stop button until idle appears in the LED, or on ovens with standard controls turn the Main Power Switch to the **OFF** position. On models with optional Smoke Extractor, with digital controls, press the down button to activate the smoke extractor, or on units with standard controls, open the meat doors enough to turn it on, wait for 20 seconds prior to fully opening the Meat Loading Doors. To unload racks, on ovens with digital controls press the up button to advance the rotisserie, or on an oven with standard controls depress the Rotisserie Advance Button or on either control types use the pneumatic foot pedal to advance the rotisserie until the racks advance to an unloading position.
10. After each cooking, remove the remaining wood and hot coals from Firebox, then open Drain Valve and drain grease while the pit is still warm. See step 4.

CAUTION: BE SURE MEAT LOADING DOORS AND FIREBOX DOOR ARE SECURED IN THE CLOSED POSITION IMMEDIATELY FOLLOWING A COOKING AND DURING NON-USE PERIODS.

WARNING: DO NOT OPEN DRAIN VALVE WHILE PIT IS STILL IN OPERATION OR WHILE BURNING WOOD AND HOT COALS ARE STILL IN FIREBOX.



IMPORTANT

The Gas Burner is equipped with an automatic ignition system. To ignite; on ovens equipped with digital controls press the start / stop button one time to start a menu, or on ovens with standard controls turn the Main Power Switch to the **ON** position and set Thermostat to desired temperature. To shut the Burner **OFF**, on ovens with digital controls press and hold the start stop button until idle is displayed in the LED or on standard control ovens, press the down button on the control until the LED displays “OFF”.

Programming a Menu with Standard Controls

- After the product has been loaded into the oven and the meat loading doors have been closed, and logs placed in the firebox and the firebox door closed and the drain valve is closed, turn the oven power switch on. The thermostat control on the oven will either come on to the last temperature used or be off.
- Using the up/down button on the controller set the desired temperature setting. Once the oven starts the LED display will show the actual internal temperature of the oven, you can toggle to the set temperature by pressing either up/down button.

NOTE: the controller does not control the length of the cook, it will run until it is turned off so the user must keep track of the time.

- At the end of the cook cycle press the DOWN button of the control until “OFF” is displayed in the LED display to turn off the burner.

Programming a Menu with Optional Digital Controls

The menu consists of a cook temperature, cook time, and choice of having the control advance to a hold mode after the cook time has elapsed or end the menu when the cook time has elapsed.

- Control must be in the “IDLE” mode, if the control is “OFF” a press of any button will bring the control back to “IDLE”.
- PRESS the cook temp button, (tEnP 1 will appear in the LED display): PRESS the up/down buttons to obtain the desired cook temperature.
- PRESS the cook time button, (tinE1 will appear in the LED display): PRESS the up/down buttons to obtain the desired cook time.
- Press the hold temp. button, (HtEnp will appear in the LED display): PRESS the up/down buttons to obtain the desired hold temp., if a hold temp. is not desired: PRESS the down button until “OFF” is displayed in the LED.
- Programming the menu is complete: To start the menu, PRESS the start/stop button one time. The control will begin the menu.
- To pause the menu PRESS the start/stop button one time, to resume the menu, PRESS the start/stop button again.
- To cancel or stop the menu, PRESS and hold the start/stop button until “IDLE” is displayed in the LED.

When the cook cycle is complete there are two possible actions that can be taken. One is if a hold temperature was programmed into the menu, the control will momentarily sound an audible alarm, (if equipped) the smoke extractor will be automatically activated, for a period of five mins, to bring the oven temperature down closer to the programmed hold temperature. Then, “HOLD” and the length of time the control has been in the hold mode will alternately flash in the LED display. The control will maintain the hold temperature until the start/stop button is depressed to “END” the menu, and bring the control to the “IDLE” mode. If the hold temperature was programmed to “OFF” then “END” will be displayed on the LED display, and an audible alarm will sound continuously until the start/stop button is depressed, to “END” the menu, and bring the control to the “IDLE” mode.

Programming a Menu with Optional Digital Controls Cont.

- The control should be in the “IDLE” mode. (The burner, convection fan, and the rotisserie will be off)
- When the menu is in progress a PRESS of the down arrow button will activate the smoke extractor (if equipped with the optional Smoke Extractor, prior to opening the meat doors, if the doors are not opened the smoke extractor will go off after one minute and the menu will resume. If the doors are opened the menu will resume when the doors are closed. The smoke extractor will automatically activate when the doors are opened, and the menu will resume again when the doors are closed.
- When the doors are open a PRESS of the up arrow button will advance the rotisserie or a PRESS of the foot pedal will advance the rotisserie when the meat doors are open too.
- Unload the meat from the racks, using the rotisserie advance button to rotate the racks.
- After each cook cycle, remove the remaining wood and coals from the firebox, then open the drain valve and drain the grease while the oven is still warm.
- After the control has been in the “IDLE” mode for five minutes it will go to “OFF”, a PRESS of any button will bring the control back to “IDLE”.

CAUTION: BE SURE THE MEAT LOADING DOORS AND THE FIREBOX DOOR ARE SECURED IN THE CLOSED POSITION IMMEDIATELY FOLLOWING A COOKING, AND DURING NON-USE PERIODS.

WARNING: DO NOT OPEN DRAIN VALVE WHILE PIT IS STILL IN OPERATION, OR WHILE BURNING WOOD AND HOT COALS ARE STILL IN THE FIREBOX.



SMOKER OVEN COLD WEATHER OPERATIONS

When temperatures drop below freezing there are issues that may develop. Listed below are some of those issues and ways to correct or reduce the effects of the problem.

1. Grease in oven drain solidifies in cold weather. Listed below are things that can be done to reduce, or correct the effects of this problem.
 - a. Drain the oven after every cooking to purge the drainpipe of liquids before they solidify. In extreme cold weather conditions customers have had success wrapping the drainpipe with electric heat tape and insulating heat tape and pipe.

 2. LED Displays an error 7
 - a. Ovens with digital cook and hold controllers are effected by cold weather particularly when the oven is outside or when it is a through the wall installation. This error typically only happens when the oven has not been used for a significant duration of time that allowed the oven to become extremely cold usually temperatures below 32°F. The following action will generally clear the error 7 code
 - b. Hold a cloth under warm water and wring water out, hold warm rag against top of thermocouple on the inside of oven for about 20-30 seconds. Remove rag and close door and start oven
-

NOTES FOR MOBILE OVENS

1. Ashes must be removed from the fire box prior to transport. Ashes can blow around inside the fire box when the oven is being towed and clog the burner causing it to not work properly.
2. Inspect the hanger locks and keys to ensure the rack hangers are locked prior to transport.
3. The ash chute is removable and could fall off if the fire box door is not properly secured. Prior to transport check the fire box door and chute or remove the chute prior to transport.

CLEANING INSTRUCTIONS

1. Remove ashes and coals from Firebox after each cook cycle.

Ash Disposal: Ashes should be placed in a non-combustible container with a tight fitting lid. The closed container of ashes should be placed on a non-combustible floor well away from all combustible material, pending final disposal.

Pull out the ash scoop from under the fire grate to remove all the ashes and coals from the Firebox.

Note: Ashes must be removed from the fire box on a mobile smoker prior to transport.



CAUTION: Fumes could be hazardous.

2. Drain grease. (Be sure hot coals and wood are removed from the Firebox before opening drain valve.)

Open Drain Valve and drain Grease.



3. Remove food racks and clean thoroughly. (Racks simply lift out of the brackets on the hangers.) To remove food rack hangers, lift hanger and pull straight back over Rotisserie Wheel Stubs.
4. Thoroughly clean complete interior of pit. Use food service degreaser. Spray degreaser on the interior of the pit and allow to set for 5-10 minutes. Rinse thoroughly with water hose or pressure washer. Drain through Drain Valve. Follow the Degreaser Manufacturer instructions and wear protective gear as needed. Do not spray water into the door interlock switch or the control panel. Putting a piece of duct tape over the door interlock switch will help make sure that no water gets into it.

WARNING

IT IS EXTREMELY IMPORTANT TO FOLLOW THE ABOVE **DAILY CLEANING PROCEDURES**. GREASE OR SOLIDS BUILDUP INSIDE THE PIT COULD RESULT IN A **FIRE HAZARD**.

Meat Door Latch Removal Instructions

The meat door latches are removable for cleaning.

To Remove:

1. Make sure your BBQ oven is off and has had time to cool down then open meat doors.
2. **CAUTION:** The latch rollers are spring-loaded and will spring open quickly with a lot of force, don't pinch a finger or hand. Un-cock or Release the latch roller by pushing up on the roller. See Photo 1.
3. Next use a screwdriver to pop the meat door latch loose from the oven, see photo 2.
4. Once the latch is off, clean it, inside and out as well as the meat door front, using conventional cleaners.
5. To Re-install the latch: Position it over the latch backing plate as per the photo 3 and slide top of latch assembly over the backing plate tabs.
6. Next using the palm of your hand or a rubber mallet tap the bottom of the latch, until it locks back onto the retaining tabs as per the photo 4.
7. **CAUTION:** The latch rollers are spring-loaded and will spring open quickly with a lot of force, don't pinch a finger or hand. You are now ready to cock the latch roller. Cock the latch roller by pushing down on it until it is set in the fully open position. Make sure latch roller is fully cocked before you release it. Photo 5.



photo 1



photo 2



photo 3

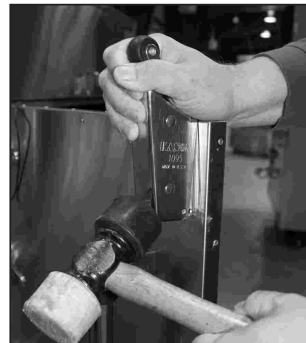

photo 4



photo 5

MAINTENANCE SCHEDULE

When washing the unit, Protect the Door Interlock Switch from getting wet.

AFTER EACH USE: Drain Grease and empty ashes from the firebox.

DAILY: Remove and clean all of the food racks. Thoroughly clean the complete interior of the oven, using a food service degreaser (follow instructions on degreaser) and rinse with a water hose or pressure washer. Drain through the drain valve.

WEEKLY:

1. Inspect Burner Head for accumulation of ashes and creosote. Clean as needed.
2. Inspect Convection Fan Blade for buildup of solids, or out of balance condition. Clean or replace as needed.
3. Inspect meat Loading and Firebox Door Gaskets. Replace if damaged or leaking.
4. Inspect Smoke Extractor Louver to be sure it closes completely. Clean or repair as needed. (If equipped with the optional Smoke Extractor)
5. Inspect the Interlock Switch to be sure the Plunger and Roller move freely. Lubricate with WD-40 or equivalent as needed.

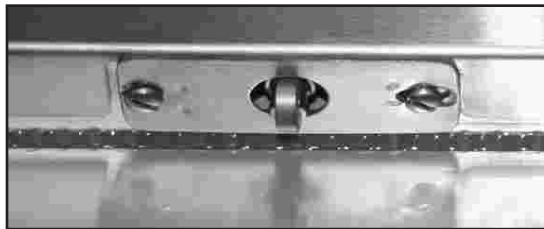

INSIDE
DOOR
FRAME

BI-MONTHLY INTERVAL

1. For Direct Vented ovens with a Smoke Extractor, the Smoke Extractor Damper and chimney should be inspected at least twice monthly for creosote buildup.
2. The Flue Pipe should be carefully inspected. Remove any solids buildup that has accumulated.

Creosote - Formation and need for removal:

When wood is burned slowly, it produces tar and other organic vapors, which combine with expelled moisture to form creosote. The creosote vapors condense in the relatively cool chimney flue of a slow burning fire. As a result, creosote residue accumulates on the flue lining. When ignited, this creosote makes an extremely hot fire.

IF CREOSOTE HAS ACCUMULATED IT SHOULD BE REMOVED TO REDUCE THE RISK OF A CHIMNEY FIRE.

ANNUALLY

Drive Chain lubrication instructions

1. To lubricate the Drive Chain, disconnect the power supply to the oven and remove the Drive Cover.
2. Use only quality SAE 20 oil for lubricating the Drive Chain.
3. The drive chain for the OT-300 Oven should be lubricated once each year.
4. Use a clean brush to apply oil to the slack side of the Drive Chain.

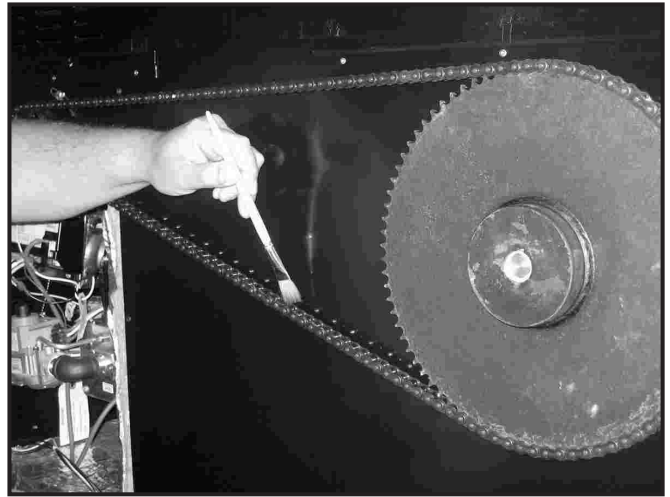
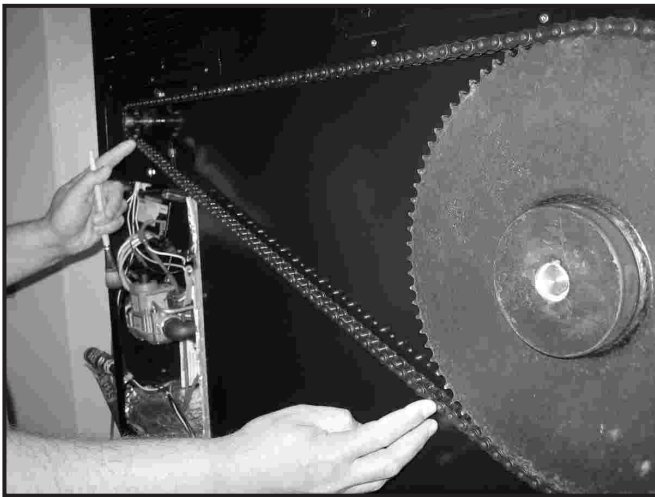

ELECTRICAL INSTRUCTIONS

ELECTRICAL REQUIREMENTS:

120 Volts A.C., 60 hz.,
2 wire, single phase,
15 amp wiring required.

WARNING:

**CHASSIS MUST BE GROUNDED TO
PREVENT POSSIBLE SHOCK HAZARD.
DO NOT ASSUME A PLUMBING LINE
WILL PROVIDE SUCH A GROUND.**

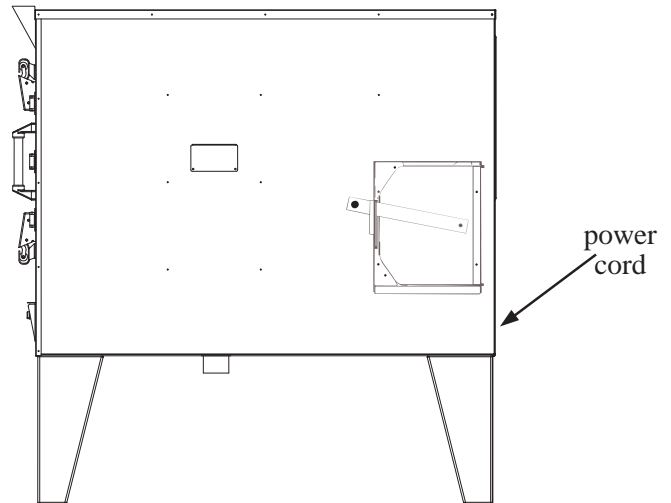

WARRANTY IS VOID IF UNIT IS CONNECTED TO ANY VOLTAGE OTHER THAN SPECIFIED ABOVE AND ON NAMEPLATE.

1. Electrician must provide the conduit and wire for hookup.
2. Power is to be left **OFF** throughout installation.
3. Electrical Service is connected via the factory supplied power cord located on the left front corner of the oven.

4. On models with optional Smoke Extractor, electrician must provide conduit and wire for hookup from Junction Box above the Smoke Extractor Motor on the top of the pit to the Exhaust fan. Make electrical connections inside the Junction box.

NOTE: THIS IS NOT A POWER SUPPLY CONNECTION. IT IS FOR A FAN CONNECTION ONLY.

**NOTE: 125 V.A.C., 1/4 hp
maximum connected load,
1100 cfm fan rating recom-
mended.**

5. If venting or gas connections are to be done later, be sure that power is **OFF**.

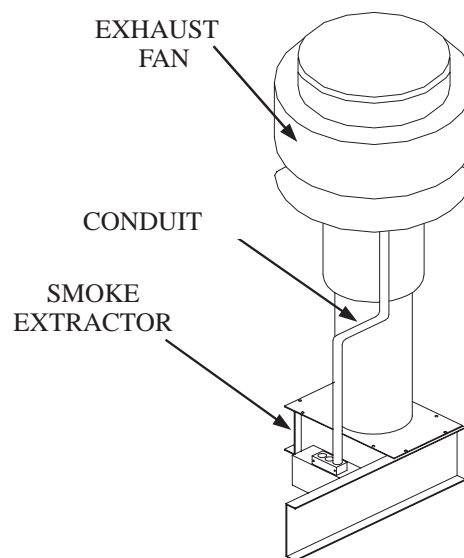

SPX-300 gas oven wiring diagram with Standard Controls

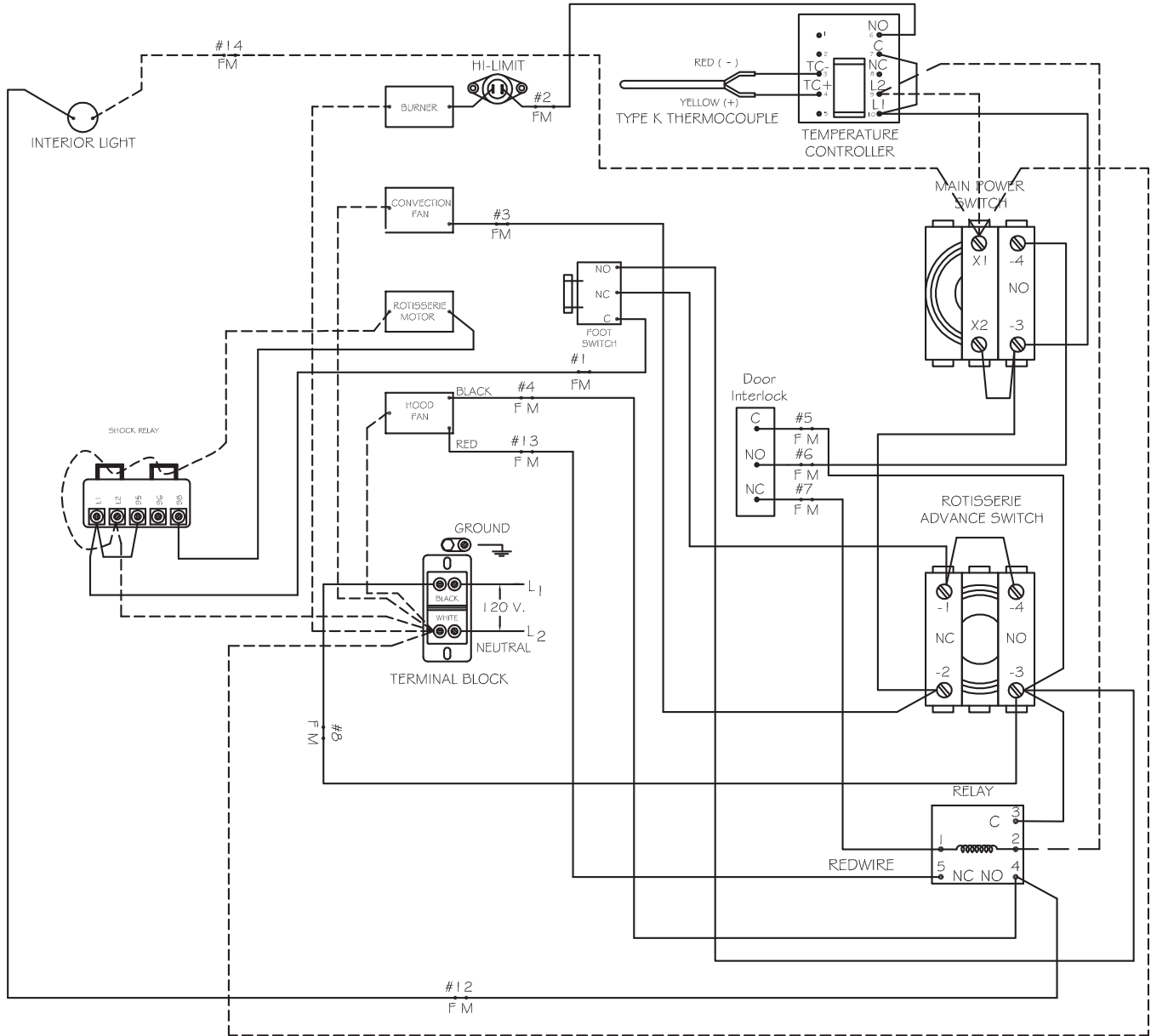

F=FEMALE END ON THE OVEN PLUG

15	14	13	12	11
10	9	8	7	6
5	4	3	2	1

M=MALE END ON THE CONTROL PANEL PLUG

5	4	3	2	1
10	9	8	7	6
15	14	13	12	11

NOTE: IF USING THE OPTIONAL VSP HOOD TO VENT THE OVEN, THEN THE OVEN SHOULD BE PLUGGED INTO A SWITCHED RECEPTACLE TO BE ABLE TO SHUT OFF THE HOOD.

SPX-300 gas oven wiring diagram with Digital Roast and Hold Controls

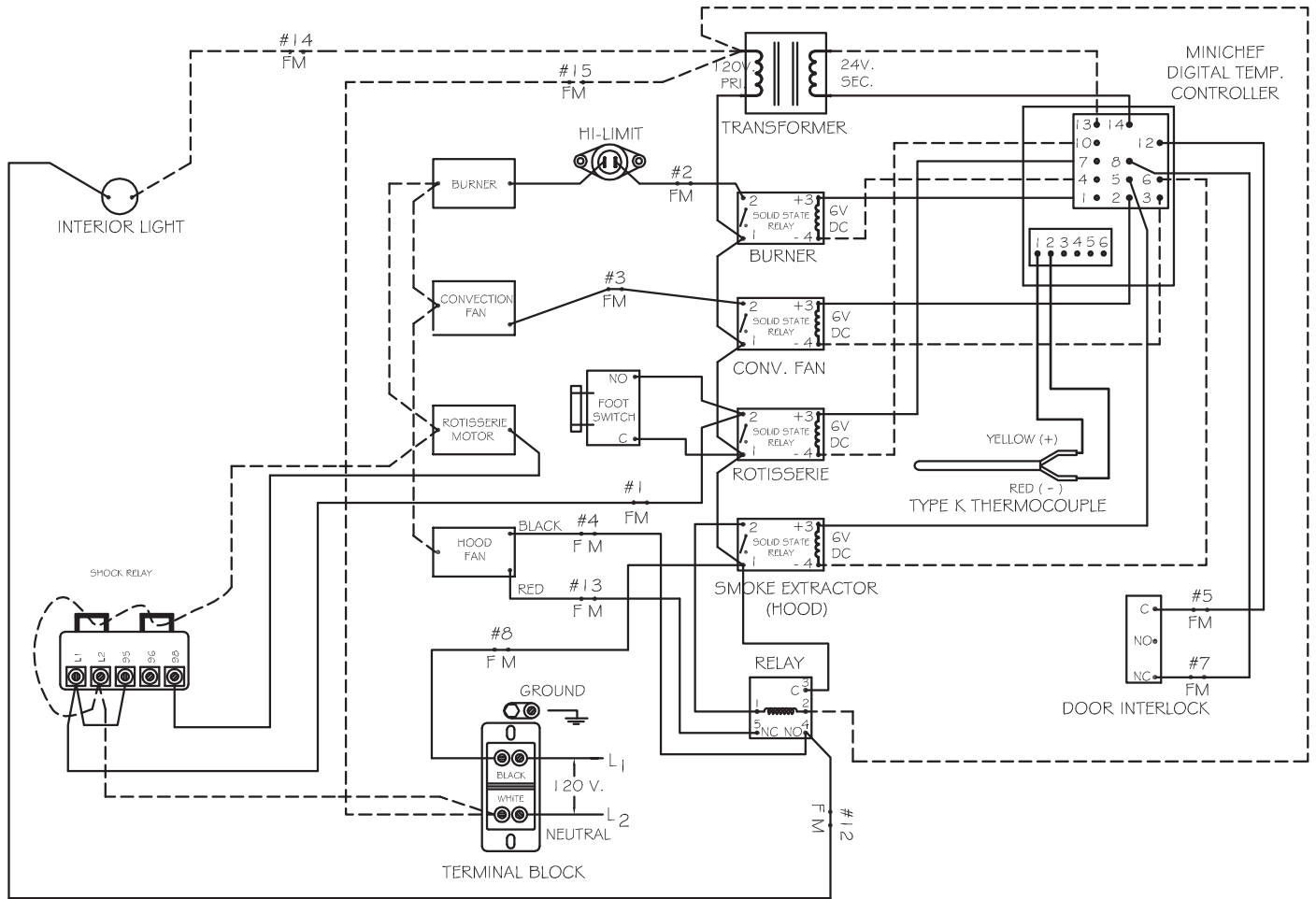

M=MALE END ON THE CONTROL PANEL PLUG

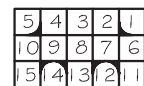

NOTE: IF USING THE OPTIONAL VSP HOOD TO VENT THE OVEN,
THEN THE OVEN SHOULD BE PLUGGED INTO A SWITCHED
RECEPTACLE TO BE ABLE TO SHUT OFF THE HOOD.

F=FEMALE END ON THE OVEN PLUG



ITEMS TO CHECK BEFORE FIRING BURNER

IMPORTANT

**WARNING: IMPROPER GAS HOOKUP WILL VOID WARRANTY
AND COULD RESULT IN A HAZARDOUS CONDITION.**

1. Gas line **MUST** be installed by a competent technician and in accordance with this Manual.
2. Gas line **MUST** include an easily accessible manual shutoff valve, drip leg, and pressure gauge port.
3. Gas pipe size **MUST** be in accordance with the Pipe Capacity Chart in this Manual.
4. Gas line **MUST** be tested for leaks under pressure.
5. Gas Line **MUST** be purged to remove any air in the system.
6. Gas line pressure **MUST** be checked and **MUST NOT** exceed the maximum pressure specified in the Burner Specifications in this Manual.
7. Burner Orifice **MUST** correlate with the type of gas being supplied, as specified in the Burner Specifications in this Manual.

BURNER SPECIFICATIONS

Burner Model: Wayne P250-EP

Firing Capacity: Maximum Input 50,000 BTU/HR, on Model SPX-300

Fuels: Natural and L.P. Gases

Electrical: 120 V.A.C., 60 hz, 1 ph

Orifice Sizes: Model SPX-300

Natural Gas - #30 (.129)

L.P. Gas - #45 (.082)

NOTE: Orifice and valve setting must correlate with type of gas being supplied.

Gas Supply Line Pressure: Natural - 4.5" W.C. Minimum 10.0" W.C Maximum L.P. - 11.0" W.C. Minimum 13.0" W.C. Maximum

MANIFOLD PRESSURE: Natural - 3.5" W.C. L.P. - 10.0" W.C.

GAS VALVE: Control Knob must be ON.

WIRING DIAGRAM FOR GAS BURNER

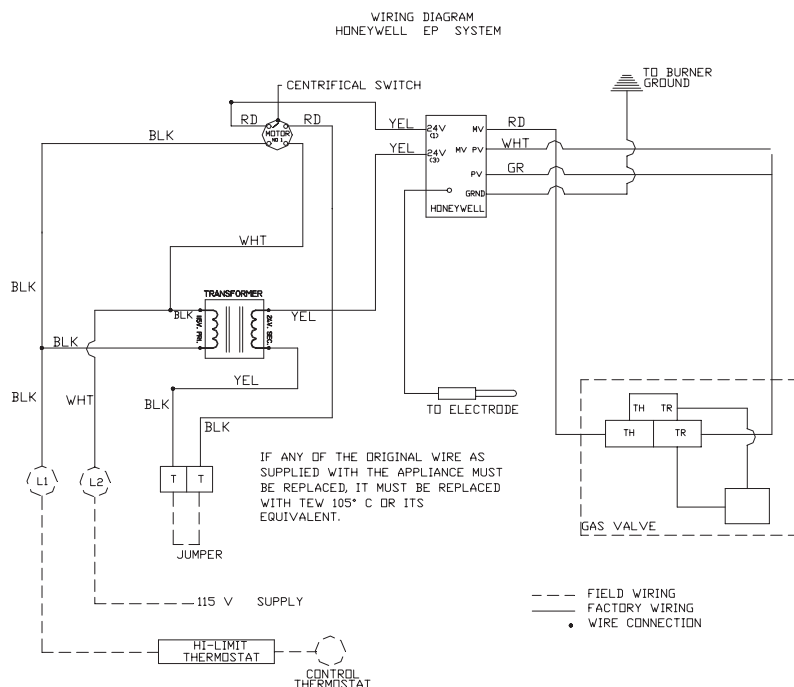

P-250EP THERMOCOUPLE PILOT LOCATION

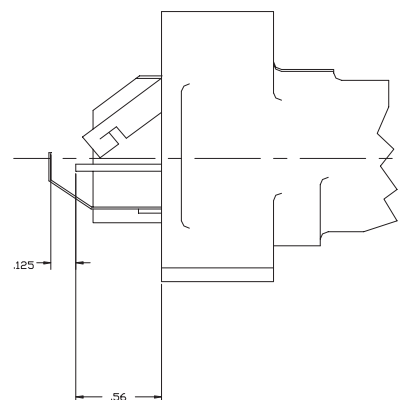

GAS PIPING INSTRUCTIONS

1. **READ ALL GAS PIPING INSTRUCTIONS CAREFULLY BEFORE MAKING GAS CONNECTIONS.**

WARNING: IMPROPER GAS HOOKUP WILL VOID WARRANTY AND COULD RESULT IN HAZARDOUS CONDITION.

2. Connect the gas line to the 1/2 inch piping that extends from the Gas Burner. A 1/2 inch N.P.T. fitting is required.

NOTE: all piping must comply with local codes and ordinances of the National Gas Code ANSI Z 223 - 1974 and NFPA #54.

3. The gas line should be a separate supply direct from the meter to the Burner. It is recommended that a new pipe be used and located so that a minimum amount of work will be required in future servicing. The piping should be so installed as to be durable, substantial, and gas tight. It should be free from cutting burrs and defects in structure and threading. Cast iron fittings or aluminum tubing should not be used for the main gas circuit. Joint compounds (pipe dope) should be used sparingly on male threads only and be approved for all gases.

NOTE: The building structure should not be weakened by installation of the gas piping. The piping should not be supported by other piping, but should be firmly supported by pipe hooks, straps, bands, or hangers. Butt or lap welded pipe pipe should not be bent.

4. The Pipe Capacity Chart must be used to determine the size pipe to use from the meter to the Burner.

PIPE SIZE	PIPE CAPACITY CHART	
	MAXIMUM LENGTH FT.	
	NAT.	L.P.
3/8	-	10
1/2	10	30
3/4	70	150
1	200	250
1 1/4	250	-

FOR GAS PRESSURE OF 0.5 PSIG OR LESS BASED ON A 0.6 AND 1.5 SPECIFIC GRAVITY GAS.

5. **TEST PIPING FOR LEAKS.** Before turning gas under pressure into piping, all openings from which gas can escape must be closed. Immediately after turning on gas, the system should be checked for leaks. This can be done by watching the 1/2 cubic foot test dial for 5 minutes to show any movement, or by soaping each pipe connection and watching for bubbles. If leak is found, make the necessary repairs and repeat the above test.

NOTE: Defective pipes or fittings should be replaced and not repaired. Never use a flame or fire of any form to locate gas leaks, use a soap solution.

6. After the piping and meter have been checked completely, **PURGE THE SYSTEM OF AIR. DO NOT** bleed the air inside the unit. Be sure to relight all the gas pilots on other appliances.

NOTE: The burner and its individual shutoff valve must be disconnected from the gas supply piping system during any pressure testing at excess of 1/2 psig.

VENTING INSTRUCTIONS

1. It is recommended that the model SPX-300 oven be vented as shown on page 23 or 24.
2. It is recommended that Local Code Officials and a Commercial Kitchen Ventilation Contractor be consulted prior to installation.
3. Provisions must be made for adequate air supply for the oven. If the oven is to be installed in a sealed room or building utilizing exhaust fans, the room must be supplied with a return air system. Return air must be equal or in excess of the exhausted air.
4. Unit must be level for proper grease drainage.
5. Minimum spacing to combustible materials: Back Side - 2" (18" recommended for service) Top - 18";
Left Side — 2" (18" recommended for service)
Note: If provision is made for service access, Left Side clearance can be reduced to 2".
Right Side — 24" (Access to load and unload firebox.);
Front — 48" (access for loading and unloading product);
Chimney Connectors-18"
Floor — May be combustible material.

NOTE: On ovens that have the reverse firebox or mirror image option, (Facing the meat loading doors the firebox door is on the right) The minimum clearance dimensions for the left side and right side will be reversed.

NOTE: For flush mount, use BBR Insulation Kit #2099.

VENTING INSTALLATIONS

INSIDE INSTALLATION

VSP HOOD SYSTEM: Purchase through Southern Pride.

MODEL VSP HOODS are U/L Listed to the applicable Southern Pride oven models and are NSF Certified.

HOOD SYSTEM TO INCLUDE;

1. Ventilation Hood.
2. Two speed fan (1320/2000).
3. Curb with vented extension and hinge kit (Specify roof pitch).
4. Grease capture trough.

SUPPLIED BY CUSTOMER:

5. Duct from hood to fan.
6. Hood Installation

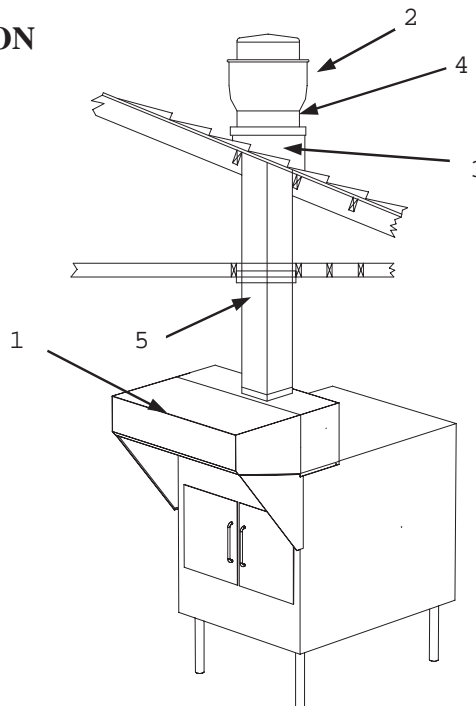

ALTERNATE INSIDE INSTALLATION

ALL OVEN MODELS MAY ALSO BE INSTALLED UNDER A CANOPY HOOD SYSTEM RATED FOR COMMERCIAL COOKING APPLIANCES.

VENTING INSTALLATIONS

THROUGH THE WALL - DIRECT VENT INSTALLATION

NOTE: When installing an Oven through a wall constructed of combustible material, use the **Southern Pride Insulation Kit** between the oven and the wall.

NOTE: The room that the face of the oven is installed into should have a balanced or positive air pressure. If the room has negative air pressure smoke could escape into the room during operation.

SUPPLIED BY SOUTHERN PRIDE: Smoke Extractor Damper with 10" chimney adapter plate.

SUPPLIED BY CUSTOMER: 6" All Fuel Chimney, 6" Rain Cap, and all accessories necessary for installation of the 6" chimney. 8" All Fuel Chimney, Exhaust Fan (NOTE: fan must be listed for use as a commercial kitchen ventilator), fan curb, and all accessories necessary for installation of the smoke extractor system.

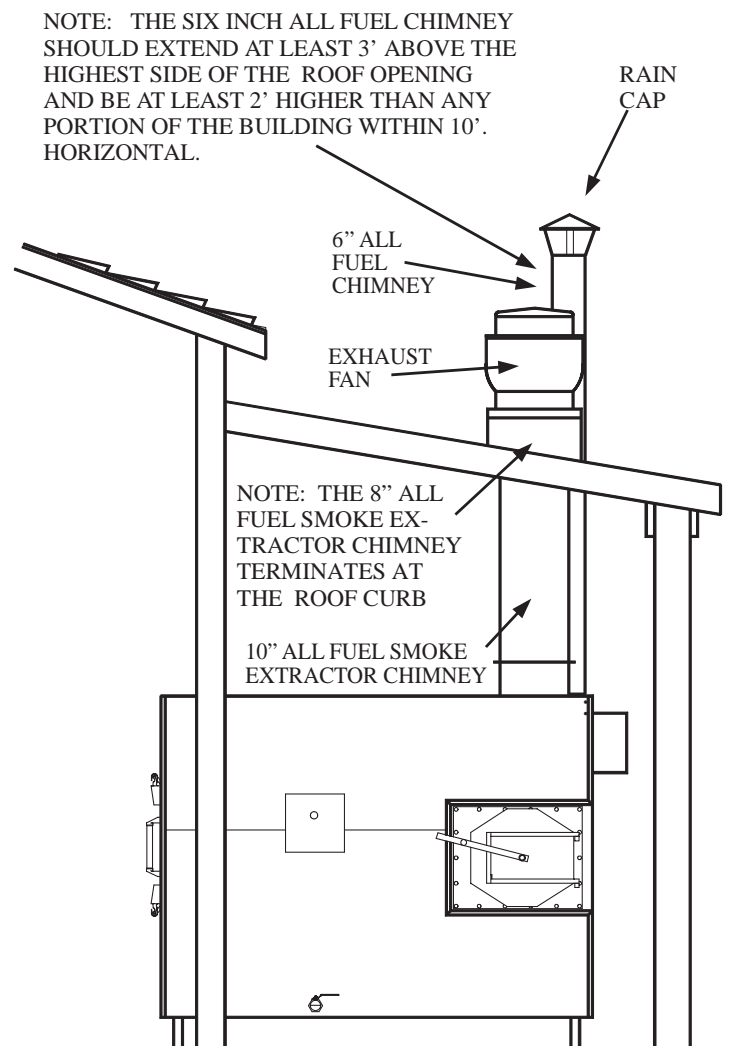

NOTE:

ANY VENTILATION SYSTEM MUST BE INSTALLED IN ACCORDANCE WITH LOCAL CODES.

CONSULT WITH LOCAL CODE OFFICIALS AND A COMMERCIAL KITCHEN VENTILATION CONTRACTOR PRIOR TO INSTALLATION.

SPX-300

REPLACEMENT PARTS LIST

PART NO.	DESCRIPTION
1002	CV Control Thermostat
1004	Bi Metal High Limit
1040	Convection Fan Motor
1041	Gas Burner
1060	Smoke Extractor Motor (SLSE option)
1062	Transformer (Gas Burner part)
1076	Blower Motor (Gas Burner part)
1080-C	Main Power Switch
1082-C	Rotisserie Advance Switch
1084	Gas Valve (Specify Natural or L.P. Gas)
1085	EP Electrode (Natural Gas)
1086	High Voltage Lead
1087	Control Module (Gas Burner part)
1088	Ignition Electrode LP
1090	Digital Control
0392	Type "K" Thermocouple
25060	Rotisserie Axle Bearing
2005	Food Rack 12" x 29" SPX-300
2029 -1	Firebox Door Gasket
2029-2	Firebox Gasket Clamp
2110	Mechanical Door Closer
2116PC	Meat Door Hinge
2426	8" Cooling Fan Blade (outside)
2428-L	10" Smoke Fan Blade (inside)
2467	2" Ball Valve (Grease Drain)
33251	SPX-300 Meat Door Gasket Set
1277	Fire Box Foam Handle Grip
35030	Gearbox SPX-300
35030-1	Start Capacitor
35010	12 Tooth Sprocket
35020	80 Tooth Sprocket
SP33660CH	SPX-300 Food Rack Hanger
SP23770CH	SPX-300 Rotisserie Wheel
25260	Shock Relay
33390	Ash Scoop
31134	Fire Box Grate
9061	(optional) Ash Scraper

**ONE YEAR LIMITED WARRANTY
(CONSULT FACTORY FOR DETAILS)
90 DAY LABOR WARRANTY (PRE AUTHORIZED)**

Southern Pride guarantees all new equipment of its manufacture to be free of defects in material and factory workmanship for a period of one year provided that the equipment is installed in the Continental United States, Alaska, or Hawaii and operated according to the Owner's Manual while located at the original address of installation, the warranty registration card has been completed and returned to the factory within fifteen (15) days after installation and a start-up has been performed by an authorized service agent.

Southern Pride's obligation under this warranty is limited to one of the following options with the option applicable to be selected by Southern Pride at the sole discretion of Southern Pride.

1. Owner to return part, freight PREPAID, Southern Pride to repair at own expense if defective, and ship part back to owner freight collect.
2. Southern Pride to furnish replacement part, freight collect, without requesting return of the defective part.
3. Southern Pride to furnish replacement part, freight collect, in exchange for return of the defective part, freight collect.

Under certain circumstances Southern Pride will reimburse owner for limited labor costs in replacing parts during a period of not more than ninety (90) days after installation, **(provided that work is prior authorized and confirmed by Southern Pride's Service Manager.)**

Because Southern Pride does not and cannot control the owner's installation, use and maintenance of equipment manufactured by Southern Pride this warranty does not cover: any equipment installed improperly; any equipment calibrated after start-up and acceptance; any component disassembled in the field; damaged due to improper cleaning, i.e. burner (hosing or "watering down" machines will cause electrical failures not covered by warranty); blown fuses, light bulbs, gaskets, electric elements and accessory components not installed or manufactured by Southern Pride. Shipping damage must be reported to the carrier and is not covered under this warranty.

Southern Pride will not be liable for damage as a result of improper installation, misuse, abuse, alteration of original design, incorrect voltage, **unauthorized service**, or breakage of fragile items, Southern Pride will not be liable for any loss or consequential damage or expense accruing directly or indirectly from the use of equipment covered by this warranty including any production or product losses or other damages which may occur as a result of equipment malfunction or failure. This warranty does not cover cooking performance, which is a function of food types, textures, temperatures and other variables chosen by the owner and over which Southern Pride has no control. The effect of corrosion, fire and normal wear on the equipment or component parts is not covered by this warranty. This warranty does not apply to damage caused by accident or to damage caused by the negligence of the owner and the employees of the owner or to damage caused by lightning generated electrical current or any other Act of God whatsoever. This warranty does not apply to any equipment bearing a serial number which has been tampered with or altered.

This warranty is exclusive and is in lieu of all other warranties, express or implied, including any implied warranty or merchantability or fitness for particular purpose, each of which is hereby expressly disclaimed, the remedies described above are exclusive and in no event shall Southern Pride be liable for special, consequential or incidental damages for the breach or delay in performance of warranty.

TERMS AND CONDITIONS

For purposes of definition and interpretation, the term "Seller" as used herein refers to Southern Pride and the term "Buyer" refers to the originator of a specific purchase order to Southern Pride.

Possession of a price list does not necessarily constitute an offer to sell by Southern Pride. Prices and specifications are subject to change without notice. All items will be invoiced at prices in effect at time of shipment. Equipment prices do not include federal, state, city or local taxes which may apply and all sales are subject thereto. No order, whether written or oral, shall result in a contract, unless it is accepted and acknowledged in writing by Seller at Seller's office in Alamo, TN.

Shipping weights are approximate and all prices are quoted F.O.B. Alamo, Tennessee. All "common carrier" shipped equipment shall be domestic crated; all others shall be uncrated and subject to delivery charge per zone chart. Any equipment held for shipment upon Buyer's request beyond the delivery date specified on original purchase order will be due and payable within terms and will result in storage charges.

Delivery estimates are figured from date written orders are received and accepted by Seller. Seller will meet Buyer's delivery request as nearly as possible but does not guarantee shipment nor delivery on any particular date. Seller reserves right to ship merchandise via any responsible carrier. Seller's responsibility ceases upon acceptance by carrier. Buyer is expected to examine contents of shipments and immediately report any damage to carrier authorities.

Payment terms shall be 30% deposit with order; balance prior to delivery unless otherwise agreed in writing by Seller. Returns of any merchandise may not be made without Seller's written approval, prior to return. Seller shall impose a 20% restocking charge for handling of any returns. All cancellations must be in writing. Cancellations are also subject to a 20% fee.