

OWNERS MANUAL



*SP-750
shown with
optional legs*

New Extended Warranty on the SP-Series oven models:

1 Year on Labor on warranty parts

1 Year on switches, relays, belts, fan blades, food racks, and wiring harness

2 Year Extended Parts Warranty on: *Rotisserie Drive Assembly (includes gear motor, chain, sprockets, bearings, rotisserie wheels, food rack hangers & rotisserie shaft) Convection Fan Assembly (includes motor, bearings, pulleys and fan blade shaft) Complete Gas Burner Assembly and Smoke Extractor Assembly (Optional feature)*

4 Year Extended Parts Warranty on:
Cabinet, Frame and Firebox Assembly

Note: The following is not covered by the above warranty: Door Gaskets, Damage or breakdowns caused by abuse, negligence due to not following recommended maintenance, cleaning, improperly loading the rotisserie or firebox, and any failures or breakdowns due to improper installation. Loss of use of an oven or loss of food product. Improper gas supply or pressure, electrical voltage loss or spikes. Unauthorized warranty work.

CONGRATULATIONS

In selecting Southern Pride, you have chosen the finest, most advanced and most fully automatic wood burning barbecue pit available. With us, “It’s Simply, a Matter of Pride”.

Please read this Instruction Manual carefully prior to installation and operation of your Southern Pride pit. Proper installation, operation, cleaning, and maintenance are essential for your satisfaction and safe operation.

KEEP THIS MANNUAL FOR REFERENCE

TABLE OF CONTENTS

Safety Information	3
Diagram of Controls & Components	4
Operating Instructions	5
Programming Instructions	7
Cold Weather Operations/Mobile oven note	8
Cleaning Instructions	9
Maintenance Schedule	10
Electrical Instructions	12
Burner Specification & Instructions	15
Gas Piping Instructions	16
Venting Instructions	17
Replacement Parts List	19
Warranty	20

SAFETY INFORMATION

FOR YOUR SAFETY

IF YOU SMELL GAS . . .

1. Open Windows.
2. Do not touch electrical switches.
3. Extinguish any open flames.
4. Immediately call your gas supplier.

DO NOT STORE OR USE GASOLINE OR OTHER FLAMMABLE VAPORS OR LIQUIDS IN THE VICINITY OF THIS OR ANY OTHER APPLIANCES.

1. The pit area **MUST** be kept clear and free of combustible materials, gasoline and other flammable vapors and liquids.
2. The flow of combustion and ventilating air **MUST NOT** be obstructed from reaching the pit.
3. The frame of the unit **MUST** be electrically grounded at all times. See “Electrical instructions”.
4. Caution should be used when opening and closing the Firebox Door. The door is **HOT** during operation.
5. **DO NOT** remove service compartment access panels when unit is in operation or leave off during operation.
6. Gas burners require the services of an experienced mechanic for proper setting and adjustment. If the burner does not appear to be operating properly, **DO NOT ATTEMPT TO ADJUST THE BURNER YOURSELF**, but call in a competent serviceman or contact Southern Pride.
7. **DO NOT** allow unqualified personnel to perform service work or adjustments on this unit. To do so, will **VOID WARRANTY** and could result in a hazardous condition.
8. Be sure any new employees, who might operate the unit, are instructed on operation and safety information prior to operating the unit.
9. Caution: Ashes removed from the Firebox should be stored in a non-combustible container with a sealed lid only. Store ashes in a well ventilated area. **FUMES COULD BE HAZARDOUS.**
10. **WARNING: IT IS EXTREMELY IMPORTANT TO FOLLOW DAILY CLEANING INSTRUCTIONS. GREASE OR SOLIDS BUILDUP INSIDE THE PIT COULD RESULT IN A FIRE HAZARD.**
11. **KEEP THIS INSTRUCTION MANUAL FOR REFERENCE.**

SP-Series CONTROLS AND COMPONENTS

1. **MEAT LOADING DOORS** - For access to Racks and Pit interior.
2. **MEAT LOADING DOOR LATCHES** - Latches apply positive pressure and seals doors.
3. **DOOR PROXIMITY SWITCH** - When doors are opened, the Rotisserie, Convection Fan and Gas Burner are automatically turned off. On ovens with an Optional Smoke Extractor the Smoke Extractor is automatically activated. On ovens with optional VSP Vent Hood Systems the exhaust fan is automatically switched to high speed.
4. **FRONT FLUE OPENING** - Allows for front venting for use under a vent hood system.
5. **DIGITAL ROAST AND HOLD CONTROL** - Provides precise control of the oven allowing the user to input Cooking temperature and Cooking time and Hold temperature. When the cooking cycle is over the Hold Cycle is started and the fan speed is switched to low speed for the hold cycle.
6. **ROTISSERIE ADVANCE FOOT SWITCH CONNECTOR** - activates the rotisserie when foot switch is depressed.
7. **FIREBOX DOOR** - Provides access for loading of wood in the Firebox Chamber.
8. **CABINET LEGS** - Provides adjustment for leveling of the unit.
9. **DRAIN VALVE** - Is opened after each cooking to drain grease.
10. **CONVECTION FAN** - Provides air flow inside the Oven for even cooking. (not shown)

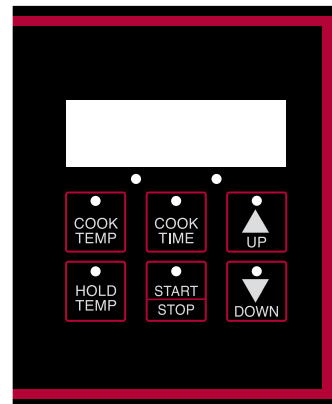
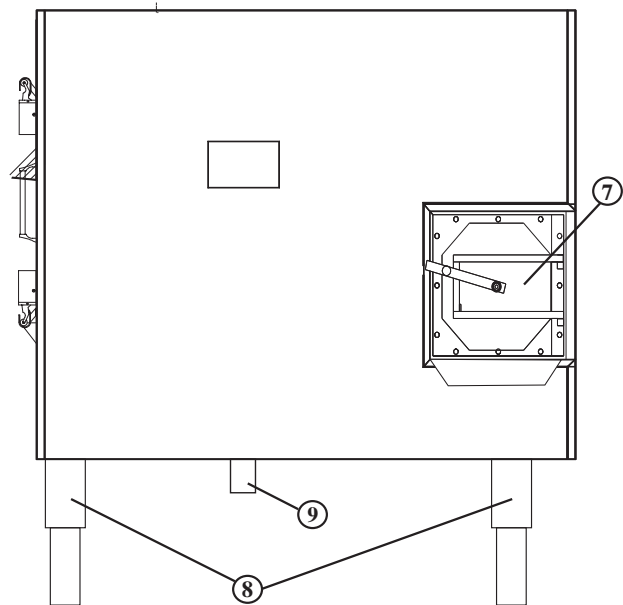
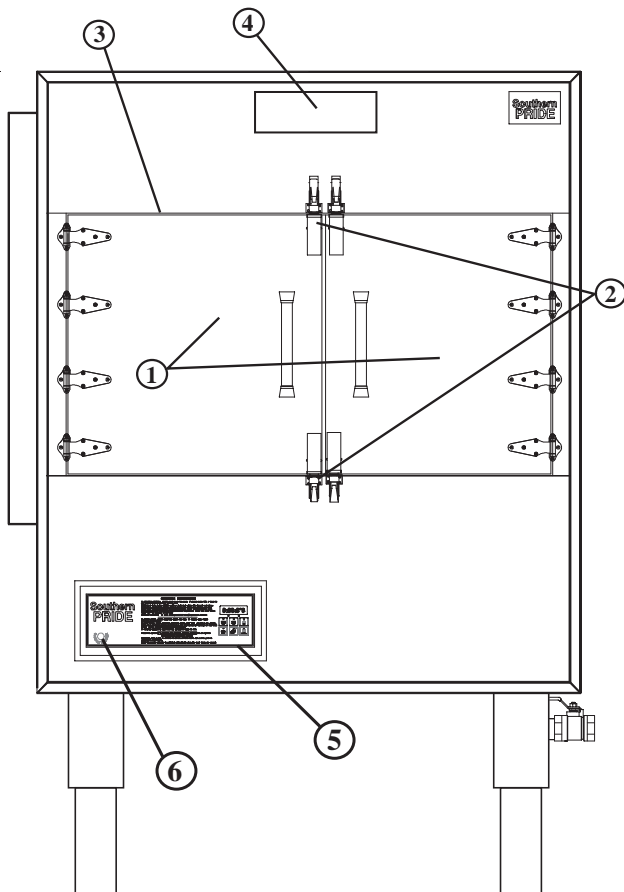

OPERATING INSTRUCTIONS

1. Load meat on the food racks. **DO NOT LET THE MEAT EXTEND BEYOND OR HANG OVER THE EDGE OF THE RACKS.**



CORRECT
Load meat on bottom rack first.



INCORRECT
May cause food to tip and meat to fall. This could cause the Rotisserie to jam.

2. To advance the racks with the Meat Doors open, press the UP arrow button or step on the rotisserie advance foot pedal until the racks advance to the next position.
3. After the meat is loaded, press the UP arrow button or step on the rotisserie advance foot pedal and allow the rotisserie to make one complete revolution. Check meat clearances to cabinet and all racks. If necessary reposition the meat on the racks for maximum clearances.
4. Open the Fire Box door and use the ash scraper to remove any ashes or log pieces that might be there from the previous cook. Dump the ashes into a metal air tight ash container.
5. Put a small amount of wood in the Firebox. Use 1-2 logs, 4-6 inches in diameter, 12-15 inches long. Use green or slightly seasoned hardwoods, fruitwoods, or charcoal. Be sure to keep the wood 6" from the burner or ashes can accumulate on the burner and cause it to not work properly. Lay the logs on top of each other at different angles to ensure good air flow around each log.



CAUTION

DO NOT USE DRY WOOD OR KINDLING.

DO NOT OVERLOAD FIREBOX. TOO MUCH WOOD CAN CAUSE OVER-HEATING OF THE PIT.

COALS AND ASHES FROM PREVIOUS COOKING MUST BE REMOVED BEFORE LOADING WOOD.

DO NOT ALLOW ASHES IN OR NEAR THE BURNER OPENING. KEEP ALL LOGS AT LEAST 6 INCHES FROM THE BURNER.

6. Be sure Firebox Door and Meat Loading Door Latches and drain valve are secured in the closed position.
7. To start the cook cycle refer to the next section “How to Program a Menu”
8. To check or unload meat, on units with optional Smoke Extractor; open the meat doors just enough to activate the Smoke Extractor, for approximately 20 seconds prior to fully opening the Meat Loading Doors, or press the Down arrow button to activate the Smoke Extractor.
9. When the meat is cooked; press and hold the start/stop button until idle appears in the LED, On models with optional Smoke Extractor press the down button to activate the smoke extractor, or open the meat doors enough to turn it on, wait for 20 seconds prior to fully opening the Meat Loading Doors. To unload racks, press the up button to advance the rotisserie or step on the pneumatic foot pedal to advance the rotisserie until the racks advance to an unloading position.
10. After each cooking, remove the remaining wood and hot coals from Firebox, then open Drain Valve and drain grease while the pit is still warm. See step 4.

CAUTION: BE SURE MEAT LOADING DOORS AND FIREBOX DOOR ARE SECURED IN THE CLOSED POSITION IMMEDIATELY FOLLOWING A COOKING AND DURING NON-USE PERIODS.

WARNING: DO NOT OPEN DRAIN VALVE WHILE PIT IS STILL IN OPERATION OR WHILE BURNING WOOD AND HOT COALS ARE STILL IN FIREBOX.

IMPORTANT

There is a small red LED light located between the Cook Temp and Cook Time button that when lit means the controller is callin for heat from the burner. The burner should be on anytime that light is lit.

Programming a Menu - (See page 4 for controller photo)

The menu consists of a cook temperature, cook time, and choice of having the control advance to a hold mode after the cook time has elapsed or end the menu when the cook time has elapsed.

- Control must be in the “IDLE” mode, if the control is “OFF” a press of any button will bring the control back to “IDLE”.
- PRESS the cook temp button, (tEnP 1 will appear in the LED display): PRESS the up/down buttons to obtain the desired cook temperature.
- PRESS the cook time button, (tinE1 will appear in the LED display): PRESS the up/down buttons to obtain the desired cook time.
- Press the hold temp. button, (HtEnp will appear in the LED display): PRESS the up/down buttons to obtain the desired hold temp., if a hold temp. is not desired: PRESS the down button until “OFF” is displayed in the LED.
- Programming the menu is complete: To start the menu, PRESS the start/stop button one time. The control will begin the menu.
- To pause the menu PRESS the start/stop button one time, to resume the menu, PRESS the start/stop button again.
- To cancel or stop the menu, PRESS and hold the start/stop button until “IDLE” is displayed in the LED.

When the cook cycle is complete there are two possible actions that can be taken. One is if a hold temperature was programmed into the menu, (if equipped) the smoke extractor will be automatically activated, for a period of five minutes, to bring the oven temperature down closer to the programmed hold temperature. Then, “HOLD” and the length of time the control has been in the hold mode will alternately flash in the LED display. The control will maintain the hold temperature until the start/stop button is depressed to “END” the menu, and bring the control to the “IDLE” mode. If the hold temperature was programmed to “OFF” then “END” will be displayed on the LED display, until the start/stop button is depressed, to “END” the menu, and bring the control to the “IDLE” mode.

- The control should be in the “IDLE” mode. (The burner, convection fan, and the rotisserie will be off)
- When the menu is in progress a PRESS of the down arrow button will activate the smoke extractor (if equipped with the optional Smoke Extractor, prior to opening the meat doors, if the doors are not opened the smoke extractor will go off after one minute and the menu will resume. If the doors are opened the menu will resume when the doors are closed. The smoke extractor will automatically activate when the doors are opened, and the menu will resume again when the doors are closed.
- When the doors are open a PRESS of the up arrow button will advance the rotisserie or a PRESS of the foot pedal will advance the rotisserie when the meat doors are open too.
- Unload the meat from the racks, using the UP arrow button to rotate the racks or depress the Rotisserie advance foot pedal.
- After each cook cycle, remove the remaining wood and coals from the firebox, then open the drain valve and drain the grease while the oven is still warm.
- After the control has been in the “IDLE” mode for five minutes it will go to “OFF”, a PRESS of any button will bring the control back to “IDLE”.

SMOKER OVEN COLD WEATHER OPERATIONS

When temperatures drop below freezing there are issues that may develop. Listed below are some of those issues and ways to correct or reduce the effects of the problem.

1. Grease in oven drain solidifies in cold weather. Listed below are things that can be done to reduce, or correct the effects of this problem.

Drain the oven after every cooking to purge the drainpipe of liquids before they solidify. In extreme cold weather conditions customers have had success wrapping the drainpipe with electric heat tape and insulating heat tape and pipe.

2. LED Displays an error 7

- a. Ovens with digital cook and hold controllers are effected by cold weather particularly when the oven is outside or when it is a through the wall installation. This error occurs when temperatures get below 32°F on the inside of the oven. The following action will generally clear the error 7 code .

- b. Moisten a cloth with warm water and wring water out, hold warm rag against top of thermocouple on the inside of oven for about 20-30 seconds. Remove rag and close door and start oven

NOTES FOR MOBILE OVENS

1. Ashes must be removed from the fire box prior to transport. Ashes can blow around inside the fire box when the oven is being towed and clog the burner causing it to not work properly.
2. Inspect the mobile rack retainer clips and pins to ensure the rack hangers are locked prior to transport.

CLEANING INSTRUCTIONS

1. Remove ashes and coals from Firebox using the ash scraper after each cook cycle.

Ash Disposal: Ashes should be placed in a non-combustible container with a tight fitting lid. The closed container of ashes should be placed on a non-combustible floor well away from all combustible material, pending final disposal.

Note: Ashes must be removed from the fire box on a mobile smoker prior to transport.



CAUTION: Fumes could be hazardous.

2. Be sure hot coals and wood are removed from the Firebox before opening drain valve.
3. Open Drain Valve and drain Grease.
4. Remove food racks and clean thoroughly. (Racks simply lift out of the brackets on the hangers.) To remove food rack hangers, lift hanger and pull straight back over Rotisserie Wheel Stubs.
5. Thoroughly clean complete interior of pit. Use food service degreaser. Spray degreaser on the interior of the pit and allow to set for 5-10 minutes. Rinse thoroughly with water hose or pressure washer. Drain through Drain Valve. Follow the Degreaser Manufacturer instructions and wear protective gear as needed.

WARNING

IT IS EXTREMELY IMPORTANT TO FOLLOW THE ABOVE **DAILY** CLEANING PROCEDURES. GREASE OR SOLIDS BUILDUP INSIDE THE PIT COULD RESULT IN A **FIRE HAZARD**.

MAINTENANCE SCHEDULE

AFTER EACH USE: Drain Grease and empty ashes from the firebox.

DAILY: Remove and clean all of the food racks. Thoroughly clean the complete interior of the oven, using a food service degreaser (follow instructions on degreaser) and rinse with a water hose or pressure washer. Drain through the drain valve.

WEEKLY:

1. Inspect Burner Head for accumulation of ashes and creosote. Clean as needed.
2. Inspect Convection Fan Blade for buildup of solids, or out of balance condition. Clean or replace as needed. Clean light bulbs as needed. Use side access door for fan cleaning or replacement.
3. Inspect meat Loading and Firebox Door Gaskets. Replace if damaged or leaking.
4. Inspect Smoke Extractor Louver to be sure it closes completely. Clean or repair as needed. (If equipped with the optional Smoke Extractor)

BI-MONTHLY INTERVAL

1. For Direct Vented ovens with a Smoke Extractor, the Smoke Extractor Damper and chimney should be inspected at least twice monthly for creosote buildup.
2. The Flue Pipe should be carefully inspected. Remove any solids buildup that has accumulated.

Creosote - Formation and need for removal:

When wood is burned slowly, it produces tar and other organic vapors, which combine with expelled moisture to form creosote. The creosote vapors condense in the relatively cool chimney flue of a slow burning fire. As a result, creosote residue accumulates on the flue lining. When ignited, this creosote makes an extremely hot fire.

IF CREOSOTE HAS ACCUMULATED IT SHOULD BE REMOVED TO REDUCE THE RISK OF A CHIMNEY FIRE.

ANNUALLY

Drive Chain lubrication instructions

1. To lubricate the Drive Chain, disconnect the power supply to the oven and remove the Drive Cover.
2. Use only quality SAE 20 oil for lubricating the Drive Chain.
3. The drive chain for the SP-Series Oven should be lubricated once each year.
4. Use a clean brush to apply oil to the slack side of the Drive Chain.



Meat Door Latch Removal Instructions

The meat door latches are removable for cleaning.

To Remove:

1. Make sure your BBQ oven is off and has had time to cool down then open meat doors.
2. CAUTION: The latch rollers are spring-loaded and will spring open quickly with a lot of force, don't pinch a finger or hand. Un-cock or Release the latch roller by pushing up on the roller. See Photo 1.
3. Next use a screwdriver to pop the meat door latch loose from the oven, see photo 2.
4. Once the latch is off, clean it, inside and out as well as the meat door front, using conventional cleaners.
5. To Re-install the latch: Position it over the latch backing plate as per the photo 3 and slide top of latch assembly over the backing plate tabs.
6. Next using the palm of your hand or a rubber mallet tap the bottom of the latch, until it locks back onto the retaining tabs as per the photo 4.
7. CAUTION: The latch rollers are spring-loaded and will spring open quickly with a lot of force, don't pinch a finger or hand. You are now ready to cock the latch roller. Cock the latch roller by pushing down on it until it is set in the fully open position. Make sure latch roller is fully cocked before you release it. Photo 5.



photo 1



photo 2



photo 3



photo 4

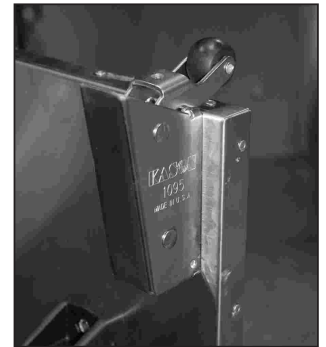

photo 5

ELECTRICAL INSTRUCTIONS

ELECTRICAL REQUIREMENTS:

120 Volts A.C. with ground, 60 hz.,
2 wire, single phase,
20 amp wiring required.

WARNING:

**CHASSIS MUST BE GROUNDED TO
PREVENT POSSIBLE SHOCK HAZARD.
DO NOT ASSUME A PLUMBING LINE
WILL PROVIDE SUCH A GROUND.**

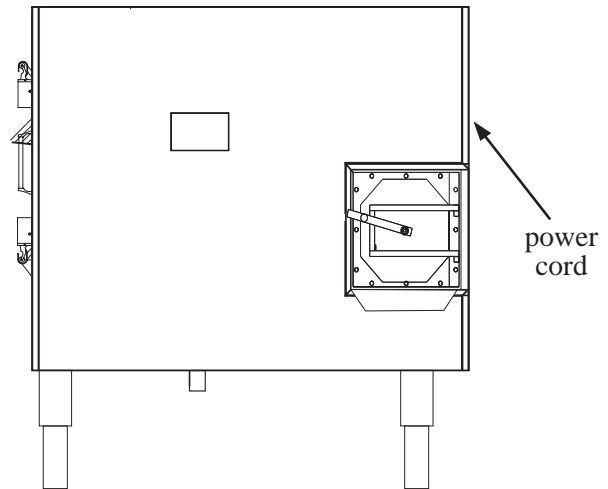

WARRANTY IS VOID IF UNIT IS CONNECTED TO ANY VOLTAGE OTHER THAN SPECIFIED ABOVE AND ON NAMEPLATE.

1. Electrician must provide the conduit and wire for hookup.
2. Power is to be left **OFF** throughout installation.
3. Electrical Service is connected via the factory supplied power cord located on the back left corner of the oven.
4. On models with optional Smoke Extractor, electrician must provide conduit and wire for hookup from Junction Box above the Smoke Extractor Motor on the top of the pit to the Exhaust fan. Make electrical connections inside the Junction box.

NOTE: THIS IS NOT A POWER SUPPLY CONNECTION. IT IS FOR A FAN CONNECTION ONLY.

NOTE: 125 V.A.C., 1/4 hp maximum connected load, 1100 cfm fan rating recommended.

5. If venting or gas connections are to be done later, be sure that power is **OFF**.

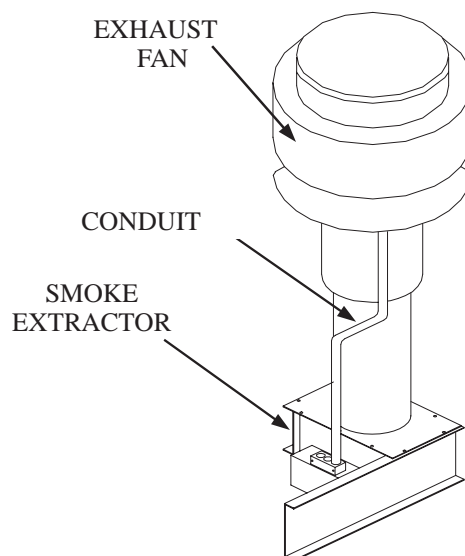

SP-SERIES GAS OVEN WIRING DIAGRAM WITH
 DIGITAL ROAST & HOLD CONTROL SMOKE EXTRACTOR &
 HOOD READY

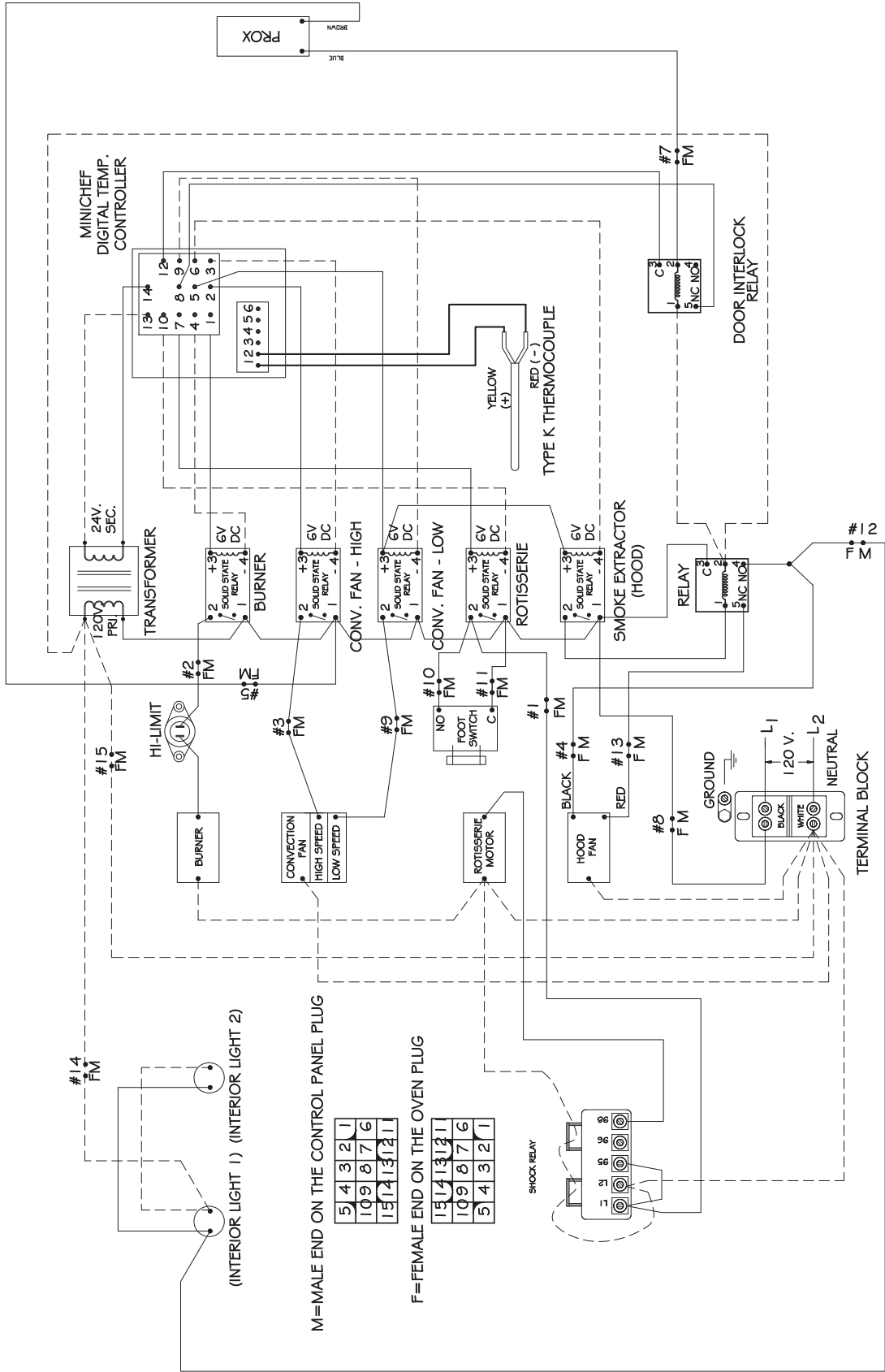

NOTE: IF USING THE OPTIONAL VSP HOOD TO VENT THE OVEN, THEN THE OVEN SHOULD BE PLUGGED INTO A SWITCHED RECEPTACLE TO BE ABLE TO SHUT OFF THE HOOD.

ITEMS TO CHECK BEFORE FIRING BURNER

IMPORTANT

**WARNING: IMPROPER GAS HOOKUP WILL VOID WARRANTY
AND COULD RESULT IN A HAZARDOUS CONDITION.**

1. Gas line **MUST** be installed by a competent technician and in accordance with this Manual.
2. Gas line **MUST** include an easily accessible manual shutoff valve, drip leg, and pressure gauge port.
3. Gas pipe size **MUST** be in accordance with the Pipe Capacity Chart in this Manual.
4. Gas line **MUST** be tested for leaks under pressure.
5. Gas Line **MUST** be purged to remove any air in the system.
6. Gas line pressure **MUST** be checked and **MUST NOT** exceed the maximum pressure specified in the Burner Specifications in this Manual.
7. Burner Orifice **MUST** correlate with the type of gas being supplied, as specified in the Burner Specifications in this Manual.

GAS PIPING INSTRUCTIONS

1. **READ ALL GAS PIPING INSTRUCTIONS CAREFULLY BEFORE MAKING GAS CONNECTIONS.**

WARNING: IMPROPER GAS HOOKUP WILL VOID WARRANTY AND COULD RESULT IN HAZARDOUS CONDITION.

2. Connect the gas line to the 1/2 inch piping that extends from the Gas Burner. A 1/2 inch N.P.T. fitting is required.

NOTE: all piping must comply with local codes and ordinances of the National Gas Code ANSI Z 223.1 - 2006 and NFPA #54.

3. The gas line should be a separate supply direct from the meter to the Burner. It is recommended that a new pipe be used and located so that a minimum amount of work will be required in future servicing. The piping should be so installed as to be durable, substantial, and gas tight. It should be free from cutting burrs and defects in structure and threading. Cast iron fittings or aluminum tubing should not be used for the main gas circuit. Joint compounds (pipe dope) should be used sparingly on male threads only and be approved for all gases.

NOTE: The building structure should not be weakened by installation of the gas piping. The piping should not be supported by other piping, but should be firmly supported by pipe hooks, straps, bands, or hangers. Butt or lap welded pipe pipe should not be bent.

4. The Pipe Capacity Chart must be used to determine the size pipe to use from the meter to the Burner.

PIPE SIZE	PIPE CAPACITY CHART	
	MAXIMUM LENGTH FT.	
	NAT.	L.P.
3/8	-	10
1/2	10	30
3/4	70	150
1	200	250
1 1/4	250	-

FOR GAS PRESSURE OF 0.5 PSIG OR LESS BASED ON A 0.6 AND 1.5 SPECIFIC GRAVITY GAS.

5. **TEST PIPING FOR LEAKS.** Before turning gas under pressure into piping, all openings from which gas can escape must be closed. Immediately after turning on gas, the system should be checked for leaks. This can be done by watching the 1/2 cubic foot test dial for 5 minutes to show any movement, or by soaping each pipe connection and watching for bubbles. If leak is found, make the necessary repairs and repeat the above test.

NOTE: Defective pipes or fittings should be replaced and not repaired. Never use a flame or fire of any form to locate gas leaks, use a soap solution.

6. After the piping and meter have been checked completely, **PURGE THE SYSTEM OF AIR. DO NOT** bleed the air inside the unit. Be sure to relight all the gas pilots on other appliances.

NOTE: The burner and its individual shutoff valve must be disconnected from the gas supply piping system during any pressure testing at excess of 1/2 psig.

VENTING INSTRUCTIONS

1. It is recommended that the model SP-Series oven be vented as shown.
2. It is recommended that Local Code Officials and a Commercial Kitchen Ventilation Contractor be consulted prior to installation.
3. Provisions must be made for adequate air supply for the oven. If the oven is to be installed in a sealed room or building utilizing exhaust fans, the room must be supplied with a return air system. Return air must be equal or in excess of the exhausted air.
4. Unit must be level for proper grease drainage.
5. Minimum spacing to combustible materials: Back Side - 2" (18" recommended for service)
Top - 18"
Left Side — 2" (18" recommended for service)
Right Side — 24" (Access to load and unload firebox.);
Front — 48" (access for loading and unloading product);
Chimney Connectors-18"
Floor — May be combustible material.

NOTE: For flush mount, use BBR Insulation Kit #2099.

VENTING INSTALLATIONS

INSIDE INSTALLATION

VSP HOOD SYSTEM: Purchase through Southern Pride.

MODEL VSP HOODS are U/L Listed to the applicable Southern Pride oven models and are NSF Certified.

HOOD SYSTEM TO INCLUDE;

1. Ventilation Hood.
2. Two speed fan (1320/2000).
3. Curb with vented extension and hinge kit (Specify roof pitch).
4. Grease capture trough.

SUPPLIED BY CUSTOMER:

5. Duct from hood to fan.
6. Hood Installation

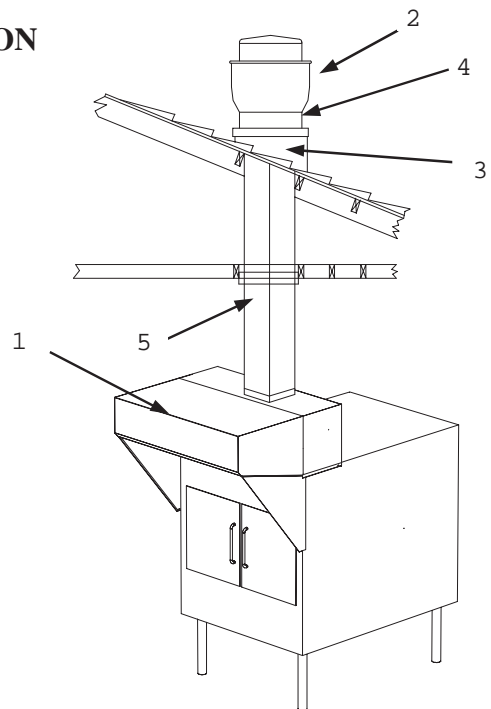

ALTERNATE INSIDE INSTALLATION

ALL OVEN MODELS MAY ALSO BE INSTALLED UNDER A CANOPY HOOD SYSTEM RATED FOR COMMERCIAL COOKING APPLIANCES.

VENTING INSTALLATIONS

THROUGH THE WALL - DIRECT VENT INSTALLATION

NOTE: When installing an Oven through a wall constructed of combustible material, use the **Southern Pride Insulation Kit** between the oven and the wall.

NOTE: The room that the face of the oven is installed into should have a balanced or positive air pressure. If the room has negative air pressure smoke could escape into the room during operation.

SUPPLIED BY SOUTHERN PRIDE: Smoke Extractor Damper with 10" chimney adapter plate.

SUPPLIED BY CUSTOMER: 6" All Fuel Chimney, 6" Rain Cap, and all accessories necessary for installation of the 6" chimney. 8" All Fuel Chimney, Exhaust Fan (NOTE: fan must be listed for use as a commercial kitchen ventilator), fan curb, and all accessories necessary for installation of the smoke extractor system.

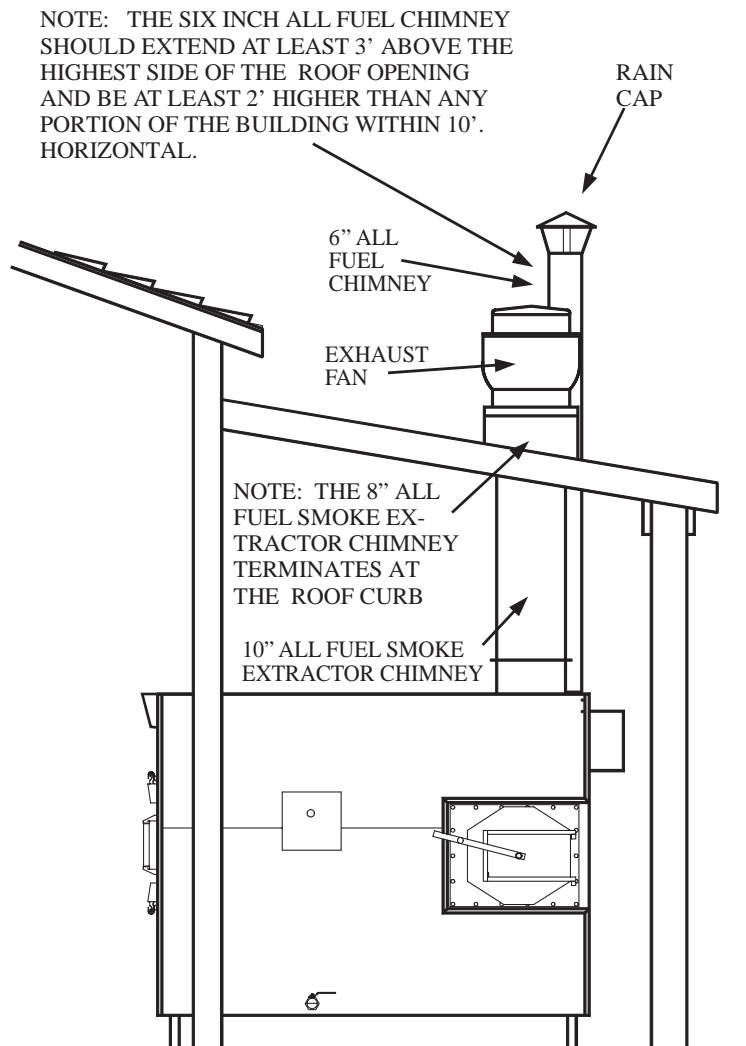

NOTE:

ANY VENTILATION SYSTEM MUST BE INSTALLED IN ACCORDANCE WITH LOCAL CODES.

CONSULT WITH LOCAL CODE OFFICIALS AND A COMMERCIAL KITCHEN VENTILATION CONTRACTOR PRIOR TO INSTALLATION.

SP-Series Ovens Replacement Parts List

PART NO.	DESCRIPTION
1268	Rotisserie Bearing 1-1/2" Bore
1270	Convection Fan Pillow Block
1271	Convection Fan Drive Belt
1040-5	Convection Fan Motor
55026	Drive Chain Tensioner
1039-2	Proximity Switch - High Temp
7184	High Limit Gasket
394	High Limit 450°
25040	Burner
2428L	10" Fan Blade
2426	8" Fan Blade
25260	Shock Relay
55030	Gearmotor
55020	Large Sprocket
55010	Small Sprocket
1220	Digital Control
2116	Meat Door Hinge
2112	Meat Door Closer
4103A	Meat Door Handle
101929	Meat Door Gasket
25250	100w Shatter Resistant Bulb
392	1" Thermocouple
1057	Foot Switch
1056	Foot Pedal
1164	Control Panel Mylar
9296	Food Rack Retainer Pin
653660	SP-750 Hanger Rack
103660	SP-1000 Hanger Rack
2180	SP-750 Flat Rack (12"x42")
2188A	SP-1000 Flat Rack (18"x42")
2180R	SP-750 Rib Rack (12"x42")
2188R	SP-1000 Rib Rack (18"x42")
1092	10 amp Solid State Relay
1059	24V CONTROL Transformer
103200	Rotisserie Wheel
103785	Relay Board
103781	Smoke Extractor
101812	S/E Blank off Plate
1063	S/E Actuator
0304	High Temp. Food Grease
103852	Ash Scraper
2029	Firebox Door Gasket
2467-1	2" Ball Valve
1045-2	Contactator
1068	Circuit Breaker (4amp)
1085	EP Electrode Natural Gas
1088	EP Electrode LP
1086	High Voltage Lead
1084	Gas Valve

**ONE YEAR LIMITED WARRANTY PLUS NEW EXTENDED WARRANTY (SEE FRONT COVER)
(CONSULT FACTORY FOR DETAILS) 1 YEAR LABOR WARRANTY (PRE AUTHORIZED)**

Southern Pride guarantees all new equipment of its manufacture to be free of defects in material and factory workmanship for a period of one year provided that the equipment is installed in the Continental United States, Alaska, or Hawaii and operated according to the Owner's Manual while located at the original address of installation, the warranty registration card has been completed and returned to the factory within fifteen (15) days after installation and a start-up has been performed by an authorized service agent.

Southern Pride's obligation under this warranty is limited to one of the following options with the option applicable to be selected by Southern Pride at the sole discretion of Southern Pride.

1. Owner to return part, freight PREPAID, Southern Pride to repair at own expense if defective, and ship part back to owner freight collect.
2. Southern Pride to furnish replacement part, freight collect, without requesting return of the defective part.
3. Southern Pride to furnish replacement part, freight collect, in exchange for return of the defective part, freight collect.

Under certain circumstances Southern Pride will reimburse owner for limited labor costs in replacing parts during a period of not more than one year after installation, **(provided that work is prior authorized and confirmed by Southern Pride's Service Manager.)**

Because Southern Pride does not and cannot control the owner's installation, use and maintenance of equipment manufactured by Southern Pride this warranty does not cover: any equipment installed improperly; any equipment calibrated after start-up and acceptance; any component disassembled in the field; damaged due to improper cleaning, i.e. burner (hosing or "watering down" machines will cause electrical failures not covered by warranty); blown fuses, light bulbs, gaskets, electric elements and accessory components not installed or manufactured by Southern Pride. Shipping damage must be reported to the carrier and is not covered under this warranty.

Southern Pride will not be liable for damage as a result of improper installation, misuse, abuse, alteration of original design, incorrect voltage, **unauthorized service**, or breakage of fragile items, Southern Pride will not be liable for any loss or consequential damage or expense accruing directly or indirectly from the use of equipment covered by this warranty including any production or product losses or other damages which may occur as a result of equipment malfunction or failure. This warranty does not cover cooking performance, which is a function of food types, textures, temperatures and other variables chosen by the owner and over which Southern Pride has no control. The effect of corrosion, fire and normal wear on the equipment or component parts is not covered by this warranty. This warranty does not apply to damage caused by accident or to damage caused by the negligence of the owner and the employees of the owner or to damage caused by lightning generated electrical current or any other Act of God whatsoever. This warranty does not apply to any equipment bearing a serial number which has been tampered with or altered.

This warranty is exclusive and is in lieu of all other warranties, express or implied, including any implied warranty or merchantability or fitness for particular purpose, each of which is hereby expressly disclaimed, the remedies described above are exclusive and in no event shall Southern Pride be liable for special, consequential or incidental damages for the breach or delay in performance of warranty.

TERMS AND CONDITIONS

For purposes of definition and interpretation, the term "Seller" as used herein refers to Southern Pride and the term "Buyer" refers to the originator of a specific purchase order to Southern Pride.

Possession of a price list does not necessarily constitute an offer to sell by Southern Pride. Prices and specifications are subject to change without notice. All items will be invoiced at prices in effect at time of shipment. Equipment prices do not include federal, state, city or local taxes which may apply and all sales are subject thereto. No order, whether written or oral, shall result in a contract, unless it is accepted and acknowledged in writing by Seller at Seller's office in Alamo, TN.

Shipping weights are approximate and all prices are quoted F.O.B. Alamo, Tennessee. All "common carrier" shipped equipment shall be domestic crated; all others shall be uncrated and subject to delivery charge per zone chart. Any equipment held for shipment upon Buyer's request beyond the delivery date specified on original purchase order will be due and payable within terms and will result in storage charges.

Delivery estimates are figured from date written orders are received and accepted by Seller. Seller will meet Buyer's delivery request as nearly as possible but does not guarantee shipment nor delivery on any particular date. Seller reserves right to ship merchandise via any responsible carrier. Seller's responsibility ceases upon acceptance by carrier. Buyer is expected to examine contents of shipments and immediately report any damage to carrier authorities.

Payment terms shall be 30% deposit with order; balance prior to delivery unless otherwise agreed in writing by Seller. Returns of any merchandise may not be made without Seller's written approval, prior to return. Seller shall impose a 20% restocking charge for handling of any returns. All cancellations must be in writing. Cancellations are also subject to a 20% fee.