

Southern PRIDE

WOOD BURNING BBQ PITS & SMOKERS

MODEL SC-600-SM

OWNERS / OPERATIONS MANUAL

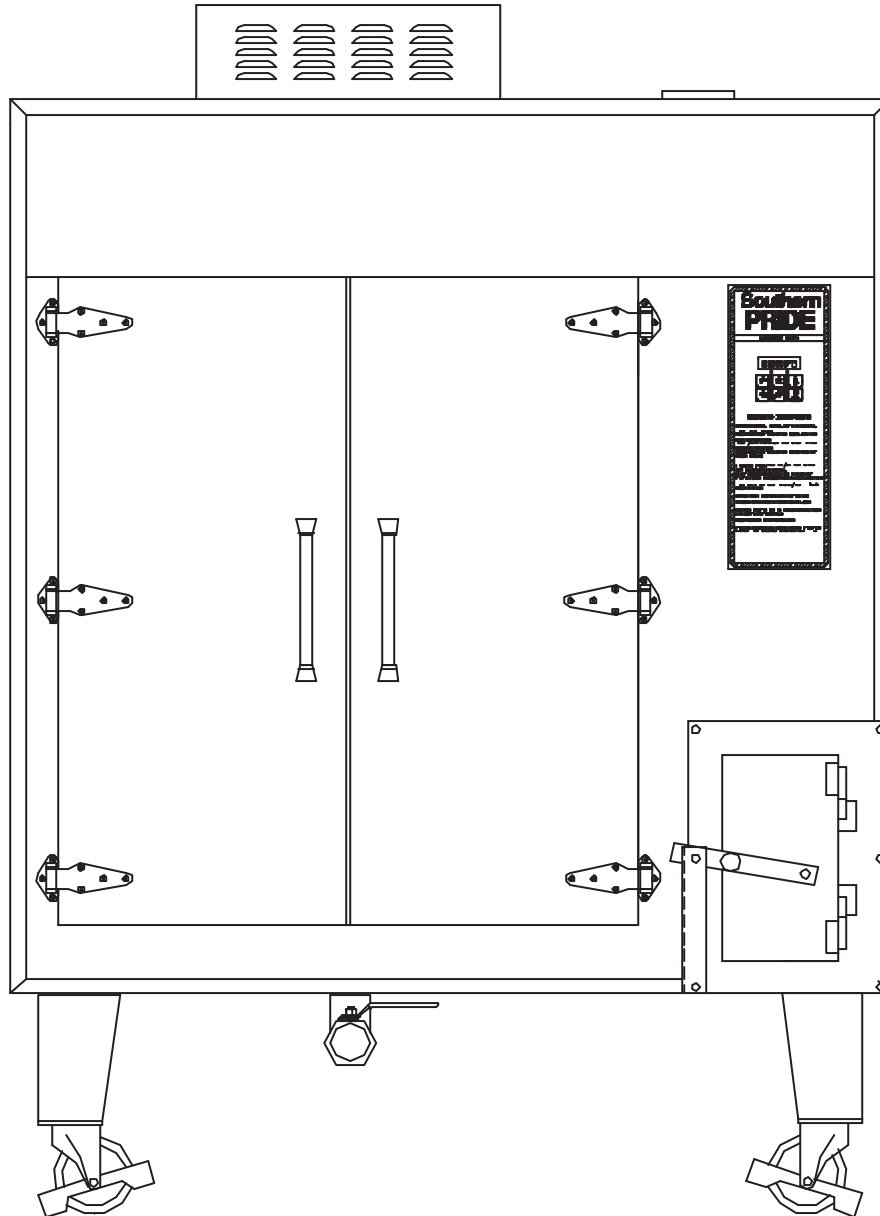

Southern PRIDE

WOOD BURNING BBQ PITS & SMOKERS

472 South Mill Street, Alamo TN 38001

SALES: 800-851-8180

FAX: 618-993-5960

www.southern-pride.com

sales@sopride.com

service@sopride.com

SERVICE: 800-437-2679

SERVICE FAX: 618-993-0378

parts@sopride.com

***** CONGRATULATIONS *****

In selecting **SOUTHERN PRIDE**, you have chosen the finest, most advanced, and fully automatic smoker / oven available. With us, *"It's A Matter Of Pride"*.

Please read this INSTRUCTION MANUAL carefully prior to installation and operation. Proper installation, operation, and cleaning are essential for your satisfaction and safe operation.

KEEP THIS MANUAL FOR REFERENCE

TABLE OF CONTENTS

	Page
Safety Information	1
Oven Controls & Features.....	2&3
Operating Instructions.....	4-6
Cleaning Instructions.....	7
Electrical Instructions	8
Installation Instructions.....	9
Wiring Diagram.....	10
Warranty.....	11

SAFETY INFORMATION

1. Be sure all untrained employees, who may operate this oven, are instructed on the proper operation and safety information prior to working with this oven.
2. Oven surfaces are HOT when oven is in operation. Proper utensils and protective gear should be used with this appliance.
3. Oven cleaners can be HAZARDOUS. read and follow all labeled instructions.
4. The frame of the oven MUST be electrically grounded at all times. See “Electrical instructions” in this manual. FAILURE TO GROUND THIS UNIT MAY RESULT IN AN ELECTRICAL SHOCK.
5. Do not remove the service compartment access panel unless power to the oven is OFF.
6. Do not allow unqualified personnel to perform service work. To do so will VOID WARRANTY and could be hazardous.
7. CAUTION: Ashes removed from ovens equipped with smoker should be extinguished immediately with water.
8. Daily cleaning is extremely important to insure FIRE SAFETY and FOOD SAFETY.

OVEN CONTROLS & FEATURES

1. **CONVECTION FAN COVER**- Removable cover for service on the convection fan.
2. **AUTOMATIC DOOR CLOSERS**- Automatically holds tension on the door when in the closed position.
3. **ELECTRONIC CONTROL**- Adjustable time and temperature setting (150-325 degrees F) with cook and hold. Maintains the desired oven temperature by controlling the main heat element..
4. **Fan Shroud** - Main element and blower wheel cover, can be removed for cleaning.
5. **Food Racks** - 8- 33 1/2" x 31" nickel chrome plated wire food racks, slide out for easy loading and unloading of product.
6. **Casters** - For ease of moving the oven, the front casters are locking.
7. **DRAIN**- 2" ball valve drain for easy removal of grease after each cooking.
8. **Side Channels** - Acts as an air channel to direct air flow in the oven, and hold the slides for the food racks. Both are easily removable for cleaning.
9. **ASH PAN** - The ash pan catches the ashes from the burnt wood .
10. **BURNER ELEMENT** - This element is activated when wood smoke is desired. The wood is placed directly on this element. (Sawdust or charcoal or wood chips can also be used with the optional chip pan.
11. **SERVICE DOOR** - The service door is located on the right side of the oven and is removable by removing the four screws , one on each corner of the door.

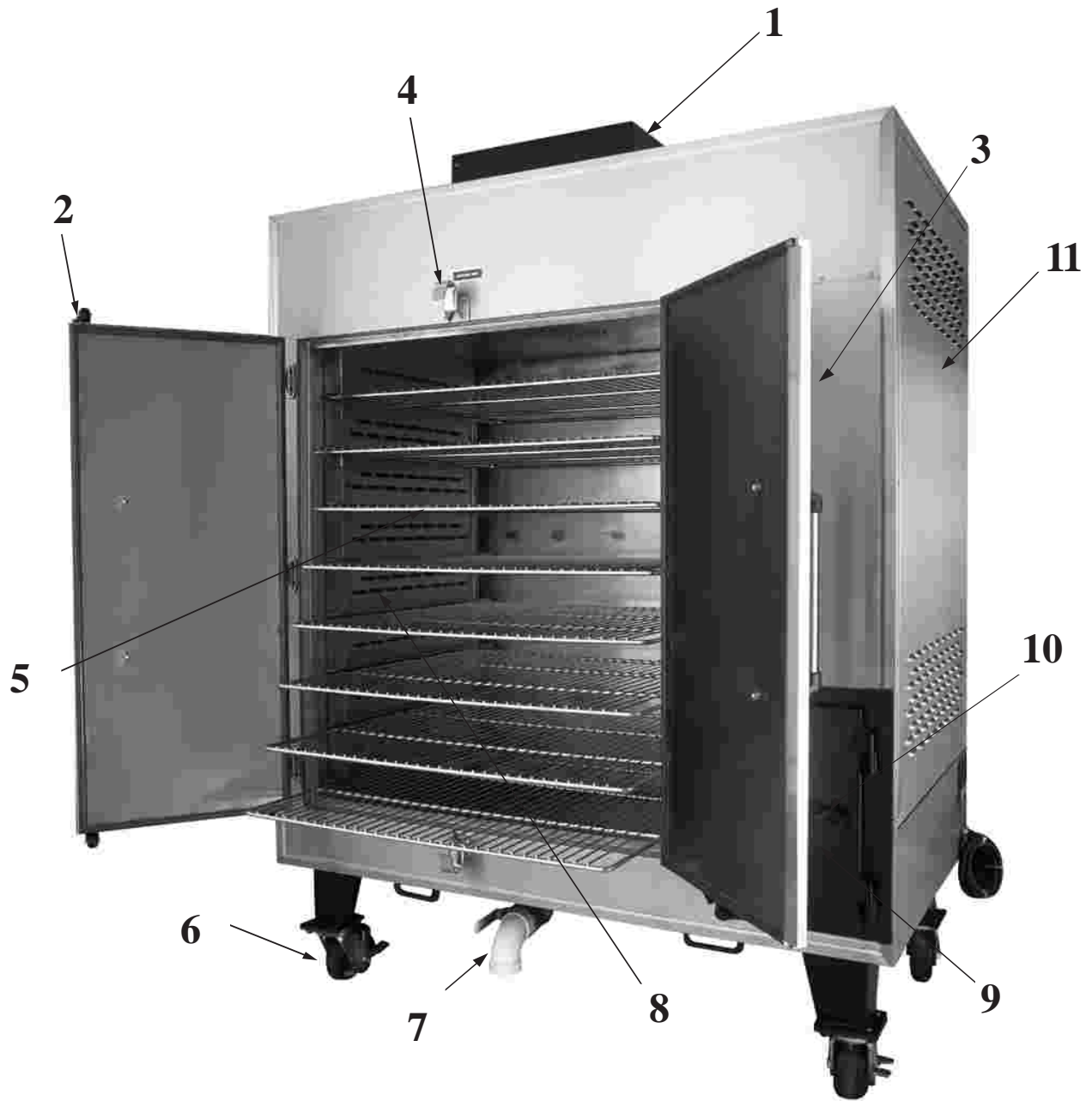

OPERATING INSTRUCTIONS

WARNING- The element cover and both side channels must be in place before loading or operating the oven!

Loading the product:

1. The SC-600-SM convection oven is equipped with “Eight ”- 33 1/2” x 31” food racks for the loading of food products. The racks slide in and out for easy loading and unloading. Sheet pans may be used instead of the food racks. Lay the product directly on the food racks. Flat items such as ribs, pork chops, half chickens, etc. can be loaded on each shelf. Larger items, depending on size, may require the removal of every other food rack.
2. The grease drain is located under the doors of the oven. The grease should be drained after each cook cycle. The drain must be closed during cooking cycle.

If the product is to be smoked:

3. Place a hardwood log, hardwood chunks, wood chips, charcoal or sawdust into the chip pan and slide the chip pan over the smoker element.

To Program a menu:

The menu consists of a cook temperature, cook time, hold temperature, and CHIPS which turns the smoker on or off for the menu.

4. Control must be in the “**IDLE**” mode, if the control is “**OFF**” a press of any button will bring the control back to “**IDLE**”

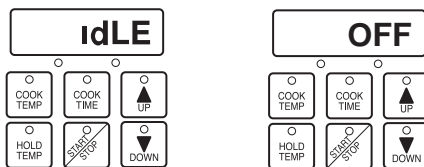

5. **PRESS** the *cook temp* button, (tEnP 1 will appear in the LED display): **PRESS** the *up/down* buttons to obtain the desired cook temperature.

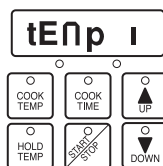

6. **PRESS** the *cook time* button, (**tiNE 1** will appear in the display): **PRESS** the *up/down* buttons to obtain the desired cook time.

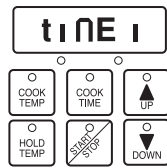

7. **PRESS** the *hold temp* button, (**HtEnP** will appear in the **LED** display): **PRESS** the *up/down* buttons to obtain the desired hold temp, If a hold temp is not desired: **PRESS** the *down* button until “**OFF**” is displayed in the **LED**.



Programming The menu is complete:

8. To start the menu, **PRESS** the *start/stop* button one time. “**CHIPS**” will appear in the **LED** display. Two actions are possible, a touch to the *up* button will start the menu with the wood chip smoker “**ON**” or a touch to the *down* button will start the menu with the wood chip smoker “**OFF**”. The control will begin the menu.

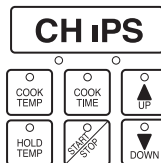

9. One press of the *start/stop* button will pause the menu, to resume the menu, press the *start/stop* button again.

10. To cancel or stop the menu, press and hold the *start/stop* button until “**IDLE**” is displayed in the **LED**.

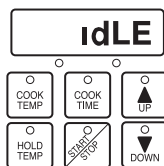

When cook cycle is complete:

11. Two actions are possible after the cook time expires.

If a hold temperature was programmed into the menu, then the control will sound an audible alarm, momentarily, and “**Hold**” will appear in the **LED** display. The length of time the control has been in the hold mode, and the word “**Hold**” will be displayed alternately in the **LED** display. The control will maintain the hold temperature until the *start/stop* button is depressed to “**END**” the menu, and bring the control to the “**IDLE**” mode.

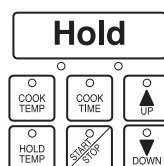

If the hold temperature was programmed to “OFF” then “END” will be displayed on the LED, and an audible alarm will sound continuously until the *start/stop* button is depressed, to end the menu, and bring the control to the “IDLE” mode.

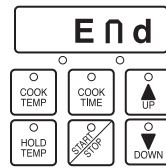

12. The control should be in the “IDLE” mode, (the main heater element, convection fan motor, and the smoker will be off).
13. If the smoke was used for the menu, remove any unburned wood. Dispose of the wood and ashes in a fireproof container. **CAUTION!** The firebox will be **HOT** use protective gear.
14. Unload the food product and drain the grease from the bottom of the oven.
15. When the control has been in the “IDLE” mode for five minutes, without a touch to any button, it will go to “OFF” , a press of any button will bring the control back to “IDLE”.

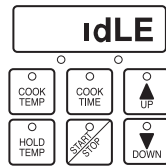

CLEANING INSTRUCTIONS

Oven should be cleaned daily to remove any grease or carbon deposits. Poor cleaning habits can be both a food and fire hazard.

Mild dish detergents will remove most of the grease on all the surfaces of the oven. For areas with build up that cannot be removed with soapy water, use conventional oven cleaners.

CAUTION: Always wear protective clothing and eyewear when using oven cleaners. Read labeled directions and warnings.

NOTE: The area above heating element cover on top of the inside can be cleaned by removing the front element cover. Loosen the back two 1/4-20 bolts on the back side of the element cover and then remove the front two bolts slide the element cover to the front and then pull straight out to remove. After cleaning,
COVER MUST BE INSTALLED BEFORE OPERATING OVEN.

Clean the outside of the oven with commercial stainless steel cleaners and polishes. **NEVER** use any abrasive scrub pads on the outside of the oven.

ELECTRICAL

120/208 Volts AC or
120/240 Volts AC
60 Hz
Single Phase
45 AMP wiring required

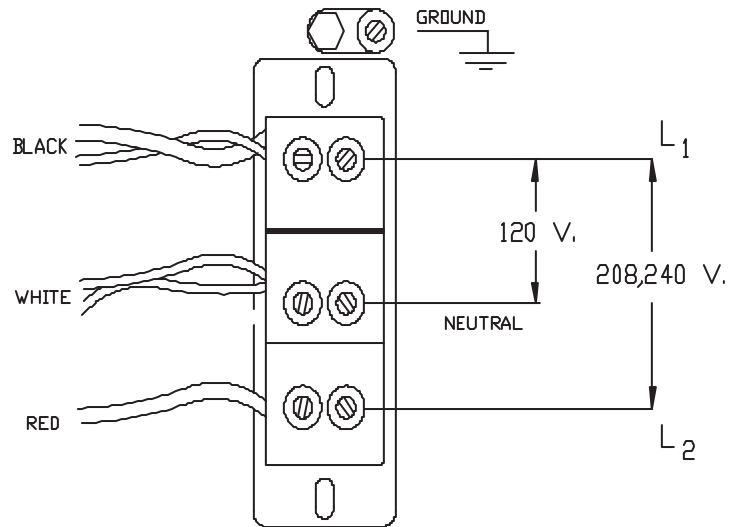

NOTE: MAKE SURE THE SUPPLY
POWER CORRESPONDS WITH
VOLTAGE SPECIFIED ON THE
NAMEPLATE.

WARNING:

CHASSIS MUST BE GROUNDED TO PREVENT POSSIBLE SHOCK
HAZARD.

WARRANTY IS VOID IF THE OVEN IS CONNECTED TO ANY VOLTAGE
OTHER THAN SPECIFIED ABOVE.

ELECTRICAL INSTRUCTIONS

1. Electrician must provide 8 AWG stranded four wire cable and plug for hookup.
2. Power must be OFF during installation.
3. Electrical service is provided at the terminal block, located behind the service compartment door which is located on the right side of the oven.
4. After connecting the proper electrical service, test the voltage at the terminal block with a voltmeter.
5. If power is correct replace the access panel and power up the oven.

INSTALLATION INSTRUCTIONS

1. Read and follow the electrical requirements on the previous page to insure proper connection of the oven.
2. While this oven is in operation it will emit smoke from the vent stack or from the meat door opening if it is opened. Adequate space should be allowed for this oven under a hood to insure that the hood will capture the smoke.
3. Venting for the SC-600-SM must be with an exhaust ventilation system in accordance with the National Fire Protection Association Standard for Ventilation Control and Fire Protection of Commercial Cooking Operations, NFPA 96. Local codes may supercede this recommendation. Check local building codes prior to installation.

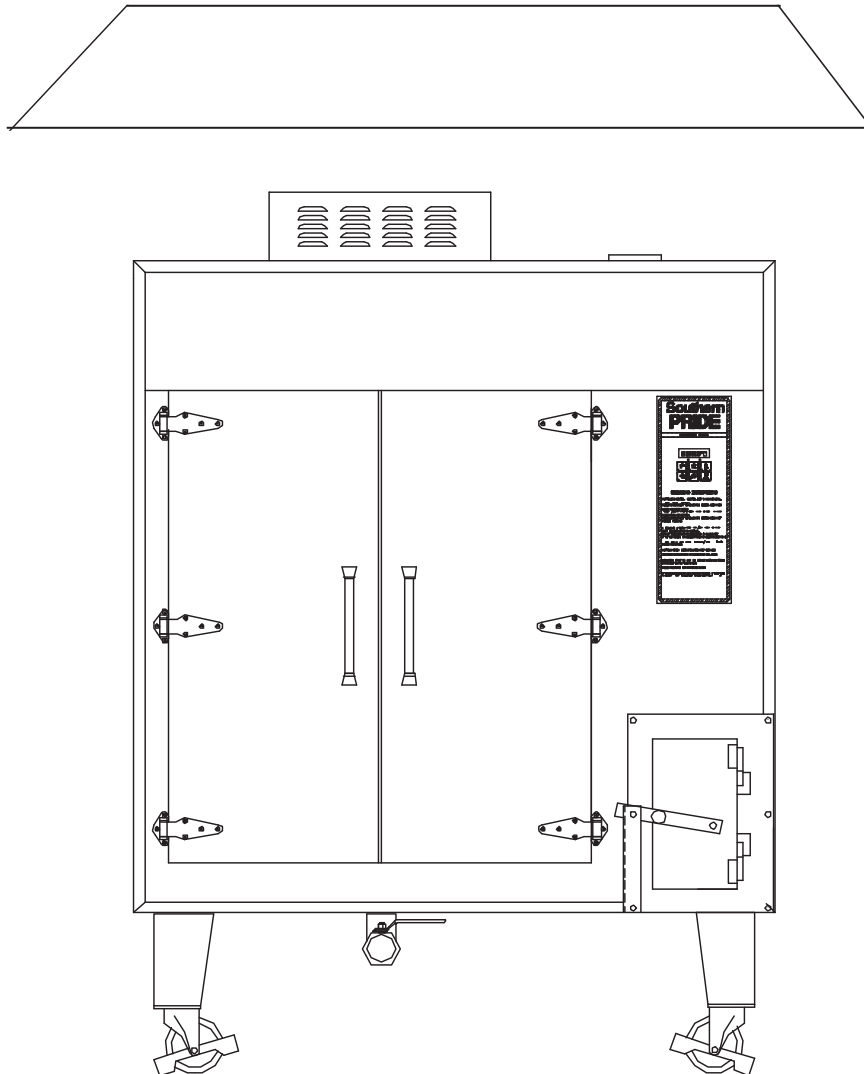

**1 Year LIMITED WARRANTY
(CONSULT FACTORY FOR DETAILS)
90 DAY LABOR WARRANTY (PRE AUTHORIZED)**

Southern Pride guarantees all new equipment of its manufacture to be free of defects in material and factory workmanship for a period of one year provided that the equipment is installed in the Continental United States, Alaska, or Hawaii and operated according to the Owner's Manual while located at the original address of installation, the warranty registration card has been completed and returned to the factory within fifteen (15) days after installation and a start-up has been preformed by an authorized service agent.

Southern Pride's obligation under this warranty is limited to one of the following options with the option applicable to be selected by Southern Pride at the sole discretion of Southern Pride.

1. Owner to return part, freight PREPAID, Southern Pride to repair at own expense if defective, and ship part back to owner freight collect.
2. Southern Pride to furnish replacement part, freight collect, without requesting return of the defective part.
3. Southern Pride to furnish replacement part, freight collect, in exchange for return of the defective part, freight collect.

Under certain circumstances Southern Pride will reimburse owner for limited labor costs in replacing parts during a period of not more than ninety (90) days after installation, **(provided that work is prior authorized and confirmed by Southern Pride's Service Manager.)**

Because Southern Pride does not and cannot control the owner's installation, use and maintenance of equipment manufactured by Southern Pride this warranty does not cover: any equipment installed improperly; any equipment calibrated after start-up and acceptance; any component disassembled in the field; damaged due to improper cleaning, i.e. burner (hosing or "watering down" machines will cause electrical failures not covered by warranty); blown fuses, light bulbs, gaskets, electric elements and accessory components not installed or manufactured by Southern Pride. Shipping damage must be reported to the carrier and is not covered under this warranty.

Southern Pride will not be liable for damage as a result of improper installation, misuse, abuse, alteration of original design, incorrect voltage, **unauthorized service**, or breakage of fragile items, Southern Pride will not be liable for any loss or consequential damage or expense accruing directly or indirectly from the use of equipment covered by this warranty including any production or product losses or other damages which may occur as a result of equipment malfunction or failure. This warranty does not cover cooking performance, which is a function of food types, textures, temperatures and other variables chosen by the owner and over which Southern Pride has no control. The effect of corrosion, fire and normal wear on the equipment or component parts is not covered by this warranty. This warranty does not apply to damage caused by accident or to damage caused by the negligence of the owner and the employees of the owner or to damage caused by lightning generated electrical current or any other Act of God whatsoever. This warranty does not apply to any equipment bearing a serial number which has been tampered with or altered.

This warranty is exclusive and is in lieu of all other warranties, express or implied, including any implied warranty or merchantability or fitness for particular purpose, each of which is hereby expressly disclaimed, the remedies described above are exclusive and in no event shall Southern Pride be liable for special, consequential or incidental damages for the breach or delay in performance of warranty.

TERMS AND CONDITIONS

For purposes of definition and interpretation, the term "Seller" as used herein refers to Southern Pride and the term "Buyer" refers to the originator of a specific purchase order to Southern Pride.

Possession of a price list does not necessarily constitute an offer to sell by Southern Pride. Prices and specifications are subject to change without notice. All items will be invoiced at prices in effect at time of shipment. Equipment prices do not include federal, state, city or local taxes which may apply and all sales are subject thereto. No order, whether written or oral, shall result in a contract, unless it is accepted and acknowledged in writing by Seller at Seller's office in Marion, Illinois.

Shipping weights are approximate and all prices are quoted F.O.B. Marion, Illinois. All "common carrier" shipped equipment shall be domestic crated; all others shall be uncrated and subject to delivery charge per zone chart. Any equipment held for shipment upon Buyer's request beyond the delivery date specified on original purchase order will be due and payable within terms and will result in storage charges.

Delivery estimates are figured from date written orders are received and accepted by Seller. Seller will meet Buyer's delivery request as nearly as possible but does not guarantee shipment nor delivery on any particular date. Seller reserves right to ship merchandise via any responsible carrier. Seller's responsibility ceases upon acceptance by carrier. Buyer is expected to examine contents of shipments and immediately report any damage to carrier authorities.

Payment terms shall be 30% deposit with order; balance prior to delivery unless otherwise agreed in writing by Seller. Returns of any merchandise may not be made without Seller's written approval, prior to return. Seller shall impose a 20% restocking charge for handling of any returns. All cancellations must be in writing. Cancellations are also subject to a 20% fee.