

**Southern  
PRIDE**

**MODEL XLR-350-SLSE**  
(Reference XLR-350)

---

# INSTRUCTION MANUAL

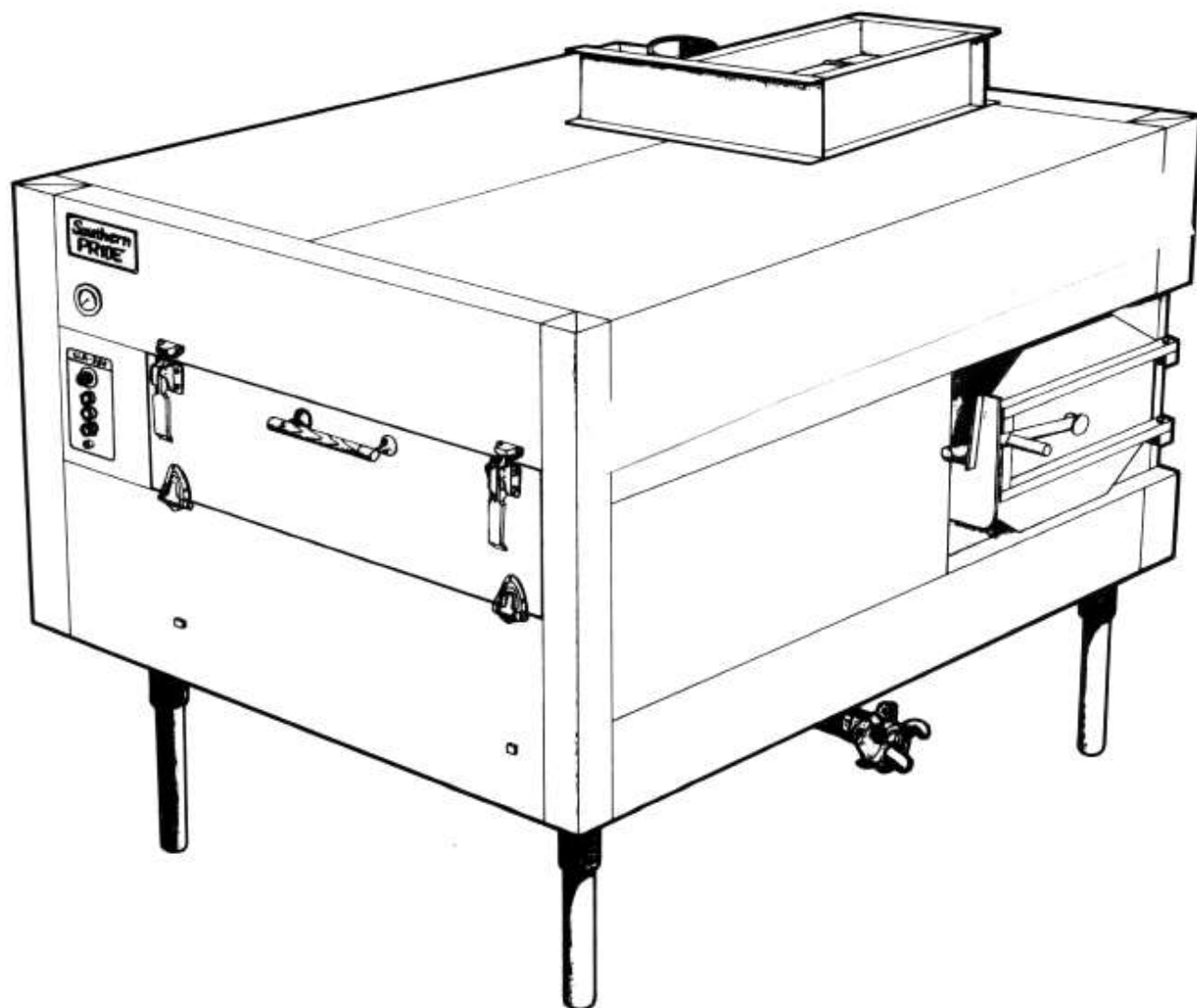

# ★ ★ ★ CONGRATULATIONS ★ ★ ★

In selecting **SOUTHERN PRIDE**, you have chosen the finest, most advanced, and fully automatic wood burning barbecue pit available. With us, "It's A Matter Of Pride".

Please read this **INSTRUCTION MANUAL** carefully prior to installation and operation. Proper installation, operation, cleaning, and maintenance are essential for your satisfaction and safe operation.

## KEEP THIS MANUAL FOR REFERENCE

### TABLE OF CONTENTS

	Page
Safety Information .....	1-2
Diagram of Controls & Components .....	3- 4
Operating Instructions .....	5-6-7
Cleaning Instructions .....	8-9
Maintenance Schedule .....	10-11
Installation Instructions	
Electrical .....	12
Burner Specifications .....	13
Items to Check Before Firing Burner .....	14
Gas Piping .....	15-16
Venting .....	17
Venting Diagram .....	18
Wiring Schematic .....	19
Wiring Diagram .....	19
Limited Warranty .....	20
Replacement Parts List .....	21

# SAFETY INFORMATION

## FOR YOUR SAFETY

### IF YOU SMELL GAS . . .

1. Open Windows.
2. Do not touch electrical switches.
3. Extinguish any open flames.
4. Immediately call your gas supplier.

**DO NOT STORE OR USE GASOLINE OR OTHER FLAMMABLE VAPORS OR LIQUIDS IN THE VICINITY OF THIS OR ANY OTHER APPLIANCES.**

1. The oven area **MUST** be kept clear and free of combustible materials, gasoline and other flammable vapors and liquids.
2. The flow of combustion and ventilating air **MUST NOT** be obstructed from reaching the oven.
3. The frame of the oven **MUST** be electrically grounded at all times. See "Electrical Instructions" in this manual.

### **FAILURE TO GROUND THIS UNIT MAY RESULT IN AN ELECTRICAL SHOCK.**

4. Caution should be used when opening and closing the Firebox Door located inside the oven. The door is **HOT** during operation.
5. **DO NOT** remove service compartment access panels when unit is in operation or leave off during operation.
6. Gas burners require the services of an experienced technician for proper setting and adjustment. If the burner does not appear to be operating properly, **DO NOT ATTEMPT TO ADJUST THE BURNER YOURSELF**, but call in a competent serviceman or contact Southern Pride.
7. **DO NOT** allow unqualified personnel to perform service work or adjustments on this unit. To do so, will **VOID WARRANTY** and could result in a hazardous condition.
8. Be sure any new employees, who might operate the unit, are instructed on operation and safety information prior to operating the oven.
9. Caution: Ashes removed from the Firebox should be stored in a non-combustible container with a sealed lid only. Store ashes in a well ventilated area. **FUMES COULD BE HAZARDOUS.**
10. **WARNING: IT IS EXTREMELY IMPORTANT TO FOLLOW DAILY CLEANING INSTRUCTIONS. EXCESS GREASE OR SOLIDS BUILDUP INSIDE THE OVEN COULD RESULT IN A FIRE HAZARD.**
11. **KEEP THIS INSTRUCTION MANUAL FOR REFERENCE.**

## **CAUTION**

This pit is designed to operate on a controlled air intake system in order to control the combustion of the wood in the firebox.

### **DO NOT OPERATE PIT UNDER ANY OF THE FOLLOWING CONDITIONS:**

1. **DO NOT** operate pit unless the Firebox Door and Meat Loading Door Latches are secured in the closed position.
2. **DO NOT** leave Firebox Door or Meat Loading Door open while pit is unattended.
3. **DO NOT** use aluminum foil or any other protective material on inner liner surfaces or food racks of pit.
4. **DO NOT** open Drain Valve while pit is in operation or while burning wood and hot coals are still in firebox.
5. **DO NOT** operate pit if Firebox Door or Meat Loading Door Gaskets are damaged or missing.
6. **DO NOT** operate pit unless daily cleaning procedures have been performed to remove solids buildup inside the pit.
7. **DO NOT** operate pit unless operator has been thoroughly trained on operation, safety and cleaning procedures.

## **WARNING**

**FAILURE TO OBSERVE THESE WARNINGS COULD RESULT IN A  
FIRE HAZARD**

# SOUTHERN PRIDE'S XLR-350-SLSE

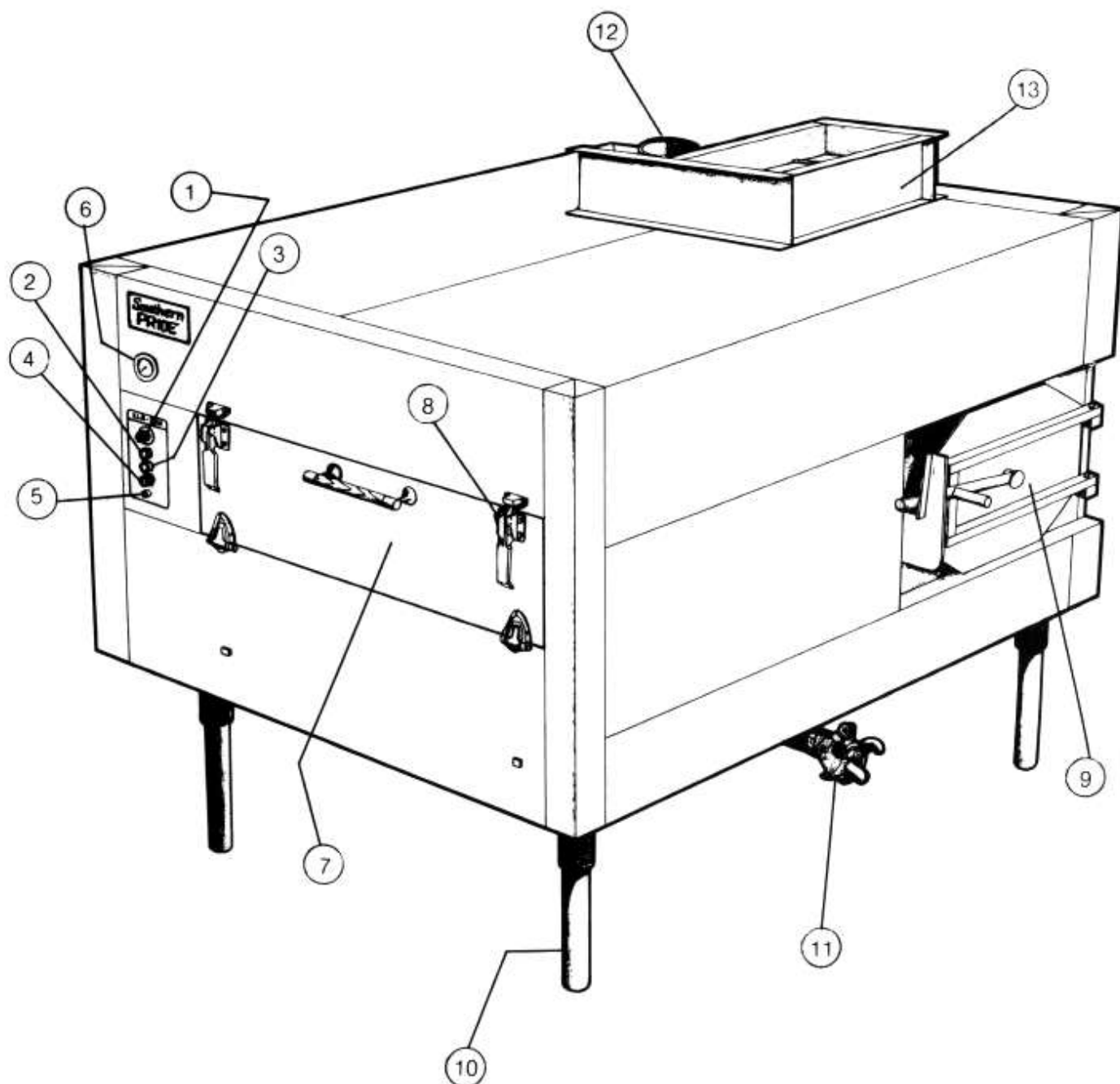

# **XLR-350-SLSE CONTROLS AND COMPONENTS**

1. **CONTROL THERMOSTAT** – Adjustable temperature setting (100-325°F) with OFF position. Maintains desired Pit temperature by controlling the Gas Burner.
2. **MAIN POWER SWITCH** – Activates the Rotisserie, Convection Fan, Burner, and Red Indicator Lamp. (The Red Indicator Lamp on the Main Power Switch indicates when the switch is ON.)
3. **ROTISSERIE ADVANCE SWITCH** – Momentarily activates Rotisserie to advance the food racks for loading and unloading when Meat Door is open or Main Power Switch is OFF.
4. **SMOKE EXTRACTOR SWITCH** – Activates Smoke Extractor Damper, Exhaust Fan, and Blue Indicator Lamp. (The Blue Indicator Lamp on the Smoke Extractor Switch indicates when the switch is ON.) At the same time it de-activates Burner and Red Indicator Lamp.
5. **CIRCUIT BREAKER** – Provides protection for the Rotisserie Drive Motor.
6. **DIAL THERMOMETER** – Shows at a glance the interior temperature of the pit.
7. **MEAT LOADING DOOR** – For access to Racks and Pit interior.
8. **MEAT LOADING DOOR LATCHES** – Latches apply positive pressure and seals doors.
9. **FIREBOX DOOR** – Provides access for loading of wood in the Firebox Chamber.
10. **CABINET LEGS** – Provides adjustment for leveling of the unit.
11. **DRAIN VALVE** – Is opened after each cooking to drain grease.
12. **FLUE COLLAR** – For connection of 6" Flue.
13. **SMOKE EXTRACTOR DAMPER** – Closes to hold smoke inside pit while cooking and opens for Exhaust Fan to remove smoke when Smoke Extractor Switch is ON or when Meat Loading Door is open.

## OPERATING INSTRUCTIONS

1. Load meat on the food racks. Always load bottom rack first and distribute the weight evenly on all five sets of food racks. **DO NOT LET THE MEAT EXTEND BEYOND OR HANG OVER THE EDGE OF THE RACKS.**

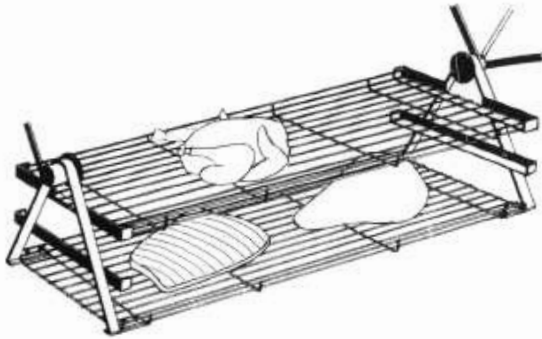

### CORRECT

Load meat on bottom rack first.

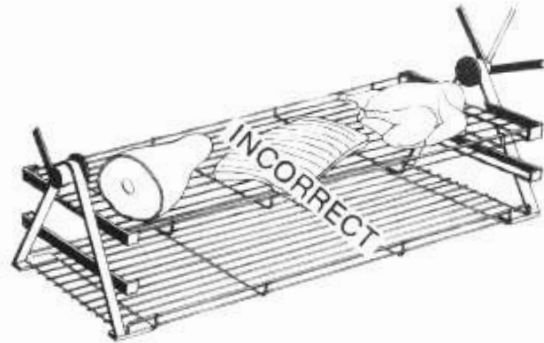

### WRONG

May cause food racks to tip and meat to fall. This could cause the Rotisserie to jam.

2. To advance the racks with the Meat Door open, depress the Rotisserie Advance Switch until the racks advance to the next position.
3. After the meat is loaded, depress Rotisserie Advance Switch and allow Rotisserie to make one complete revolution. Check meat clearances to cabinet and all racks. Reposition meat on racks for maximum clearances.
4. Put a small amount of wood in Firebox. **Use 2-3 logs, 4-6 inches in diameter, 12-15 inches long.** Use green or slightly seasoned hardwoods only.

**CAUTION: DO NOT USE DRY WOOD OR KINDLING.**

DO NOT OVERLOAD FIREBOX. TOO MUCH WOOD CAN CAUSE OVERHEATING OF THE PIT.

COALS AND ASHES FROM PREVIOUS COOKING MUST BE REMOVED BEFORE LOADING WOOD.

DO NOT ALLOW ASHES IN OR NEAR THE BURNER OPENING. KEEP ALL LOGS AT LEAST 6 INCHES FROM THE BURNER.

Correct way to load wood. Use 2-3 hardwood logs, 4-6 inches in diameter, 12-15 inches long.

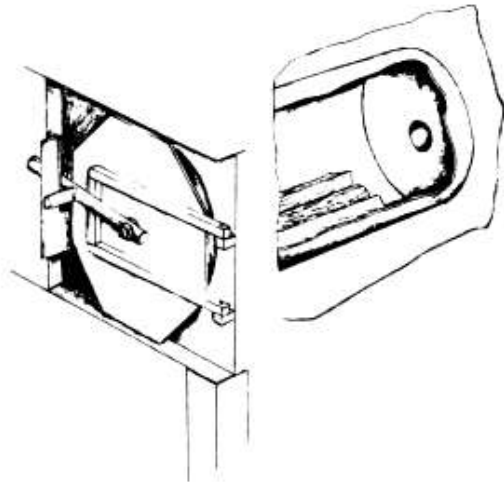

Use Ash Scraper to aid in the removal of ashes and coals from the Firebox.

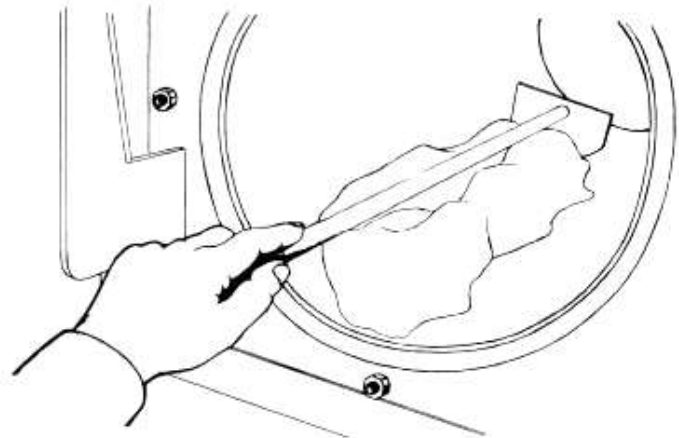

5. Be sure Firebox Door and Meat Loading Door Latches are secured in the closed position.
6. Set the Thermostat to the desired temperature setting.
7. Depress the Main Power Switch to the **ON** position. The wood will be ignited and cooking temperature will be maintained automatically. (The red lamp on the Main Power Switch indicates when the switch is **ON**.)

8. To check or unload meat, depress the Smoke Extractor Switch to the **ON** position and wait 20 seconds prior to opening the Meat Loading Door. (The blue lamp on the Smoke Extractor Switch indicates when the switch is **ON**.)

**NOTE:** Smoke Extractor will come **ON** automatically when the Meat Loading Door is opened. However, we recommend that the above procedure be followed to eliminate smoke from exiting the door when it is first opened.

**CAUTION: DO NOT LEAVE SMOKE EXTRACTOR SWITCH ON DURING THE COOKING PROCESS.**

9. When the meat is cooked, depress the Main Power Switch to the **OFF** position. Before opening Meat Door, depress the Smoke Extractor Switch to the **ON** position and wait 20 seconds. To unload racks, depress the Rotisserie Advance Switch until the racks advance to an unloading position.
10. After each cooking, remove the remaining wood and hot coals from Firebox, then open Drain Valve and drain grease from the Grease Pan while the pit is still warm.

**CAUTION: BE SURE MEAT LOADING DOOR AND FIREBOX DOOR ARE SECURED IN THE CLOSED POSITION IMMEDIATELY FOLLOWING A COOKING AND DURING NON-USE PERIODS.**

**WARNING: DO NOT OPEN DRAIN VALVE WHILE PIT IS IN OPERATION OR WHILE BURNING WOOD AND HOT COALS ARE STILL IN FIREBOX.**

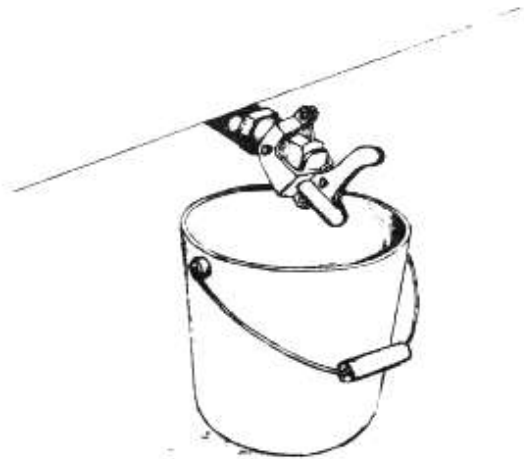

### **IMPORTANT**

The Gas Burner is equipped with an automatic ignition system. To ignite, depress the Main Power Switch to the **ON** position and set Thermostat to desired temperature. To shut Burner **OFF**, depress the Main Power Switch to the **OFF** position.

# CLEANING INSTRUCTIONS

1. Remove ashes and coals from Firebox after each cooking.

**Ash Disposal:** Ashes should be placed in a non-combustible container with a tight fitting lid. The closed container of ashes should be placed on a non-combustible floor well away from all combustible material, pending final disposal.

Use Ash Scraper to aid in the removal of ashes and coals from the Firebox.

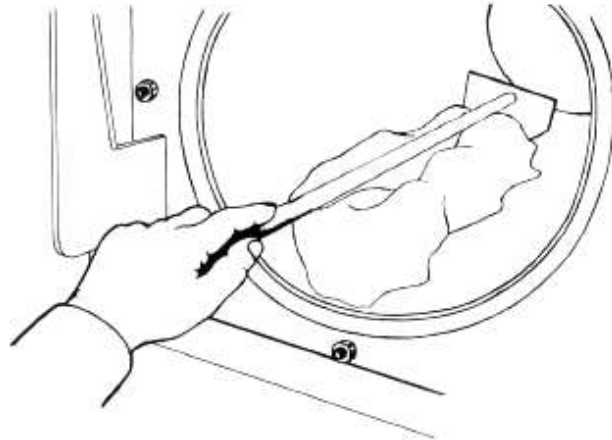

Place ashes and coals in a non-combustible container with a tight fitting lid.

**CAUTION:** Fumes could be hazardous.

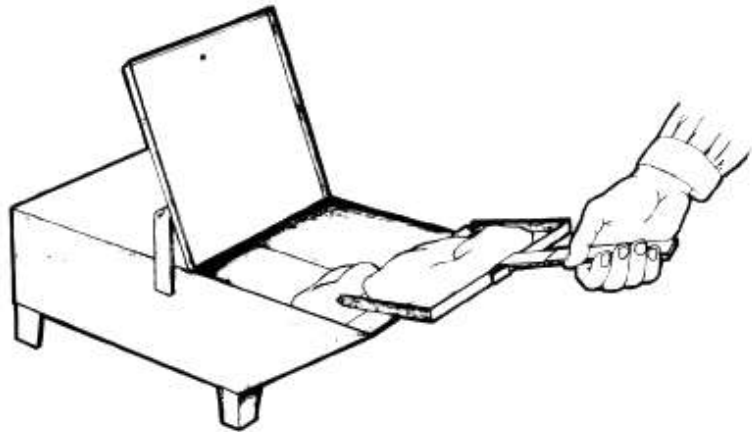

2. Drain grease. (Be sure hot coals and wood are removed from the Firebox before opening Drain Valve.)

Open Drain Valve and drain Grease Pan.

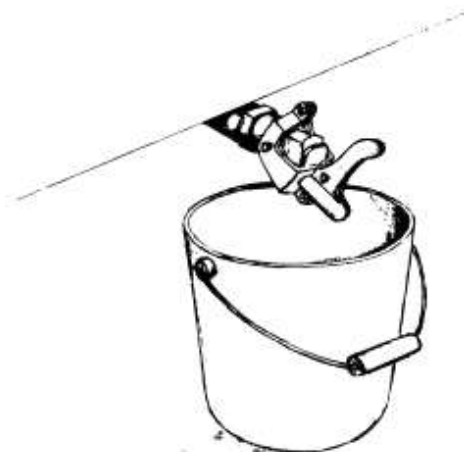

3. Remove food racks and clean thoroughly.

To remove food racks, lift left hanger and pull straight back over Rotisserie Wheel Stub. Lift right hanger and move to the left over Rotisserie Wheel Stub and washer. (Top racks simply lift out of the brackets on the hangers.)

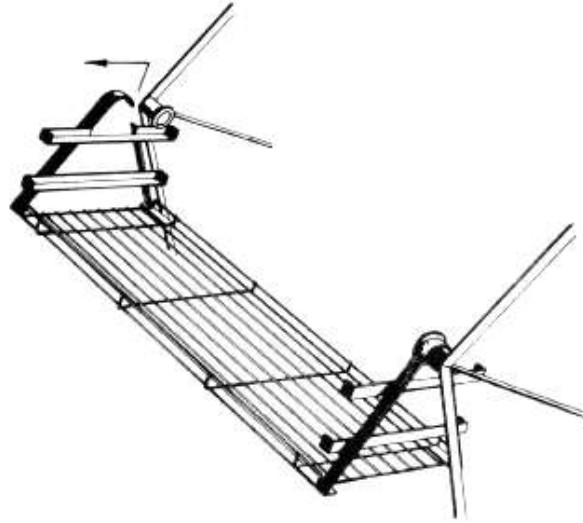

4. Thoroughly clean complete interior of pit. Use food service degreaser. Spray degreaser on the interior of the pit and allow to set for 5-10 minutes. Rinse thoroughly with water hose or pressure washer. Drain through Drain Valve.

Use Drain Pan with hose to aid in the draining of the degreaser and rinse water **while** cleaning.

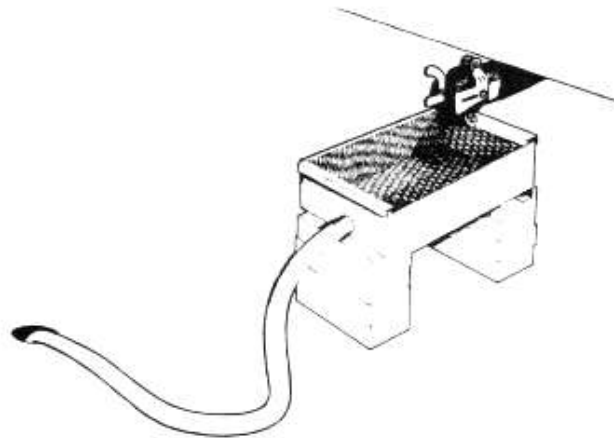

## WARNING

IT IS EXTREMELY IMPORTANT TO FOLLOW THE ABOVE **DAILY** CLEANING PROCEDURES. GREASE OR SOLIDS BUILDUP INSIDE THE PIT COULD RESULT IN A **FIRE HAZARD**.

# MAINTENANCE SCHEDULE

## WEEKLY

1. Grease Rotisserie Shaft Bearing on the left wall inside the pit.  
With a hand grease gun, put 3 full pumps into bearing.

**CAUTION:** Do not overfill bearing with grease. This could cause damage to the seals and reduce the lifetime of the bearing.

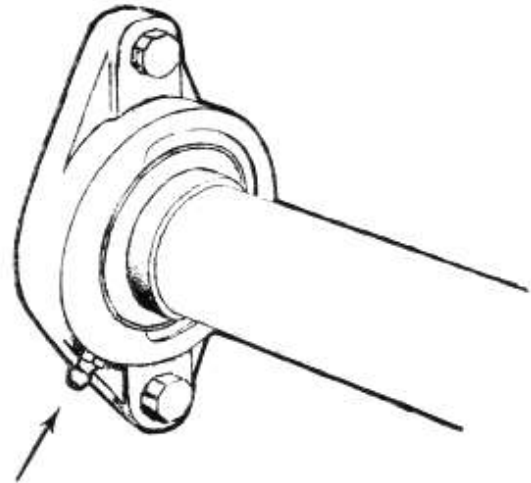

2. Grease hubs on Rotisserie Wheels.

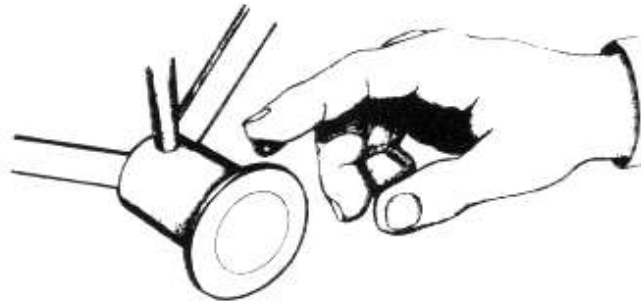

**NOTE:** (Items 1 & 2) Use Dubois FGG Extra High Temperature Food Machinery Grease with USDA "AA" Rating for incidental food contact or equivalent.

3. Inspect Burner Head for accumulation of ashes and creosote. Clean as needed.
4. Inspect Convection Fan Blade for solids buildup or out of balance condition. Clean or replace as needed.
5. Inspect Meat Loading and Firebox Door Gaskets. Replace if damaged or leaking.
6. Inspect Smoke Extractor Louver to be sure it closes completely. Clean or repair as needed.
7. Inspect the Interlock Switch to be sure the Plunger and Roller move freely. Lubricate with WD-40 or equivalent as needed.

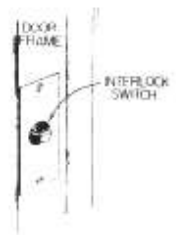

## BI-MONTHLY INTERVALS

1. The Chimney Connector and Chimney should be inspected at least twice monthly to determine if creosote buildup has occurred.

### Creosote – Formation and need for removal:

When wood is burned slowly, it produces tar and other organic vapors, which combine with expelled moisture to form creosote. The creosote vapors condense in the relatively cool chimney flue of a slow burning fire. As a result, creosote residue accumulates on the flue lining. When ignited, this creosote makes an extremely hot fire.

**IF CREOSOTE HAS ACCUMULATED IT SHOULD BE REMOVED TO REDUCE THE RISK OF A CHIMNEY FIRE.**

## 1 MONTH INTERVAL

1. Grease Drive Bearing on Gearbox. Fitting is located on right side of the Gearbox directly under the Rotisserie Motor. With a hand grease gun, put two full pumps into bearing. **DO NOT OVERFILL.**

**NOTE:** Use Dubois FGG Extra High Temperature Food Machinery Grease or equivalent.

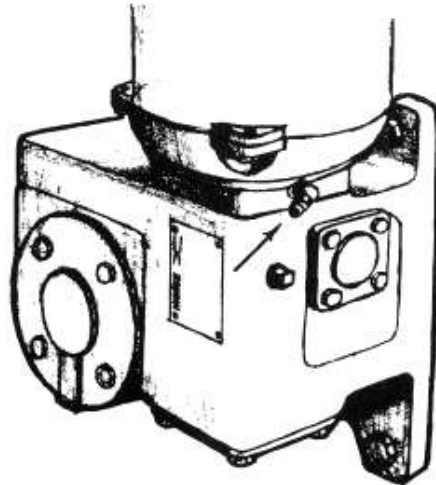

## 3 MONTH INTERVAL

1. Check the oil level in the Gearbox. To check, remove the Level Plug located on the right side of the Gearbox and see if the oil level is up to this point. If no oil is visible, add oil until overflow occurs.

**NOTE:** Use Mobil Synthetic Gear Oil SHC 634 or equivalent.

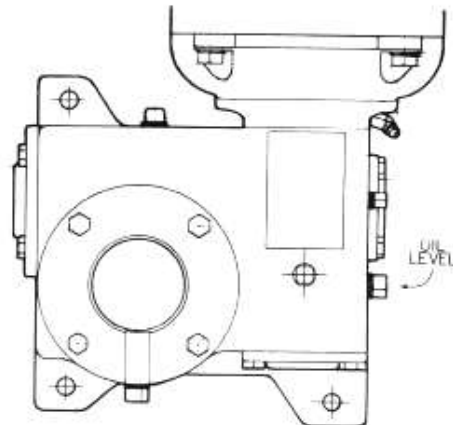

2. The Flue Pipe should be carefully inspected. Remove any solids buildup that has accumulated.

# ELECTRICAL INSTRUCTIONS

## ELECTRICAL REQUIREMENTS:

120 volts A.C., 60 hz.,  
2 wire, single phase,  
15 amp wiring required.

## WARNING:

**CHASSIS MUST BE GROUNDED TO PREVENT POSSIBLE SHOCK HAZARD. DO NOT ASSUME A PLUMBING LINE WILL PROVIDE SUCH A GROUND.**

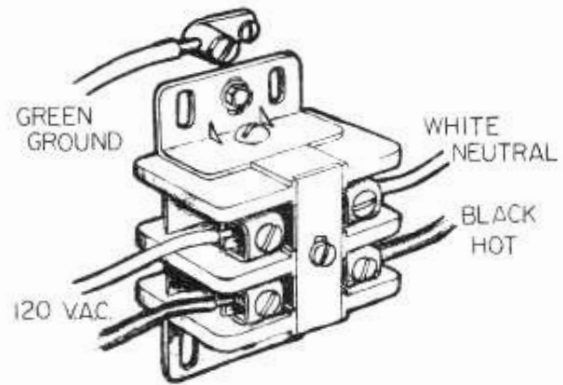

**WARRANTY IS VOID IF UNIT IS CONNECTED TO ANY VOLTAGE OTHER THAN SPECIFIED ABOVE AND ON NAMEPLATE.**

1. Electrician must provide the conduit and wire for hookup.
2. Power is to be left **OFF** throughout installation.
3. Electrical service is connected to the Terminal Block at the lower left side of the unit. Remove Front Service Door via two screws for access. A 7/8 inch diameter hole is provided in the floor for conduit connection.
4. After connecting electrical service as specified, test the voltage on the field wired side of the Terminal Block with a voltmeter. Should be 120 volts A.C.
5. Electrician must provide conduit and wire for hookup from Junction Box above the Smoke Extractor Motor on the top of the pit to the Exhaust Fan. Make electrical connections inside the Junction Box.

**NOTE:** 125 V.A.C., 1/2 hp maximum connected load, 1100 cfm fan rating recommended.

6. Replace the Service Door via two screws. If venting and gas connections have been made, the pit is now ready for "Operating Instructions." If venting or gas connections are to be done later, be sure that power is **OFF**.

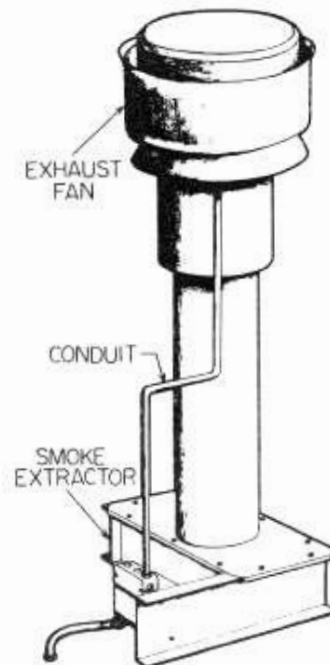

# BURNER SPECIFICATIONS

**Burner Model:** Wayne P250AF-DI

**Firing Capacity:** Maximum Input 75,000 BTU/HR

**Fuels:** Natural and L.P. Gases

**Electrical:** 120 V.A.C., 60 hz, 1 ph

**Orifice Sizes:** Natural Gas - #19 (.166)

L.P. Gas - #37 (.104)

**NOTE:** Orifice and valve setting must correlate with type of gas being supplied.

**Gas Supply Line Pressure:** Natural - 4.5" W.C. Minimum  
10.5" W.C. Maximum

L.P. - 11.0" W.C. Minimum  
13.0" W.C. Maximum

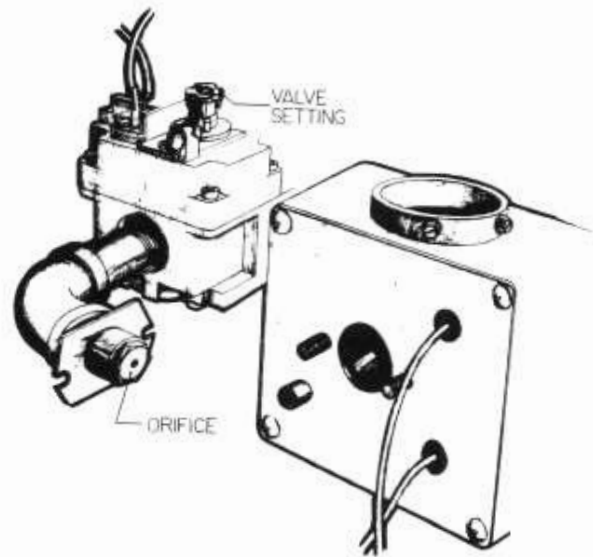
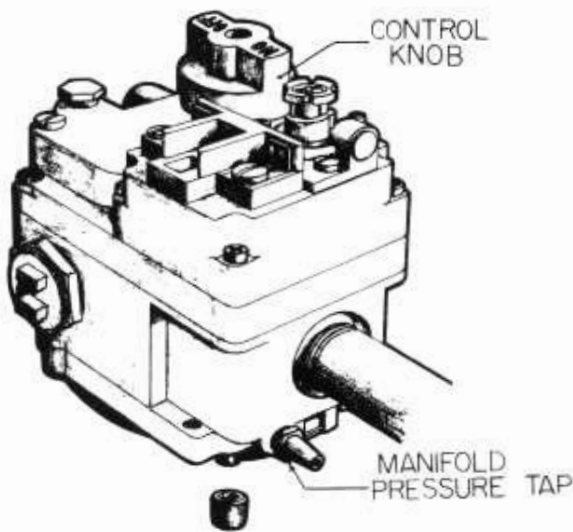

**Manifold Pressure:** Natural - 3.5" W.C.  
L.P. - 10.0" W.C.

**Gas Valve:** Control Knob **MUST** be ON.

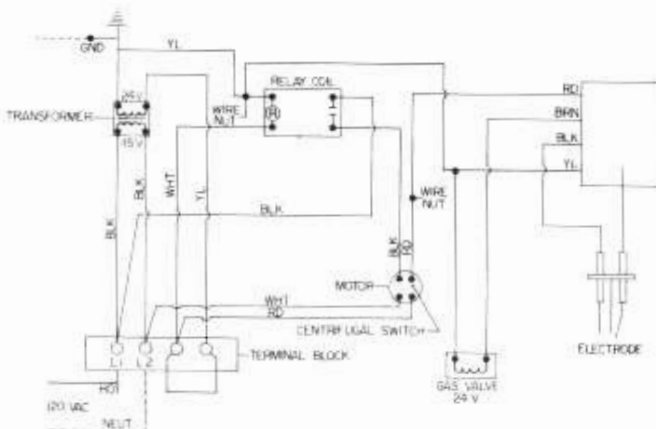

**WIRING DIAGRAM FOR GAS BURNER**

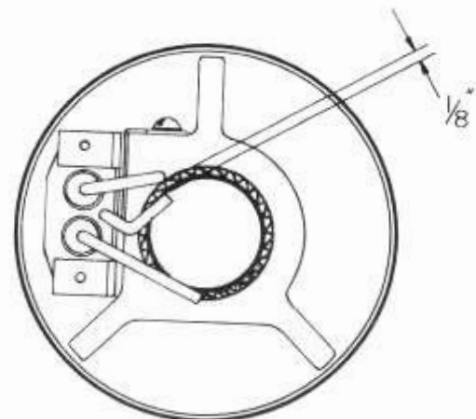

**PROPER ELECTRODE LOCATION**

## ITEMS TO CHECK BEFORE FIRING BURNER

### IMPORTANT

**WARNING: IMPROPER GAS HOOKUP WILL VOID WARRANTY AND COULD RESULT IN A HAZARDOUS CONDITION.**

---

1. Gas line **MUST** be installed by a competent technician and in accordance with this Manual.
2. Gas line **MUST** include an easily accessible manual shutoff valve, drip leg, and pressure gauge port.
3. Gas pipe size **MUST** be in accordance with the Pipe Capacity Chart in this Manual.
4. Gas line **MUST** be tested for leaks under pressure.
5. Gas Line **MUST** be purged to remove any air in the system.
6. Gas line pressure **MUST** be checked and **MUST NOT** exceed the maximum pressure specified in the Burner Specifications in this Manual.
7. Burner Orifice **MUST** correlate with the type of gas being supplied, as specified in the Burner Specifications in this Manual.

# GAS PIPING INSTRUCTIONS

1. READ ALL GAS PIPING INSTRUCTIONS CAREFULLY BEFORE MAKING GAS CONNECTIONS.

**WARNING: IMPROPER GAS HOOKUP WILL VOID WARRANTY AND COULD RESULT IN A HAZARDOUS CONDITION.**

2. Connect the gas line to the ½ inch piping that extends from the Gas Burner, through the back left panel of the unit. A ½ inch N.P.T. fitting is required.

**NOTE:** All piping must comply with local codes and ordinances of the National Fuel Gas Code ANSI Z 223.1-1974 and NFPA #54.

3. A sediment trap or drip leg must be installed in the supply line to the Burner.
4. A union shall be installed in the gas line adjacent to and upstream from the Control Manifold and downstream from the manual main shutoff valve.

Location of Union and Drip Leg.

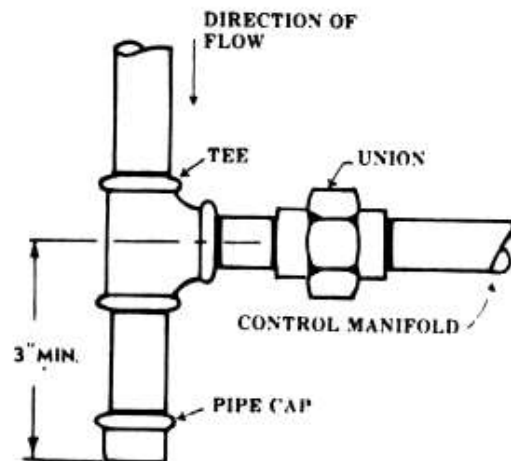

5. A 1/8 inch N.P.T. plugged tapping accessible for test gauge connection shall be installed immediately upstream of the gas supply connection for the purpose of determining the gas supply pressure to the Burner.

6. A manual shutoff valve shall be installed in the gas supply line external to the unit.

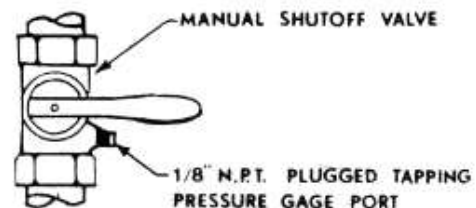

7. The gas line should be a separate supply direct from the meter to the Burner. It is recommended that a new pipe be used and located so that a minimum amount of work will be required in future servicing. The piping should be so installed as to be durable, substantial, and gas tight. It should be free from cutting burrs and defects in structure and threading. Cast iron fittings or aluminum tubing should not be used for the main gas circuit. Joint compounds (pipe dope) should be used sparingly on male threads only and be approved for all gases.

**NOTE:** The building structure should not be weakened by installation of the gas piping. The piping should not be supported by other piping, but should be firmly supported by pipe hooks, straps, bands, or hangers. Butt or lap welded pipe should not be bent.

8. The Pipe Capacity Chart must be used to determine the size pipe to use from the meter to the Burner.

PIPE SIZE	MAXIMUM LENGTH FT.	
	NAT.	LP.
3/8	—	10
1/2	10	30
3/4	70	150
1	200	250
1 1/4	250	—

**FOR GAS PRESSURES OF 0.5 PSIG OR LESS BASED ON A 0.60 AND 1.50 SPECIFIC GRAVITY GAS.**

9. **TEST PIPING FOR LEAKS.** Before turning gas under pressure into piping, all openings from which gas can escape must be closed. Immediately after turning on gas, the system should be checked for leaks. This can be done by watching the 1/2 cubic foot test dial for 5 minutes to show any movement, or by soaping each pipe connection and watching for bubbles. If a leak is found, make the necessary repairs and repeat the above test.

**NOTE:** Defective pipes or fittings should be replaced and not repaired. Never use a flame or fire of any form to locate gas leaks, use a soap solution.

10. After the piping and meter have been checked completely, **PURGE THE SYSTEM OF AIR.** Do not bleed the air inside the unit. Be sure to relight all the gas pilots on other appliances.

**NOTE:** The Burner and its individual shutoff valve must be disconnected from the gas supply piping system during any pressure testing at excess of 1/2 psig.

# VENTING INSTRUCTIONS

1. The model XLR - 350 must be vented in accordance with one of the following, A or B.

(A) Direct Venting: For direct venting, pit must be vented in accordance with the National Fire Protection Association (NFPA) standard for chimneys, fireplaces, and vents, NFPA No. 211, which requires connections of the oven to a chimney for a residential type or building heating appliances.

**NOTE:** Refer to Direct Venting Diagram on page 18.

(B) These appliances must be provided with exhaust ventilation systems in accordance with the National Fire Protection Association Standard For Removal Of Smoke And Grease Laden Vapors From Commercial Cooking Equipment, NFPA 96. Minimum vent hood size should be at least 5 ft. by 7 ft. with a minimum overhang above meat loading door of 8 inches. The lower edge of the vent hood should be located 6 ft. 6 inches from the floor. (10¼ inches from the top surface of oven)

**NOTE:** It is recommended that a local contractor be consulted regarding local codes covering wood burning and gas operated appliances before installation.

2. Provisions must be made for adequate air supply for the pit. If the pit is to be installed in a sealed room or building utilizing exhaust fans, it is recommended that the room be supplied with a return air system to eliminate negative air pressure in the room or building. Return air must be equal to or in excess of the exhausted air.

**CAUTION:** Negative air pressure on a direct vented pit will cause smoke to exit from the Draft Diverter into the room.

3. Pit must be level for proper grease drainage.

4. Minimum spacings to combustible materials:

Back - 2"  
Right side - 24" (access to firebox)  
Left side - 18" (access for service)  
Top - 18"  
Front - 48" (access for loading and unloading)  
Chimney Connector - 18"  
Smoke Extractor Chimney Connector - 18"  
Floor - May be combustible material.

**NOTE:** For flush mount, use BBR Insulation Kit #2097.

## DIRECT VENTING DIAGRAM

**NOTE:** NFPA Standards require that the chimney extend at least 3 feet above the highest side of the roof opening and be at least 2 feet higher than any portion of the building within 10 feet horizontal.

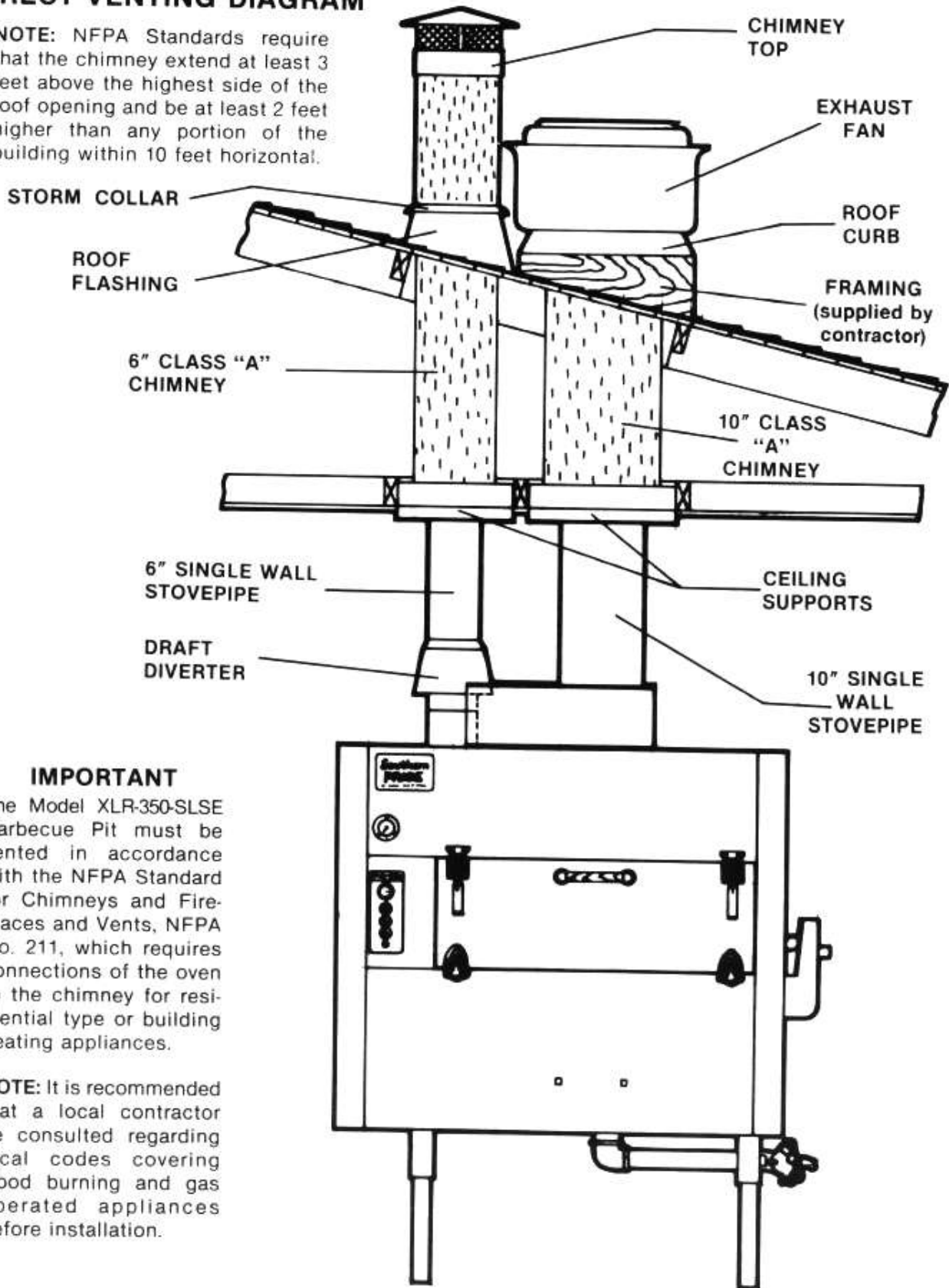

### IMPORTANT

The Model XLR-350-SLSE Barbecue Pit must be vented in accordance with the NFPA Standard for Chimneys and Fireplaces and Vents, NFPA No. 211, which requires connections of the oven to the chimney for residential type or building heating appliances.

**NOTE:** It is recommended that a local contractor be consulted regarding local codes covering wood burning and gas operated appliances before installation.

# XLR-350-SLSE WIRING

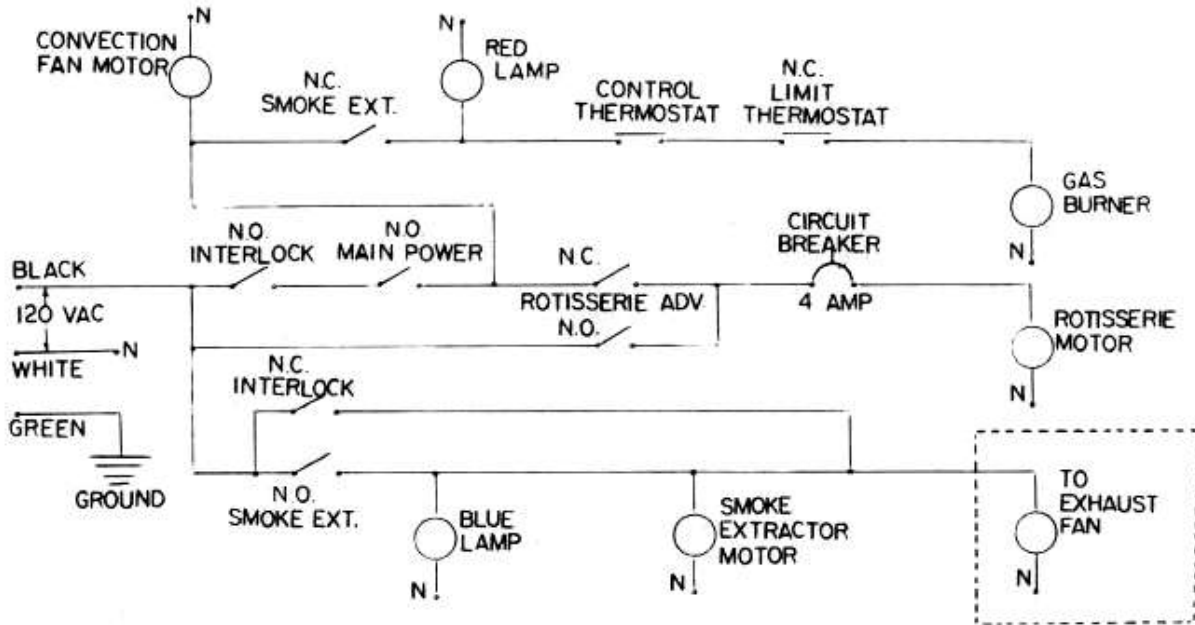

**WIRING SCHEMATIC**

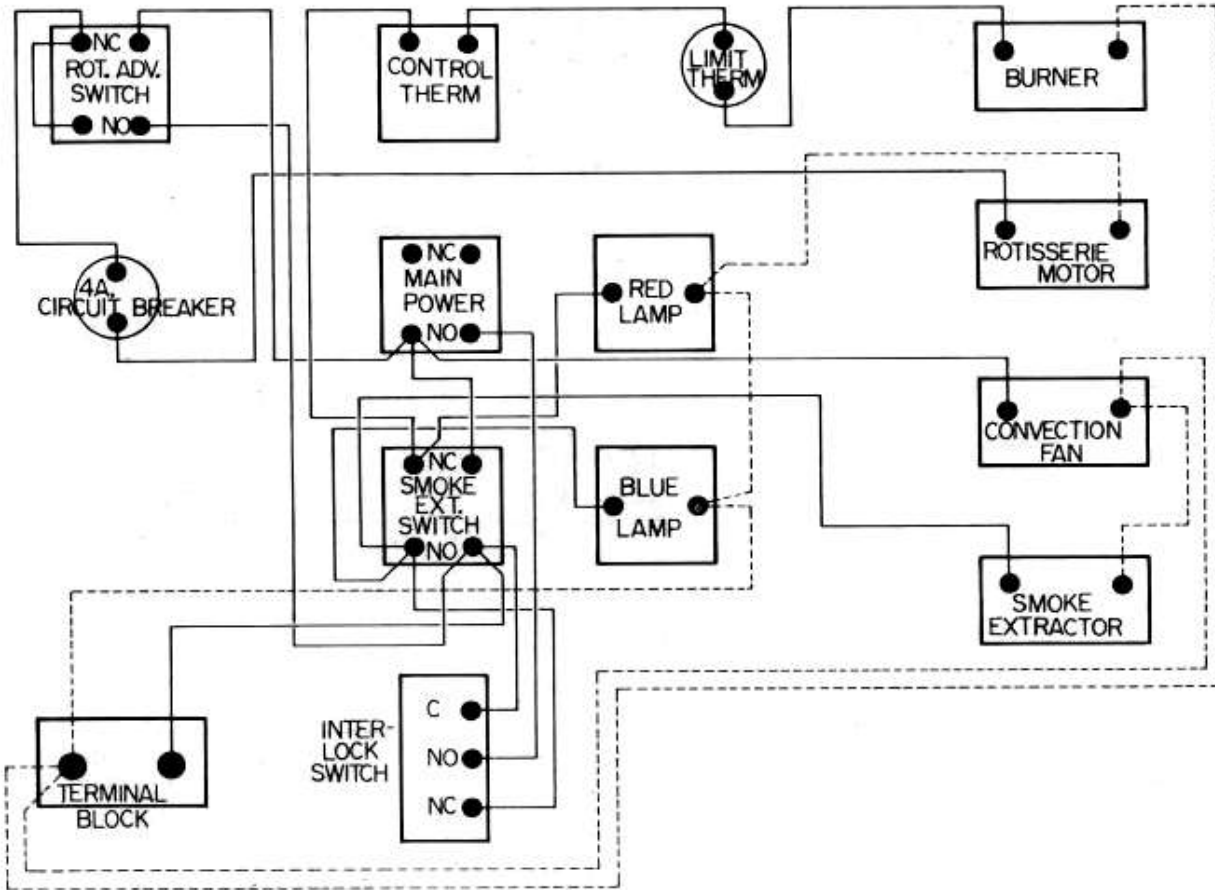

**WIRING DIAGRAM**

## 1 YEAR LIMITED WARRANTY ON SOME MODELS

(CONSULT FACTORY FOR DETAILS)

### 90 DAY LABOR WARRANTY (PRE AUTHORIZED)

Southern Pride guarantees all new equipment of its manufacture to be free of defects in material and factory workmanship for a period of one year provided that the equipment is installed in the Continental United States, Alaska, or Hawaii and operated according to the Owner's Manual while located at the original address of installation, the warranty registration card has been completed and returned to the factory within fifteen (15) days after installation and a start-up has been performed by an authorized service agent.

Southern Pride's obligation under this warranty is limited to one of the following options with the option applicable to be selected by Southern Pride at the sole discretion of Southern Pride.

1. Owner to return part, freight PREPAID, Southern Pride to repair at own expense if defective, and ship part back to owner freight collect.
2. Southern Pride to furnish replacement part, freight collect, without requesting return of the defective part.
3. Southern Pride to furnish replacement part, freight collect, in exchange for return of the defective part, freight collect.

Under certain circumstances Southern Pride will reimburse owner for limited labor costs in replacing parts during a period of not more than ninety (90) days after installation, **(provided that work is prior authorized and confirmed by Southern Pride's Service Manager.)**

Because Southern Pride does not and cannot control the owner's installation, use and maintenance of equipment manufactured by Southern Pride this warranty does not cover: any equipment installed improperly; any equipment calibrated after start-up and acceptance; any component disassembled in the field; damage due to improper cleaning, i.e. burner (hosing or "watering down" machines will cause electrical failures not covered by warranty); blown fuses, light bulbs, gaskets, electric elements and accessory components not installed or manufactured by Southern Pride. Shipping damage must be reported to the carrier and is not covered under this warranty.

Southern Pride will not be liable for damage as a result of improper installation, misuse, abuse, alteration of original design, incorrect voltage, **unauthorized service**, or breakage of fragile items, Southern Pride will not be liable for any loss or consequential damage or expense accruing directly or indirectly from the use of equipment covered by this warranty including any production or product losses or other damages which may occur as a result of equipment malfunction or failure. This warranty does not cover cooking performance, which is a function of food types, textures, temperatures and other variables chosen by the owner and over which Southern Pride has no control. The effect of corrosion, fire and normal wear on the equipment or component parts is not covered by this warranty. This warranty does not apply to damage caused by accident or to damage caused by the negligence of the owner and the employees of the owner or to damage caused by lightning generated electrical current or any other Act of God whatsoever. This warranty does not apply to any equipment bearing a serial number which has been tampered with or altered.

This warranty is exclusive and is in lieu of all other warranties, express or implied, including any implied warranty or merchantability or fitness for a particular purpose, each of which is hereby expressly disclaimed, the remedies described above are exclusive and in no event shall Southern Pride be liable for special, consequential or incidental damages for the breach or delay in performance of warranty.

## TERMS AND CONDITIONS

For purposes of definition and interpretation, the term "Seller" as used herein refers to Southern Pride and the term "Buyer" refers to the originator of a specific purchase order to Southern Pride.

Possession of a price list does not necessarily constitute an offer to sell by Southern Pride. Prices and specifications are subject to change without notice. All items will be invoiced at prices in effect at time of shipment. Equipment prices do not include federal, state, city or local taxes which may apply and all sales are subject thereto. No order, whether written or oral, shall result in a contract, unless it is accepted and acknowledged in writing by Seller at Seller's office in Marion, Illinois.

Shipping weights are approximate and all prices are quoted F.O.B. Marion, Illinois. All "common carrier" shipped equipment shall be domestic crated; all others shall be uncrated and subject to delivery charge per zone chart. Any equipment held for shipment upon Buyer's request beyond the delivery date specified on original purchase order will be due and payable within terms and will result in storage charges.

Delivery estimates are figured from date written orders are received and accepted by Seller. Seller will meet Buyer's delivery request as nearly as possible but does not guarantee shipment nor delivery on any particular date. Seller reserves right to ship merchandise via any responsible carrier. Seller's responsibility ceases upon acceptance by carrier. Buyer is expected to examine contents of shipments and immediately report any damage to carrier authorities.

Payment terms shall be 30% deposit with order; balance prior to delivery unless otherwise agreed in writing by Seller. Returns of any merchandise may not be made without Seller's written approval, prior to return. Seller shall impose a 20% restocking charge for handling of any returns. All cancellations must be in writing. Cancellations are also subject to a 20% fee.

# MODEL XLR-350-SLSE REPLACEMENT PARTS LIST

PART NUMBER	DESCRIPTION
1080	Red Main Power Switch
1082	Green Rotisserie Advance Switch
1081	Blue Smoke Extractor Switch
1068	4 amp Circuit Breaker
1003	Control Thermostat
1038	Limit Thermostat
1005	Interlock Switch
2435	Dial Thermometer
1078	Rotisserie Motor (1/8 hp)
2431	Rotisserie Gearbox
1060	Smoke Extractor Motor
1007	Gas Burner
1016	Fenwal Control Board
1069	Transformer
1070	Motor Switching Relay
1072	Gas Valve
1252	Flange Bearing
1040	Convection Fan Motor
1286	8" Fan Blade (1/2" Bore, CW)
2413	Front Door Gasket
2428	Hangers w/bottom rack
1255	Food Rack
3020	Front Door Latch
2016	Front Door Hinge
2017	Gate Valve
2433	Teflon Axle Seal
1294	Ash Tote
5036	Ash Scraper
322	Mobil Synthetic Worm Gear Oil SHC 634
304	Dubois FGG Extra High Temp. Food Machinery Grease