

**Southern  
PRIDE**

WOOD BURNING BBQ PITTS & SMOKERS

**MODEL BMJ-350-I**

**INSTRUCTION MANUAL**

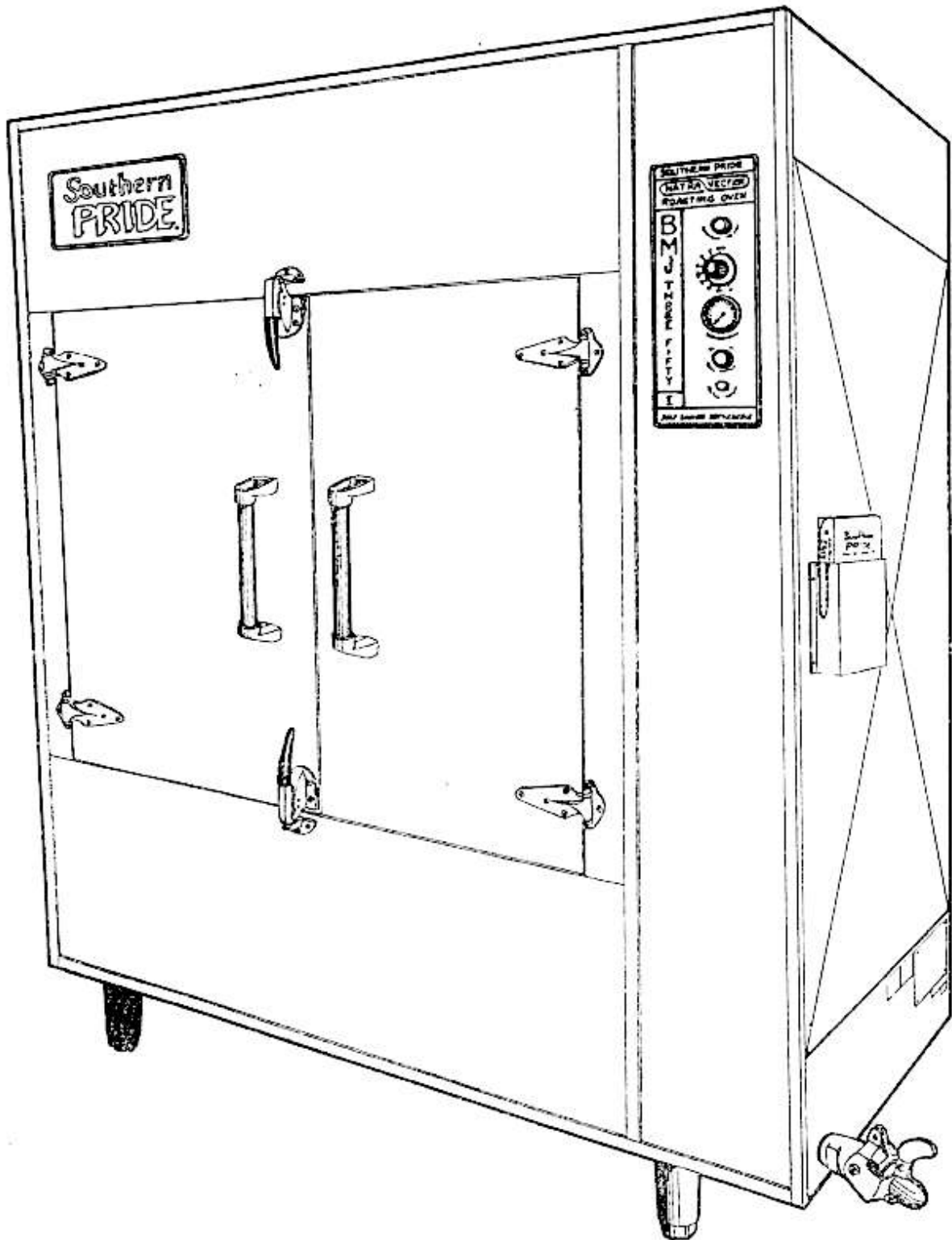

# ★ ★ ★ CONGRATULATIONS ★ ★ ★

In selecting your **SOUTHERN PRIDE** Model BMJ-350-I "NATRA-VECTION" Roasting Oven, you have chosen the most innovative, compact, efficient and fully automatic multi-purpose roasting oven available. The Model BMJ-350-I is the result of the highest quality construction, tested and inspected under rigid quality control standards to assure trouble free operation and reliability. At **B.B. ROBERTSON COMPANY**, it's a matter of pride . . . . **SOUTHERN PRIDE**.

Please read this **INSTRUCTION MANUAL** carefully prior to installation and operation. Proper installation, operation, cleaning, and maintenance are essential for your satisfaction and safe operation.

## KEEP THIS MANUAL FOR REFERENCE

### TABLE OF CONTENTS

	Page
Safety Information . . . . .	1-2
Diagram of Controls & Components . . . . .	3-4
Operating Instructions . . . . .	5-6-7
Cleaning Instructions . . . . .	8-9
Maintenance Schedule . . . . .	10-11
Installation Instructions	
Electrical . . . . .	12
Burner Specifications . . . . .	13-14
Items to Check Before Firing Burner . . . . .	15
Gas Piping . . . . .	16
Venting . . . . .	17
Venting Diagram . . . . .	18
Wiring Schematic . . . . .	19
Wiring Diagram . . . . .	19
Limited Warranty . . . . .	20
Replacement Parts List . . . . .	21

# SAFETY INFORMATION

## FOR YOUR SAFETY

### IF YOU SMELL GAS . . . . .

1. Open Windows.
2. Do not touch electrical switches.
3. Extinguish any open flames.
4. Immediately call your gas supplier.

**DO NOT STORE OR USE GASOLINE OR OTHER FLAMMABLE VAPORS OR LIQUIDS IN THE VICINITY OF THIS OR ANY OTHER APPLIANCES.**

1. The oven area **MUST** be kept clear and free of combustible materials, gasoline and other flammable vapors and liquids.
2. The flow of combustion and ventilating air **MUST NOT** be obstructed from reaching the oven.
3. The frame of the oven **MUST** be electrically grounded at all times. See "Electrical Instructions" in this manual.

### **FAILURE TO GROUND THIS UNIT MAY RESULT IN AN ELECTRICAL SHOCK.**

4. Caution should be used when opening and closing the Firebox Door located inside the oven. The door is **HOT** during operation.
5. **DO NOT** remove service compartment access panels when unit is in operation or leave off during operation.
6. Gas burners require the services of an experienced technician for proper setting and adjustment. If the burner does not appear to be operating properly, **DO NOT ATTEMPT TO ADJUST THE BURNER YOURSELF**, but call in a competent serviceman or contact B.B. Robertson Co.
7. **DO NOT** allow unqualified personnel to perform service work or adjustments on this unit. To do so, will **VOID WARRANTY** and could result in a hazardous condition.
8. Be sure any new employees, who might operate this oven, are instructed on operation and safety information prior to operating the oven.
9. Caution: Ashes removed from the Firebox should be stored in a non-combustible container with a sealed lid only. Store in a well ventilated area. **FUMES COULD BE HAZARDOUS.**
10. **WARNING: IT IS EXTREMELY IMPORTANT TO FOLLOW DAILY CLEANING INSTRUCTIONS. EXCESS GREASE OR SOLIDS BUILD UP INSIDE THE OVEN COULD RESULT IN A FIRE HAZARD.**
11. **KEEP THIS INSTRUCTION MANUAL FOR REFERENCE.**

## **CAUTION**

### **DO NOT OPERATE OVEN UNDER ANY OF THE FOLLOWING CONDITIONS:**

1. **DO NOT** operate oven unless the Firebox Door and Oven Doors are secured in the closed position.
2. **DO NOT** leave Firebox Door or Meat Loading Door open while oven is unattended.
3. **DO NOT** use aluminum foil or any other protective material on inner liner surfaces or food racks of oven.
4. **DO NOT** operate oven unless daily cleaning procedures have been performed to remove grease and solids build-up inside the oven.
5. **DO NOT** operate oven unless operator has been thoroughly trained on operation, safety and cleaning procedures.
6. **DO NOT** open Drain Valve while oven is in operation or while burning wood and hot coals are still in Firebox.
7. **DO NOT** operate oven if Gaskets on Oven Doors are damaged or missing.
8. **DO NOT** operate oven or leave burning wood or coals in Firebox unless vent hood is on.

## **WARNING**

**FAILURE TO OBSERVE THESE WARNINGS COULD RESULT IN A HAZARDOUS CONDITION.**

# SOUTHERN PRIDE'S BMJ-350-I

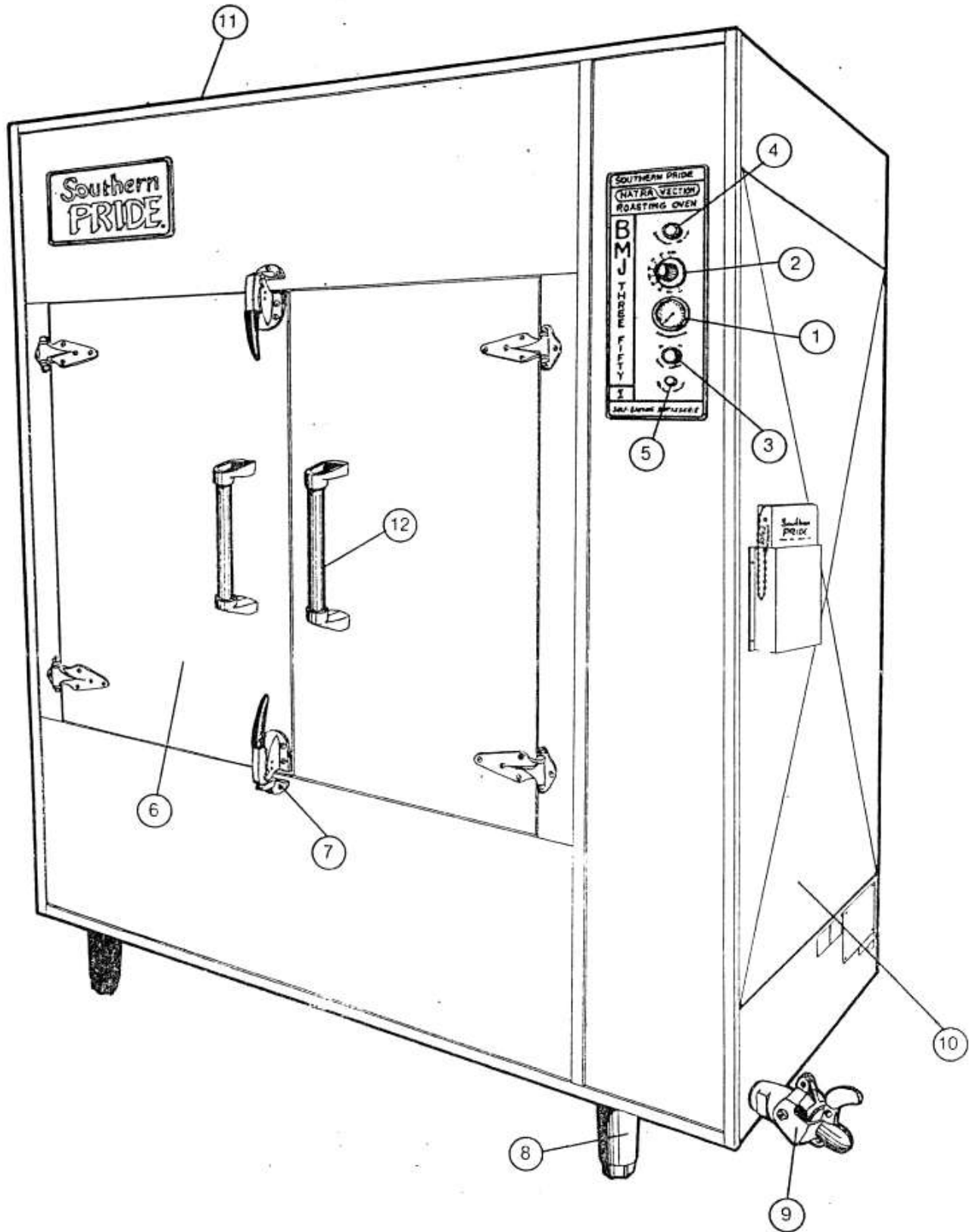

# **BMJ-350-I CONTROLS AND COMPONENTS**

1. **DIAL THERMOMETER** – Shows at a glance the interior temperature of the oven.
2. **CONTROL THERMOSTAT** – Adjustable temperature setting (100-325°F) with OFF position. Maintains desired oven temperature by controlling the Gas Burner.
3. **MAIN POWER SWITCH** – Activates the Rotisserie, Gas Burner, and Red Indicator Lamp. (The Red Indicator Lamp on the Main Power Switch indicates when the switch is ON.)
4. **ROTISSERIE ADVANCE SWITCH** – Momentarily activates Rotisserie to advance the food racks for loading and unloading when Oven Doors are open or Main Power Switch is OFF.
5. **CIRCUIT BREAKER** – Provides protection for the Rotisserie Drive Motor.
6. **OVEN DOORS** – For access to Food Racks and oven interior.
7. **OVEN DOOR LATCHES** – Latches apply positive pressure and seals oven doors.
8. **CABINET LEGS** – Provides adjustment for leveling of the oven.
9. **DRAIN VALVE** – Is opened after each cooking to drain grease.
10. **SERVICE PANEL** – Provides access to Rotisserie Drive System, Controls, Wiring, and Gas Burner.
11. **FLUE OUTLET** – Flue opening to be vented into vented hood.
12. **OVEN DOOR PULL HANDLES** – For opening and closing oven doors. (Pull handles stay cool.)
13. **HEAT SHIELD DOORS** – (not shown) Located in the lower half of the door opening. Removable doors shield the operator from the heat of the Firebox. Doors help retain heat while loading and unloading product.

## OPERATING INSTRUCTIONS

1. Load meat on the food racks. Always load bottom rack first and distribute the weight evenly on all five sets of food racks. **DO NOT LET THE MEAT EXTEND BEYOND OR HANG OVER THE EDGE OF THE RACKS.**

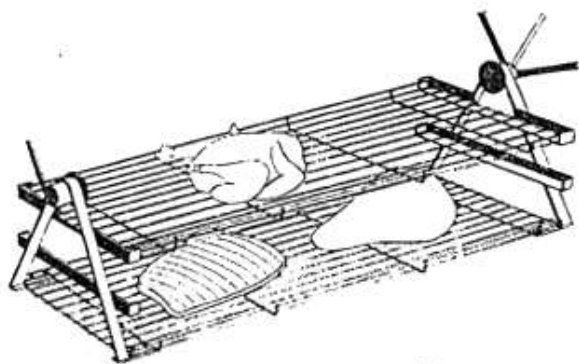

### CORRECT

Load meat on bottom rack first.

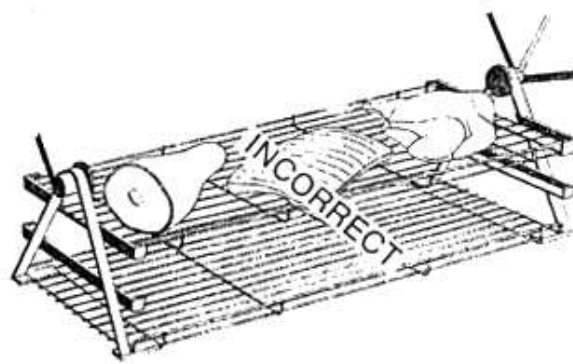

### WRONG

May cause food racks to tip and meat to fall. This could cause the Rotisserie to jam.

2. To advance the racks with the Oven Doors open, depress the Rotisserie Advance Switch until the racks advance to the next position.
3. After the meat is loaded, depress Rotisserie Advance Switch and allow Rotisserie to make one complete revolution. Check meat clearances to cabinet and all racks. Reposition meat on racks for maximum clearances.
4. **FOR BARBECUE PRODUCTS ONLY:** Put one fireplace size log in firebox. Use one log only, 4-6 inches in diameter, 12-15 inches long. Use green or slightly seasoned hardwoods only.

**CAUTION: DO NOT USE DRY WOOD OR KINDLING.**

DO NOT OVERLOAD FIREBOX. TOO MUCH WOOD CAN CAUSE OVERHEATING OF THE OVEN.

COALS AND ASHES FROM PREVIOUS COOKING MUST BE REMOVED BEFORE LOADING WOOD.

DO NOT ALLOW ASHES IN OR NEAR THE BURNER OPENING. KEEP ALL LOGS AT LEAST 6 INCHES FROM THE BURNER.

FIREBOX DOOR MUST BE CLOSED COMPLETELY BEFORE OUTER DOOR IS CLOSED.

To open Firebox Door, place Firebox Opener in bracket hole and pull straight back. **CAUTION:** Firebox is hot during operation.

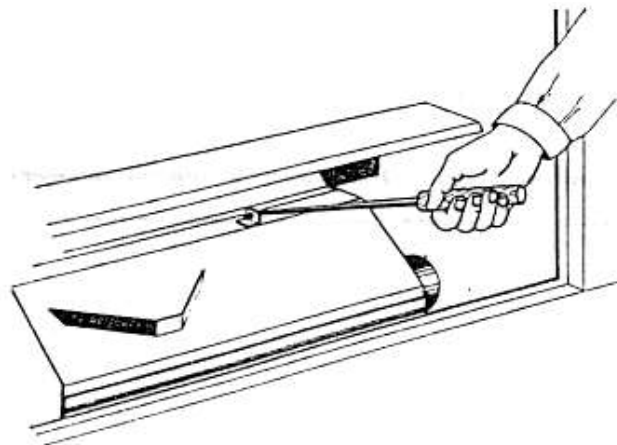

Correct way to load wood. Use one fireplace size hardwood log, 4-6 inches in diameter; 12-15 inches long.

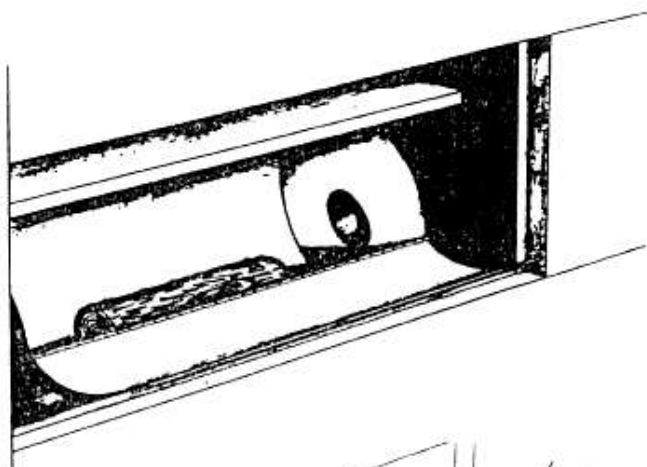

Use Ash Scoop to remove ashes and coals from Firebox.

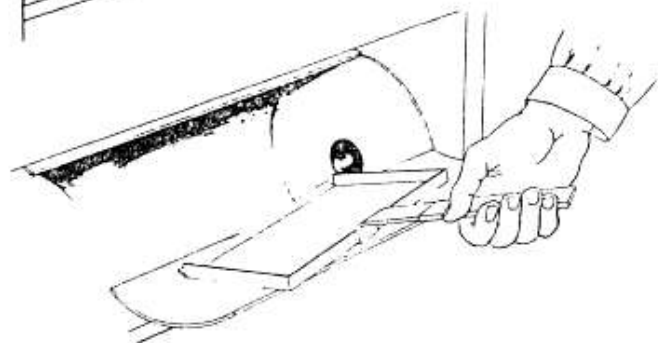

5. Be sure Firebox Door and Oven Doors are secured in the closed position.
6. Set the Control Thermostat to the desired temperature setting.
7. Turn the Main Power Switch to the **ON** position. The Burner will be ignited and cooking temperature will be maintained automatically. (The red indicator lamp on the Main Power Switch indicates when the switch is **ON**.)
8. When the meat is cooked, turn the Main Power Switch to the **OFF** position. To unload food racks, depress the Rotisserie Advance Switch until the racks advance to an unloading position.  
**NOTE:** To check or unload meat when cooking with wood, open oven doors slowly to allow excess smoke to be directed into vent hood.
9. To utilize as a **HOLDING OVEN**, simply set the control thermostat to the desired holding temperature. Holding temperature will be maintained automatically.
10. To utilize as a **MEDIUM TEMPERATURE BAKING OVEN**, ½ size steam table pans may be used on the food racks. Load pans on food racks as illustrated.

**CAUTION:** Always load pans on bottom rack first and distribute the weight evenly on all five sets of food racks.

**DO NOT** use pans larger than ½ size steam table pans.

**DO NOT** use 6" deep pans on top food rack.

**DO NOT** let pans extend beyond or hang over the edge of the racks.

After pans are loaded, **ALWAYS** depress Rotisserie Advance Switch and allow Rotisserie to make one complete revolution. Check pan clearances to cabinet and all racks. Re-position pans on racks for maximum clearances.

### CORRECT WAY TO LOAD PANS

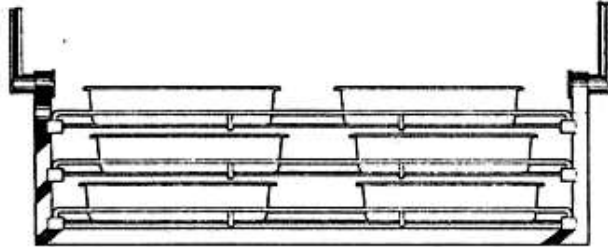

2½" deep pans

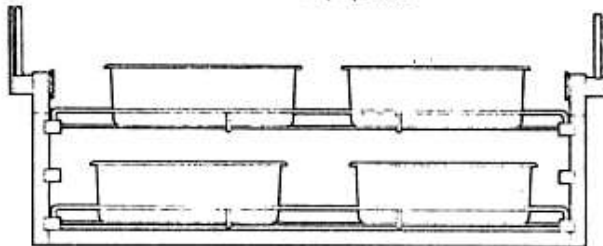

4" deep pans

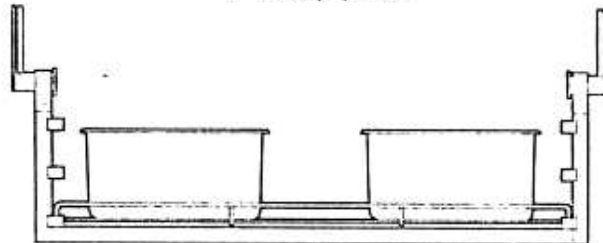

6" deep pans

### WRONG

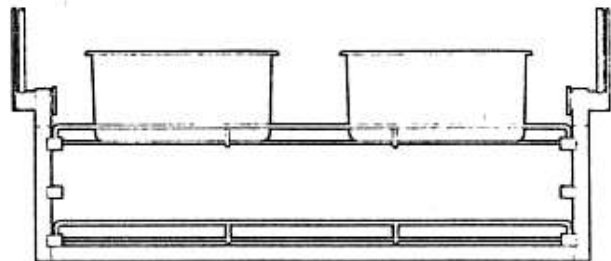

**WRONG:** Too much weight on the top may cause food racks to tip and pans to fall. This could cause the Rotisserie to jam.

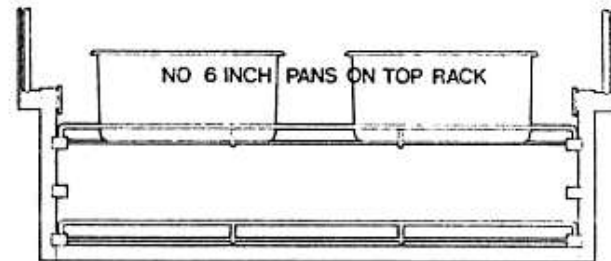

**WRONG:** DO NOT use 6" deep pans on TOP FOOD RACK.

11. After each cooking, open Drain Valve and drain grease from the Grease Pan while oven is still warm. If wood has been used, **BE SURE TO** remove the remaining wood and hot coals from Firebox before opening Drain Valve.

**CAUTION:** BE SURE FIREBOX DOOR AND OVEN DOORS ARE SECURED IN THE CLOSED POSITION IMMEDIATELY FOLLOWING A COOKING AND DURING NON-USE PERIODS.

BE SURE VENT HOOD IS ON WHILE OVEN IS IN OPERATION AND AS LONG AS WOOD AND HOT COALS REMAIN IN FIREBOX.

DO NOT OPEN DRAIN VALVE WHILE OVEN IS IN OPERATION OR WHILE BURNING WOOD AND HOT COALS ARE STILL IN FIREBOX.

### IMPORTANT

The Gas Burner is equipped with an automatic ignition system. To ignite, turn the Main Power Switch to the ON position and set control Thermostat to desired temperature. To shut Burner OFF, turn the Main Power Switch to the OFF position.

# CLEANING INSTRUCTIONS

1. If wood has been used, remove ashes and coals from Firebox after each cooking. (Be sure hot coals and wood are removed from the Firebox before opening Drain Valve.)

**ASH DISPOSAL:** Ashes should be placed in a non-combustible container with a tight fitting lid. The closed container of ashes should be placed on a non-combustible floor well away from all combustible material, pending final disposal.

Use Ash Scoop to remove ashes and coals from Firebox.

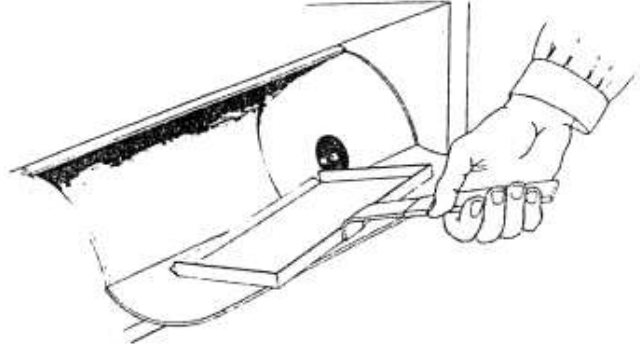

Place ashes and coals in a non-combustible container with a tight fitting lid.

**CAUTION:** Fumes could be hazardous.

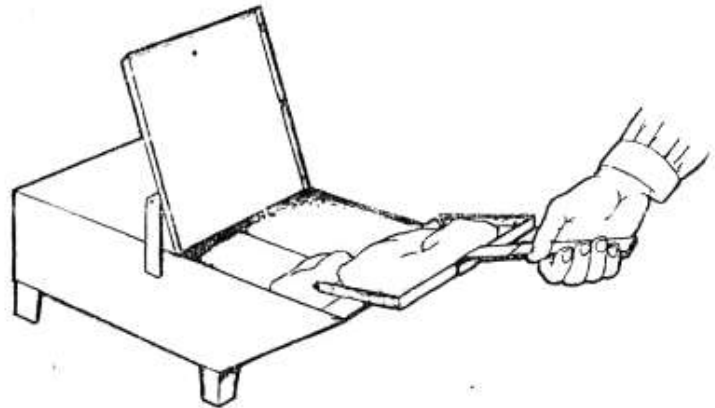

2. Drain Grease.

Open Drain Valve and drain Grease Pan.

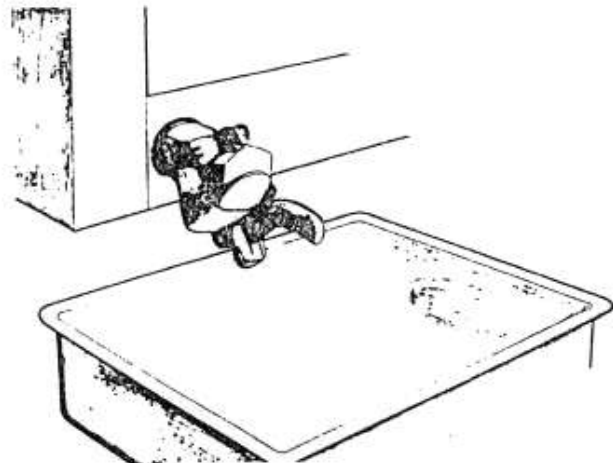

3. Remove food racks and clean thoroughly. Food racks simply lift out of the brackets on the hangers.

To remove Food Rack Hangers, lift left hanger and pull straight back over Rotisserie Wheel Stub. Lift right hanger and move to the left, over Rotisserie Wheel Stub and washer.

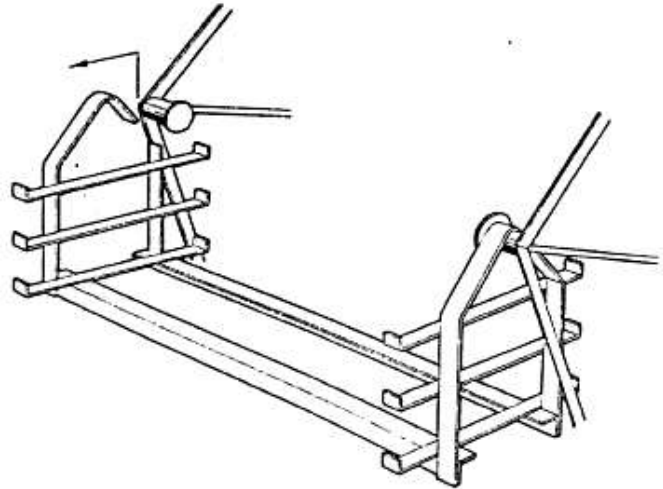

4. The porcelain-coated baffle board can be lifted upward for easy cleaning.
5. Thoroughly clean complete interior of oven. Use food service degreaser. Spray degreaser on the interior of the oven and allow to set for 5-10 minutes. Rinse thoroughly with water hose or pressure washer.

Use Drain Pan with hose to aid in the draining of the degreaser and rinse water while cleaning.

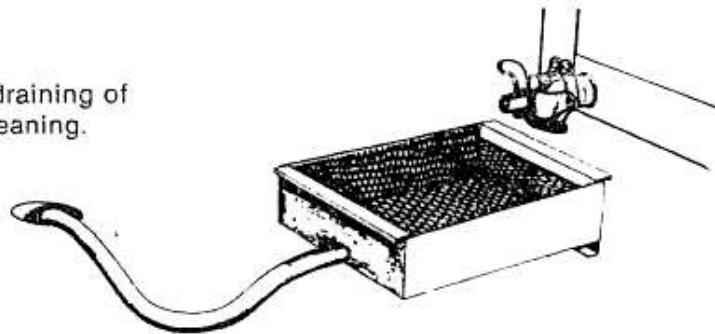

## WARNING

IT IS EXTREMELY IMPORTANT TO FOLLOW THE ABOVE **DAILY** CLEANING PROCEDURES. GREASE OR SOLIDS BUILDUP INSIDE THE OVEN COULD RESULT IN A **FIRE HAZARD**.

# MAINTENANCE SCHEDULE

## WEEKLY

1. Grease Rotisserie Shaft Bearing on the left wall inside the pit. With a hand grease gun, put 3 full pumps into bearing.

**CAUTION:** Do not overfill bearing with grease. This could cause damage to the seals and reduce the lifetime of the bearing.

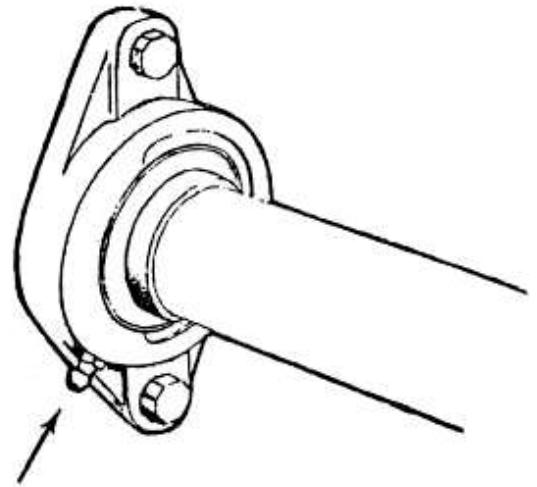

2. Grease hubs on Rotisserie Wheels.

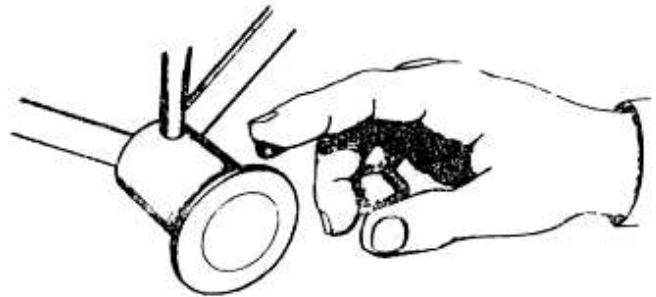

**NOTE:** (Items 1 & 2) Use Dubois FGG Extra High Temperature Food Machinery Grease with USDA "AA" Rating for incidental food contact or equivalent.

3. Inspect Burner Head for accumulation of ashes and creosote. Clean as needed.
4. Inspect Meat Loading Door Gaskets. Replace if damaged or leaking.

## 1 MONTH INTERVAL

1. Grease Drive Bearing on Gearbox. Fitting is located on top side of the Gearbox. With a hand grease gun, put two full pumps into bearing. **DO NOT OVERFILL.**

**NOTE:** Use Dubois FGG Extra High Temperature Food Machinery Grease or equivalent.

## 3 MONTH INTERVAL

1. Check the oil level in the Gearbox. To check, remove the Level Plug located on the left side of the Gearbox and see if the oil level is up to this point. If no oil is visible, add oil until overflow occurs.

**NOTE:** Mobil Synthetic Gear Oil SHC 634 or equivalent.

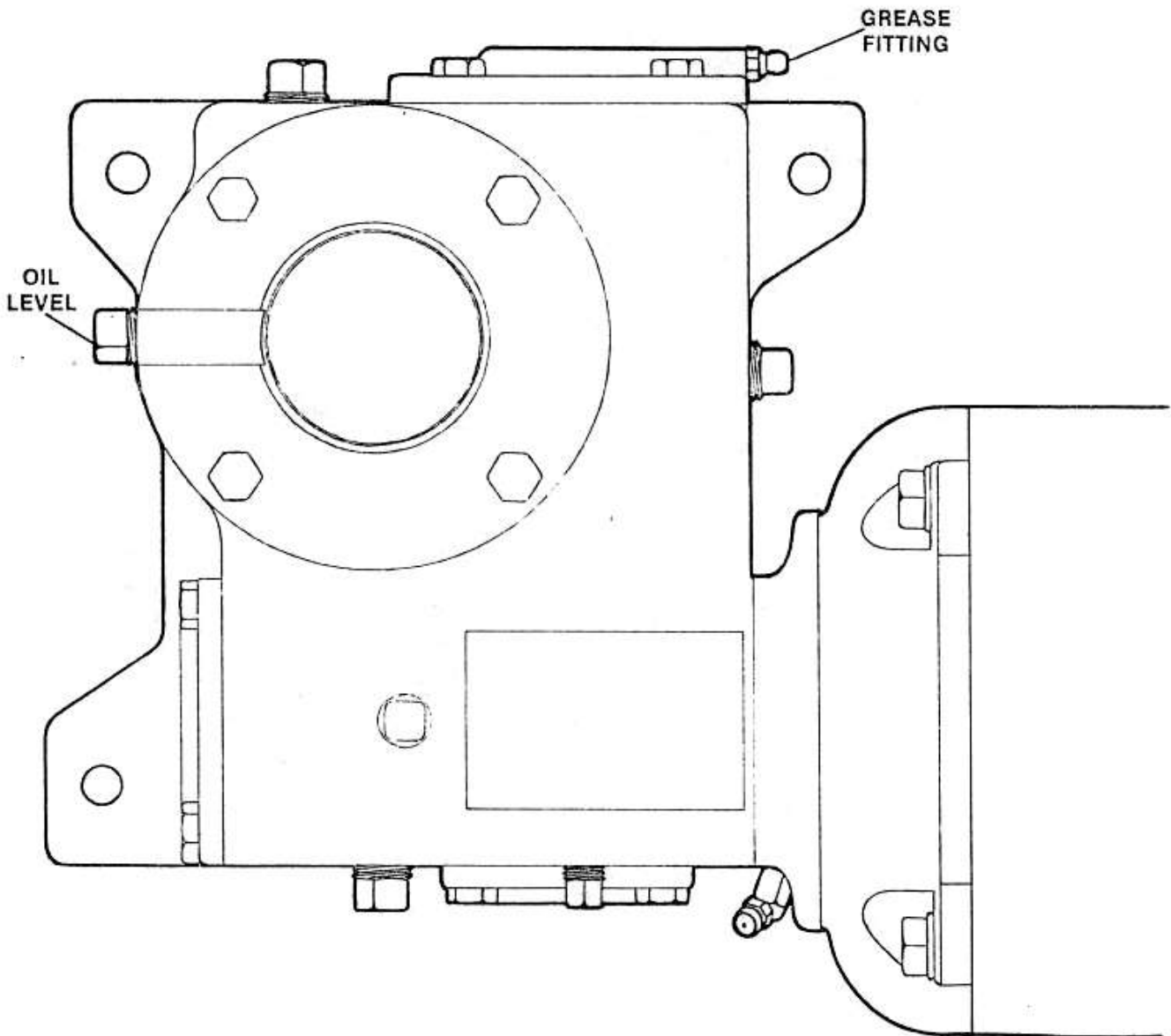

# ELECTRICAL INSTRUCTIONS

## ELECTRICAL REQUIREMENTS:

120 volts A.C., 60 hz.,  
2 wire, single phase,  
15 amp wiring required.

## WARNING:

CHASSIS MUST BE GROUNDED TO  
PREVENT POSSIBLE SHOCK HAZARD.  
DO NOT ASSUME A PLUMBING LINE  
WILL PROVIDE SUCH A GROUND.

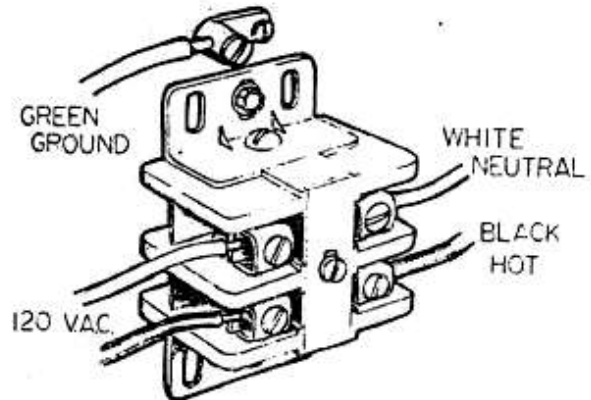

WARRANTY IS VOID IF UNIT IS CONNECTED TO ANY VOLTAGE OTHER THAN SPECIFIED ABOVE AND ON NAMEPLATE.

1. Electrician must provide the conduit and wire for hookup.
2. Power is to be left **OFF** throughout installation.
3. Electrical service is connected to the Terminal Block at the lower right rear of the unit. Remove Service Door via four screws for access. A 7/8 inch diameter hole is provided in the back panel for conduit connection.
4. After connecting electrical service as specified, test the voltage on the field wired side of the Terminal Block with a voltmeter. Should be 120 volts A.C.
5. Replace the Service Door via four screws. If venting and gas connections have been made, the oven is now ready for "Operating Instructions." If venting or gas connections are to be done later, be sure that power is **OFF**.

# BURNER SPECIFICATIONS

**Burner Model:** Wayne P250 AF-EP

**Firing Capacity:** Maximum Input 75,000 BTU/HR

**Fuels:** Natural and L.P. Gases

**Electrical:** 120 V.A.C., 60 HZ, 1 PH

**Gas Supply Line Pressure:** Natural - 4.5" W.C. Minimum  
10.5" W.C. Maximum                      L.P. - 11.0" W.C. Minimum  
13.0" W.C. Maximum

**NOTE:** To check gas supply line pressure:

1. Turn **OFF** Manual Shut Off Valve located on gas line inside component compartment.
2. Remove pressure tap plug from outlet end of shut off valve and connect pressure gauge (Manometer).
3. Turn **ON** Manual Shut Off Valve and read pressure gauge. If reading is within the above recommended line pressure, cycle the burner several times to be sure line pressure is maintained when burner in **ON**.
4. If reading exceeds the above recommended line pressure, turn **OFF** Manual Shut Off Valve and contact the gas supplier immediately. **DO NOT ATTEMPT TO OPERATE OVEN OR CYCLE BURNER.**
5. Turn **OFF** Manual Shut Off Valve. Remove pressure gauge and replace pressure tap plug.

**MANIFOLD PRESSURE:**

Natural Gas - 3.0" W.C. Minimum  
3.5" W.C. Maximum                      L.P. Gas - 9.5" W.C. Minimum  
10.0" W.C. Maximum

**NOTE:** To check manifold pressure:

1. Turn Main Power Switch to **OFF** position.
2. Remove pressure tap plug from outlet and of Gas Valve and connect pressure gauge (Manometer).
3. Cycle burner on and off several times to stabilize PRV diaphragm. (This must be done before an accurate pressure reading can be obtained).
4. With burner **ON**, read pressure gauge. If reading does not conform to above recommended manifold pressure, a limited adjustment of the PRV may be made. Remove PRV cap screw and turn PRV adjusting screw clockwise → to increase or counterclockwise ← to decrease manifold pressure.
5. Turn Main Power Switch to **OFF** position. Remove pressure gauge and replace pressure tap plug and PRV cap screw.

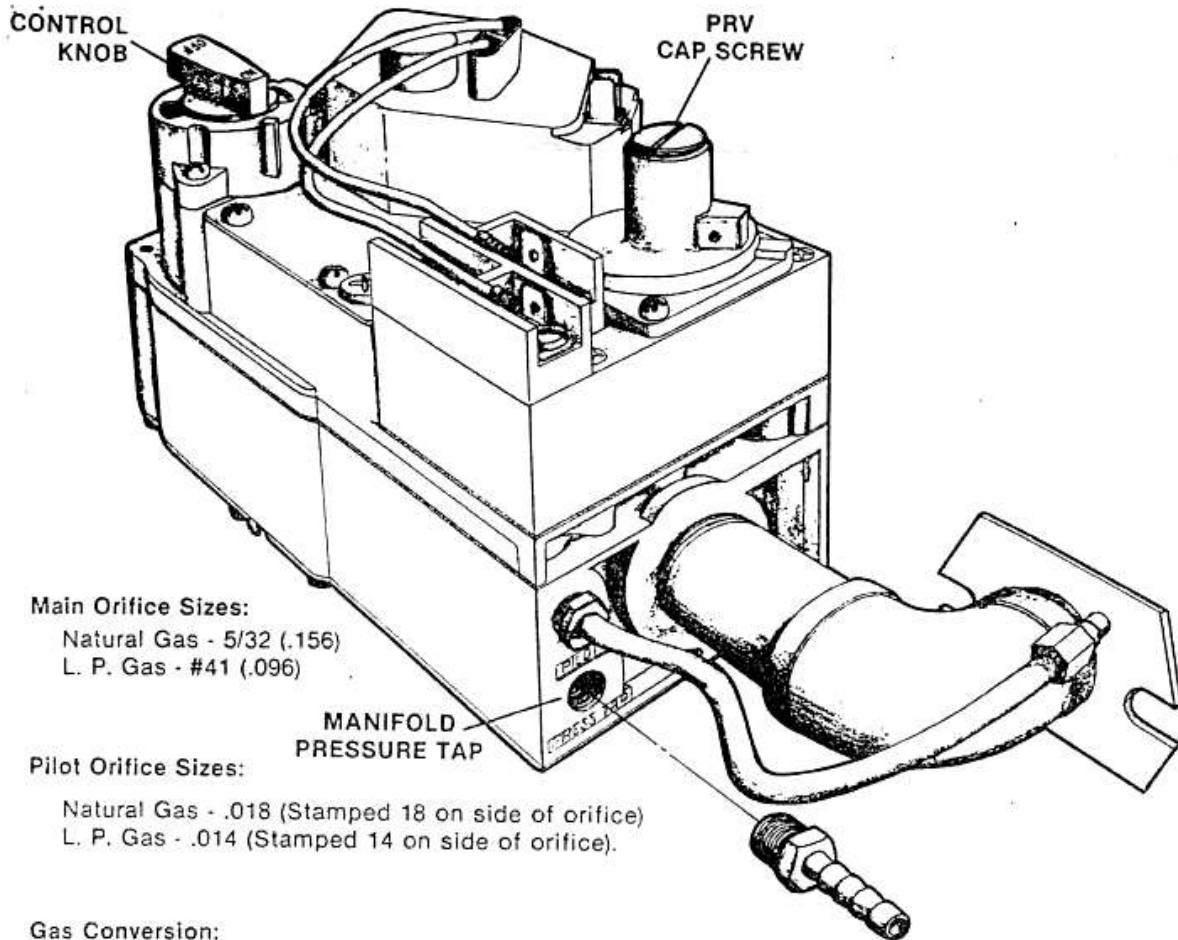

Main Orifice Sizes:  
 Natural Gas - 5/32 (.156)  
 L. P. Gas - #41 (.096)

Pilot Orifice Sizes:  
 Natural Gas - .018 (Stamped 18 on side of orifice)  
 L. P. Gas - .014 (Stamped 14 on side of orifice).

**Gas Conversion:**

To convert the burner to type of gas other than specified on the B.B. Robertson Company Nameplate, **USE ONLY** Burner Conversion kits supplied by B.B. Robertson Company.

(For conversion from L.P. to Natural, use BBR# 3019 Conversion Kit).

(For conversion from Natural to L.P., use BBR# 3029 Conversion Kit).

**GAS VALVE:** Control knob must be ON.

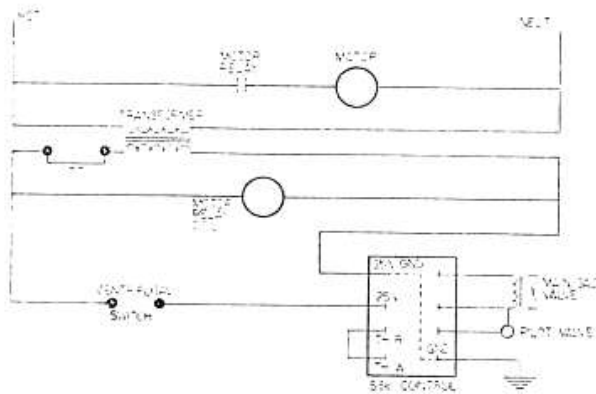

Burner Wiring Diagram

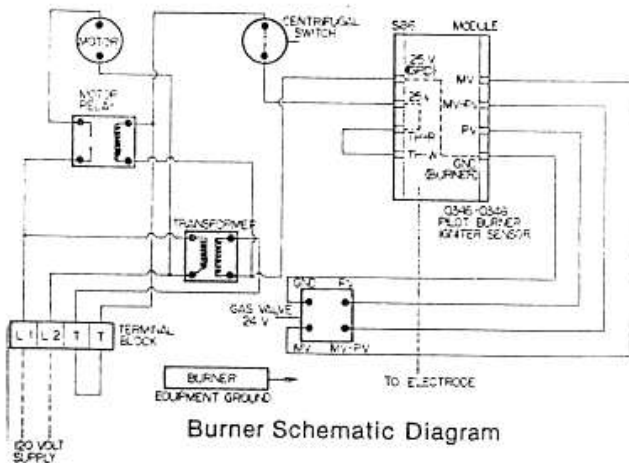

Burner Schematic Diagram

## ITEMS TO CHECK BEFORE FIRING BURNER

### IMPORTANT

**WARNING: IMPROPER GAS HOOKUP WILL VOID WARRANTY AND COULD RESULT IN A HAZARDOUS CONDITION.**

1. Gas line **MUST** be installed by a competent technician and in accordance with this Manual.
2. Gas pipe size **MUST** be in accordance with the Pipe Capacity Chart in this Manual.
3. Gas line **MUST** be tested for leaks under pressure.
4. Gas Line **MUST** be purged to remove any air in the system.
5. Gas line pressure **MUST** be checked and **MUST NOT** exceed the maximum pressure specified in the Burner Specifications in this Manual.
6. Gas supply **MUST** correlate with the type of gas specified on the B.B. Robertson Company Nameplate.

# GAS PIPING INSTRUCTIONS

1. READ ALL GAS PIPING INSTRUCTIONS CAREFULLY BEFORE MAKING GAS CONNECTIONS.

**WARNING: IMPROPER GAS HOOKUP WILL VOID WARRANTY AND COULD RESULT IN A HAZARDOUS CONDITION.**

2. Connect the gas line to the ½ inch piping that extends from the Gas Burner, through the back right panel of the unit. A ½ inch N.P.T. fitting is required.

**NOTE:** A drip leg, union, regulator and manual shut off valve, with a 1/8" N.P.T. Plugged Tapping Pressure Port, are supplied with the unit and located inside component compartment.

3. The gas line should be a separate supply direct from the meter to the Burner. It is recommended that a new pipe be used and located so that a minimum amount of work will be required in future servicing. The piping should be so installed as to be durable, substantial, and gas tight. It should be free from cutting burrs and defects in structure and threading. Cast iron fittings or aluminum tubing should not be used for the main gas circuit. Joint compounds (pipe dope) should be used sparingly on male threads only and be approved for all gases.

**NOTE:** The building structure should not be weakened by installation of the gas piping. The piping should not be supported by other piping, but should be firmly supported by pipe hooks, straps, bands, or hangers. Butt or lap welded pipe should not be bent.

4. The Pipe Capacity Chart must be used to determine the size pipe to use from the meter to the Burner.

## PIPE CAPACITY CHART

PIPE SIZE	MAXIMUM LENGTH FT.	
	NAT.	LP.
3/8	—	10
1/2	10	30
3/4	70	150
1	200	250
1 1/4	250	—

FOR GAS PRESSURES OF 0.5 PSIG OR LESS BASED ON A 0.60 AND 1.50 SPECIFIC GRAVITY GAS.

5. **TEST PIPING FOR LEAKS.** Before turning gas under pressure into piping, all openings from which gas can escape must be closed. Immediately after turning on gas, the system should be checked for leaks. This can be done by watching the ½ cubic foot test dial for 5 minutes to show any movement, or by soaping each pipe connection and watching for bubbles. If a leak is found, make the necessary repairs and repeat the above test.

**NOTE:** Defective pipes or fittings should be replaced and not repaired. Never use a flame or fire of any form to locate gas leaks, use a soap solution.

6. After the piping and meter have been checked completely, **PURGE THE SYSTEM OF AIR.** Do not bleed the air inside the unit. Be sure to relight all the gas pilots on other appliances.

**NOTE:** The Burner and its individual shutoff valve must be disconnected from the gas supply piping system during any pressure testing at excess of ½ psig.

# VENTING INSTRUCTIONS

1. The Model BMJ-350-I must be provided with an exhaust ventilation system in accordance with the National Fire Protection Association Standard For Removal of Smoke and Grease Laden Vapors From Commercial Equipment, NFPA 96. Minimum vent hood size should be at least 6 ft. by 5 ft. with a minimum overhang above meat loading doors of 15 inches. The lower edge of the vent hood should be located a minimum of 6 ft. 10 inches from the floor.
2. Unit must be level for proper grease drainage.
3. It is recommended that the unit be supplied with a return air system to eliminate negative air pressure in the room or building. Return air **MUST** be equal to or in excess of the exhausted air.
4. **MINIMUM SPACINGS TO COMBUSTIBLE MATERIALS:**
  - Back - 2 inches
  - Right Side - 18 inches (Access for Service)
  - Left Side - 2 inches
  - Top - 18 inches
  - Front - 48 inches (Access for loading and unloading)
  - Floor - May be combustible material.**NOTE:** For flush mount, use BBR Insulation Kit #2097.

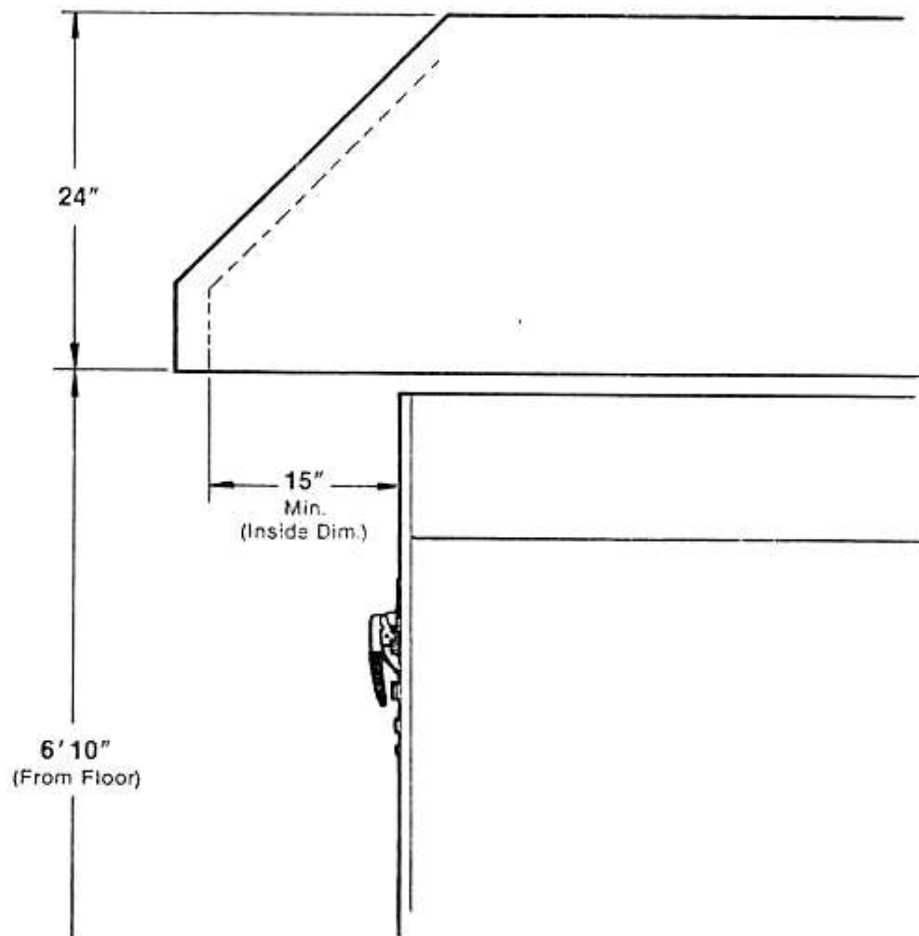

5. The volume of air exhausted should be of a sufficient level to provide the capture and removal of smoke and cooking vapors. The air velocity through the duct shall not be less than 1500 ft/min and shall not exceed 2500 ft/min.

## VENTING DIAGRAM

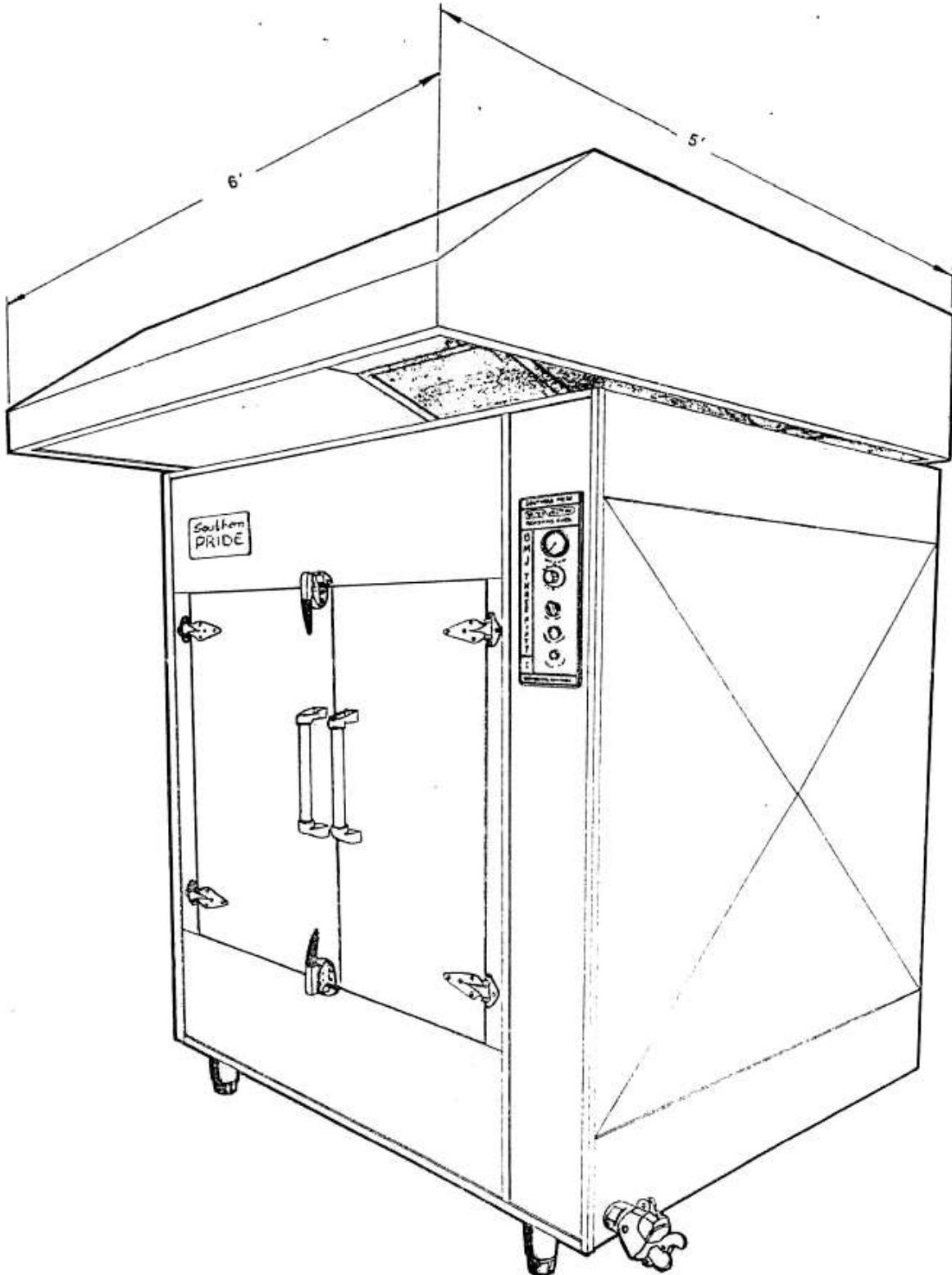

# BMJ-350-I WIRING

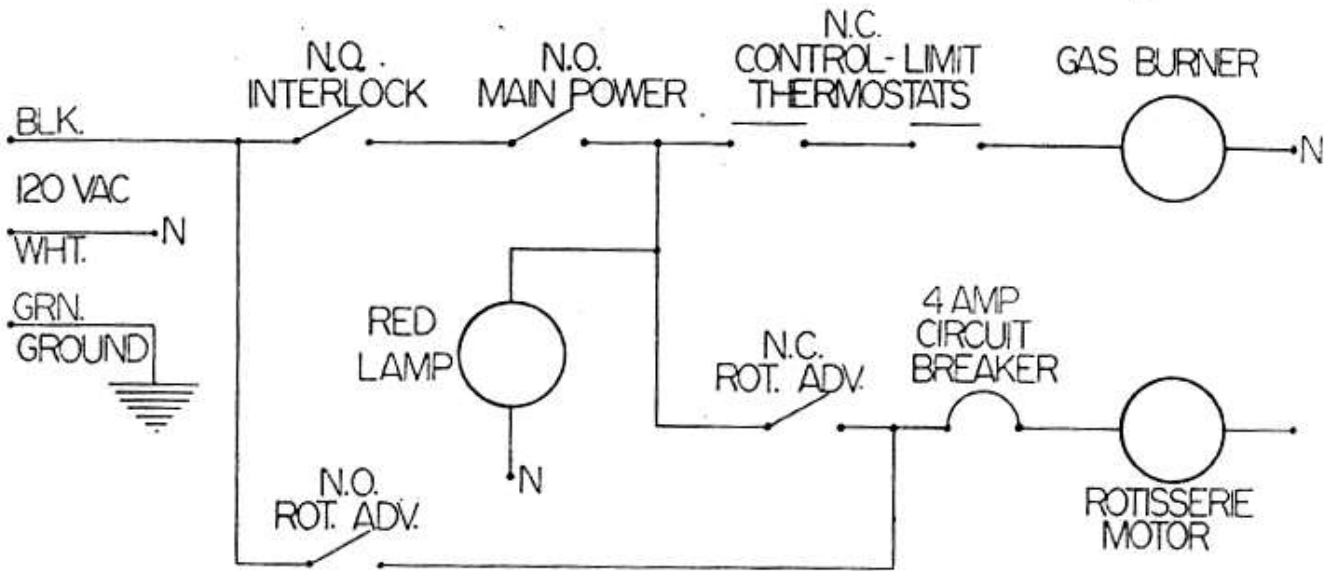

WIRING SCHEMATIC

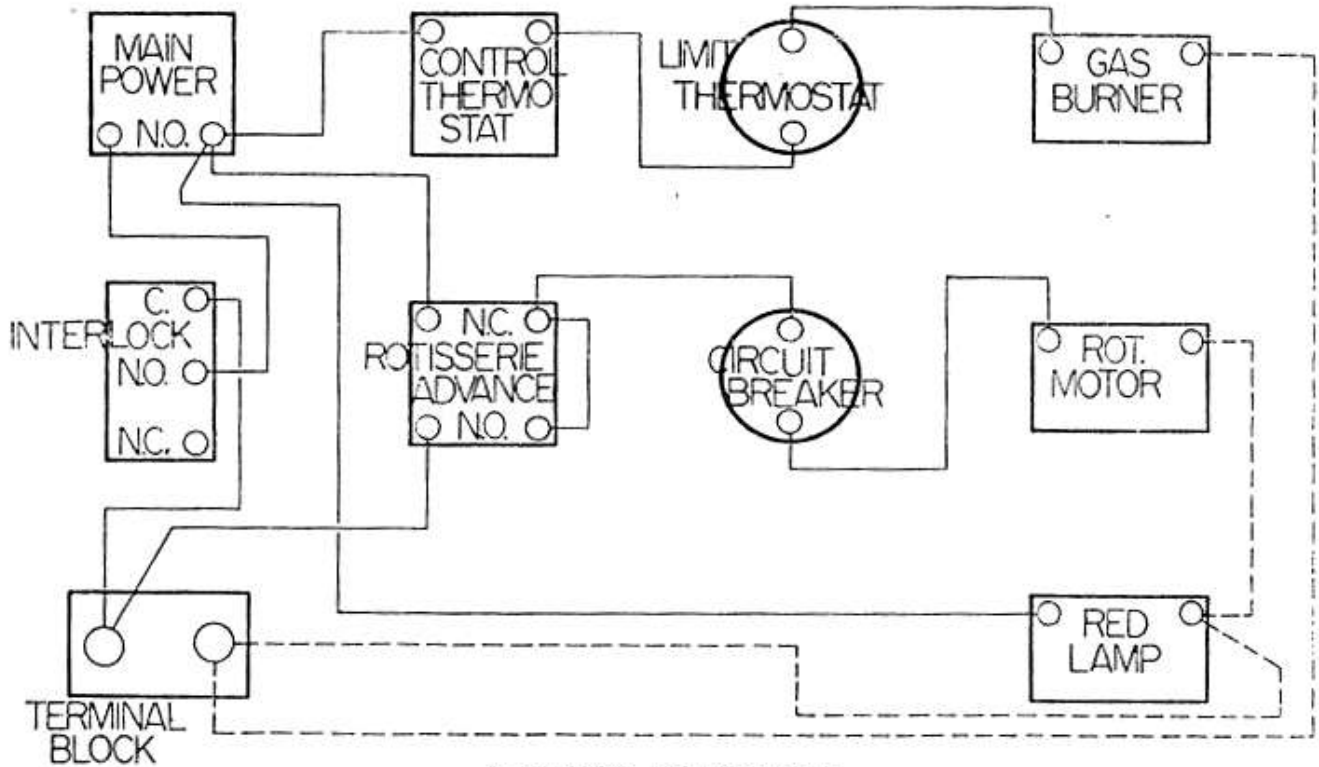

WIRING DIAGRAM



# BMJ-350-ISE WIRING

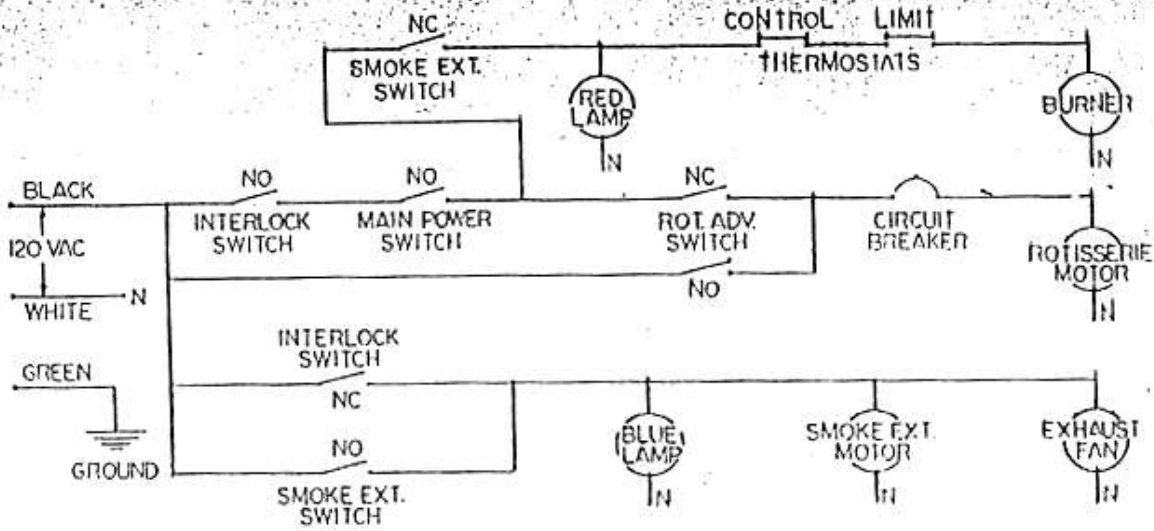

WIRING SCHEMATIC

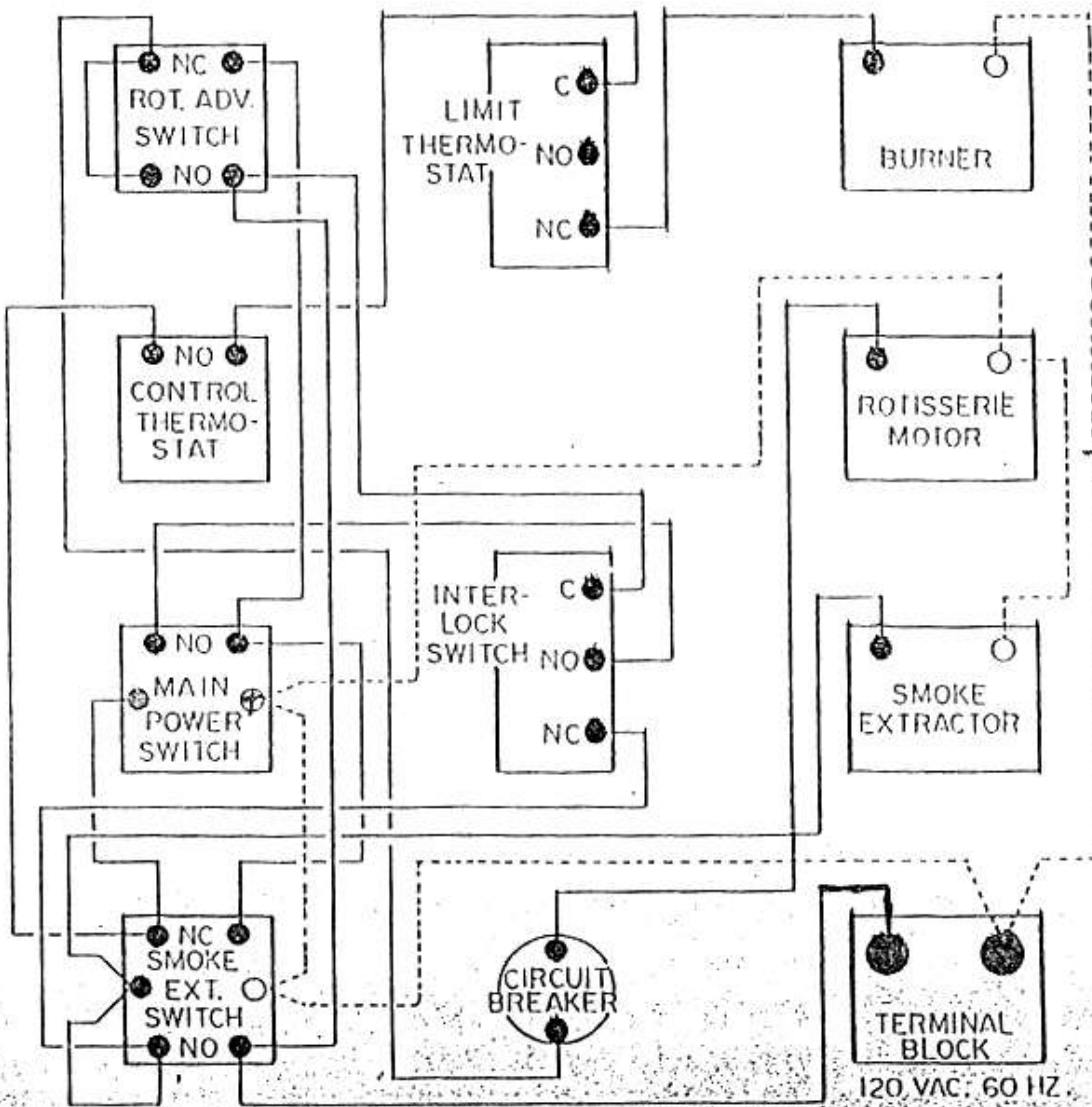

WIRING DIAGRAM

## LIMITED WARRANTY

B. B. Robertson Company guarantees all new equipment of its manufacture to be free of defects in material and factory workmanship for a period of one year provided that the equipment is installed in the Continental United States and Hawaii and operated according to the Owner's Manual while located at the original address of installation, the warranty registration card has been completed and returned to the factory within fifteen (15) days after installation and a start-up has been performed by an authorized service agent.

B. B. Robertson Companies obligation under this warranty is limited to one of the following options with the option applicable to be selected by B. B. Robertson at the sole discretion of B. B. Robertson.

1. Owner to return part freight PREPAID, B. B. Robertson to repair at own expense if defective and ship part back to owner freight collect.
2. B. B. Robertson to furnish replacement part freight collect without requesting return of the defective part.
3. B. B. Robertson to furnish replacement part freight collect in exchange for return of the defective part freight collect.

Under certain circumstances B. B. Robertson will reimburse owner for limited labor costs in replacing parts during a period of not more than thirty (30) days after installation, provided that work is prior authorized and confirmed by B. B. Robertson's Service Manager.

Because B. B. Robertson Companies does not and cannot control the owner's installation, use and maintenance of equipment manufactured by B. B. Robertson this warranty does not cover: any equipment calibrated after start-up and acceptance; any component disassembled in the field; damage due to improper cleaning, i.e. burner (hosing or "watering down" machines will cause electrical failures not covered by warranty); blown fuses and accessory components not installed or manufactured by B. B. Robertson. Shipping damage must be reported to the carrier and is not covered under this warranty.

B. B. Robertson Companies will not be liable for damage as a result of improper installation, misuse, abuse, alteration of original design, incorrect voltage, unauthorized service, or breakage of fragile items. B. B. Robertson Companies will not be liable for any loss or consequential damage or expense accruing directly or indirectly from the use of equipment covered by this warranty including any production or product losses or other damages which may occur as a result of equipment malfunction or failure. This warranty does not cover cooking performance, which is a function of food types, textures, temperatures and other variables chosen by the owner and over which B. B. Robertson has no control. The effect of corrosion, fire and normal wear on the equipment or component parts is not covered by this warranty. This warranty does not apply to damage caused by accident or to damage caused by the negligence of the owner and the employees of the owner or to damage caused by lightning generated electrical current or any other Act of God whatsoever. This warranty does not apply to any equipment bearing a serial number which has been tampered with or altered.

This warranty is exclusive and is in lieu of all other warranties, express or implied, including any implied warranty or merchantability or fitness for a particular purpose, each of which is hereby expressly disclaimed, the remedies described above are exclusive and in no event shall B. B. Robertson Company be liable for special, consequential or incidental damages for the breach or delay in performance of warranty.

**B. B. ROBERTSON COMPANY**  
618-997-9348

Route 2, Box 21A

Marion, Illinois 62959  
1-800-851-8180

# MODEL BMJ-350-I REPLACEMENT PARTS LIST

PART NUMBER	DESCRIPTION
304	FGG Extra High Temp. Food Machinery Grease (Dubois)
322	Synthetic Worm Gear Oil (Mobil SHC 634)
1003	Control Thermostat (100-325°F)
1038	Limit Thermostat (340°F)
1041	Gas Burner (Wayne P250 AF-EP)
1042	Interlock Switch
1068	4 Amp Circuit Breaker
1078	Rotisserie Motor (1/8 H.P.)
1080	Main Power Switch
1082	Rotisserie Advance Switch
1252	Flange Bearing
1255	Food Rack
1295	Ash Scoop
1296	Firebox Door Opener
2017	Gate Valve
2116	Door Hinge
<del>2428</del> 7012	Food Rack Hanger Assembly
2431	Rotisserie Reducer Gearbox (1800:1)
2433	Teflon Axle Seal
3020	Door Latch
3026	Meat Door Gasket (left)
3027	Meat Door Gasket (right)

## GAS BURNER REPLACEMENT PARTS (Wayne P250 Af-EP)

1064	Gas Valve W/Control (Natural Gas)
1065	Pilot Burner Assembly W/Electrode & Ignition Cable (Natural Gas)
1069	24 Volt Transformer
1070	Motor Switching Relay
1084	Gas Valve W/Control (L.P. Gas)
1085	Pilot Burner Assembly W/Electrode and Ignition Cable (L.P. Gas)
1087	Burner Control Module (Honeywell 586G)
3019	Burner Conversion Kit (Natural Gas)
3029	Burner Conversion Kit (L.P. Gas)

## ACCESSORIES

1294	Ash Tote
DP-100	Drain Pan W/Screen and 10 Ft. of Hose